

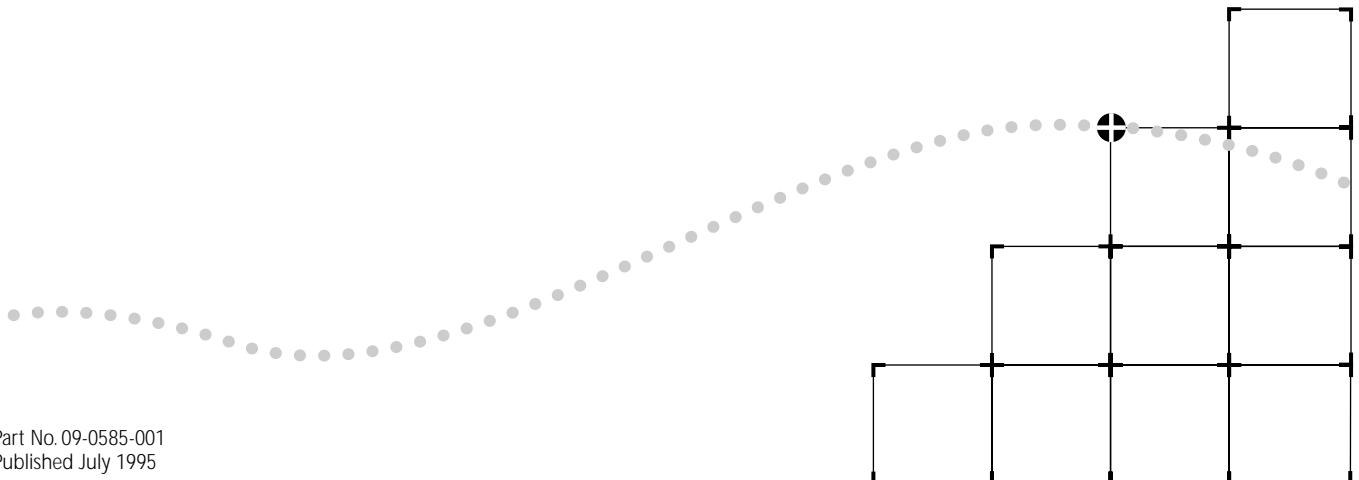

# NETBUILDER II<sup>®</sup> MP ETHERNET 6-PORT 10BASE-T AND 10BASE-FL MODULE INSTALLATION GUIDE

Members of the NETBuilder<sup>®</sup> Family



3Com Corporation ■ 5400 Bayfront Plaza ■ Santa Clara, California ■ 95052-8154

© 3Com Corporation, 1995. All rights reserved. No part of this documentation may be reproduced in any form or by any means or used to make any derivative work (such as translation, transformation, or adaptation) without permission from 3Com Corporation.

3Com Corporation reserves the right to revise this documentation and to make changes in content from time to time without obligation on the part of 3Com Corporation to provide notification of such revision or change.

3Com Corporation provides this documentation without warranty of any kind, either implied or expressed, including, but not limited to, the implied warranties of merchantability and fitness for a particular purpose. 3Com may make improvements or changes in the product(s) and/or the program(s) described in this documentation at any time.

**UNITED STATES GOVERNMENT LEGENDS:**

If you are a United States government agency, then this documentation and the software described herein are provided to you subject to the following restricted rights:

**For units of the Department of Defense:**

*Restricted Rights Legend:* Use, duplication or disclosure by the Government is subject to restrictions as set forth in subparagraph (c) (1) (ii) for restricted Rights in Technical Data and Computer Software clause at 48 C.F.R. 52.227-7013. 3Com Corporation, 5400 Bayfront Plaza, Santa Clara, California 95052-8145.

**For civilian agencies:**

*Restricted Rights Legend:* Use, reproduction or disclosure is subject to restrictions set forth in subparagraph (a) through (d) of the Commercial Computer Software - Restricted Rights Clause at 48 C.F.R. 52.227-19 and the limitations set forth in 3Com Corporation's standard commercial agreement for the software. Unpublished rights reserved under the copyright laws of the United States.

3ComFacts, Ask3Com, CardFacts, and NetFacts are service marks of 3Com Corporation.

3Com, NETBuilder, and NETBuilder II are registered trademarks of 3Com Corporation. 3Com Laser Library is a trademark of 3Com Corporation.

CompuServe is a registered trademark of CompuServe, Inc.

3Com registered trademarks are registered in the United States, and may or may not be registered in other countries.

Other brand and product names may be registered trademarks or trademarks of their respective holders.

Guide written, illustrated and produced by Debra Knodel, and edited by Pat Vaughn.

Printed on recycled paper.

# ABOUT THIS GUIDE

---

## Introduction

This guide describes how to install, cable, troubleshoot, and replace the NETBuilder MPEthernet 6-port 10BASE-T and 10BASE-FL modules (referred to as the 10BASE-T and 10BASE-FL modules throughout this guide) for the NETBuilder II® system. The information applies to all NETBuilder II chassis.

For more information about the NETBuilder II base system installation, refer to the *NETBuilder II Base System Installation Guide*.

This guide is intended for the system administrator, network equipment installer, or network manager who is responsible for installing and managing the network hardware. It assumes a working knowledge of network operations, but it does not assume prior knowledge of 3Com® internetworking equipment.



*If the information in the release notes shipped with your product differs from the information in this guide, follow the release notes.*

---

## Conventions

Table 1 and Table 2 list conventions that are used throughout this guide.

**Table 1** Text Conventions

Convention	Description
"Enter" vs. "Type"	When the word "enter" is used in this guide, it means type something, then press the Return or Enter key. Do not press the Return or Enter key when an instruction simply says "type."
"Syntax" vs. "Command"	When the word "syntax" is used in this guide, it indicates that the general form of a command syntax is provided. You must evaluate the syntax and supply the appropriate port, path, value, address, or string; for example:  Enable RIPIP by using the following syntax:  <code>SETDefault !&lt;port&gt; -RIPIP CONTrol = Listen</code>  In this example, you must supply a port number for !<port>.  When the word "command" is used in this guide, it indicates that all variables in the command have been supplied and you can enter the command as shown in text; for example:  Remove the IP address by entering the following command:  <code>SETDefault !0 -IP NETaddr = 0.0.0.0</code>





*For consistency and clarity, the full form syntax (upper- and lowercase letters) is provided. However, you can enter the abbreviated form of a command by typing only the uppercase portion and supplying the appropriate port, path, address, value, and so forth. You can enter the command in either upper- or lowercase letters at the prompt.*

**Table 1** Text Conventions (continued)

Convention	Description
Text represented as screen display	<code>This typeface</code> is used to represent displays that appear on your terminal screen, for example: <code>NetLogin:</code>
Text represented as commands	<b>This typeface</b> is used to represent commands that you enter, for example: <b><code>SETDefault !0 -IP NETaddr = 0.0.0.0</code></b>
Keys	When specific keys are referred to in the text, they are called out by their labels, such as “the Return key” or “the Escape key,” or they may be shown as [Return] or [Esc].  If two or more keys are to be pressed simultaneously, the keys are linked with a plus sign (+), for example:  Press [Ctrl]+[Alt]+[Del].
<i>Italics</i>	<i>Italics</i> are used to denote <i>new terms</i> or <i>emphasis</i> .

**Table 2** Notice Icons

Icon	Type	Description
	Information Note	Information notes call attention to important features or instructions.
	Caution	Cautions alert you to personal safety risk, system damage, or loss of data.
	Warning	Warnings alert you to the risk of severe personal injury.

# 1

## INSTALLATION

This chapter describes how to install the MP Ethernet 6-Port 10BASE-T or 10BASE-FL Module in your NETBuilder II® system. For clarity, these modules will be referred to as the 10BASE-T module and the 10BASE-FL module, or extended-format modules, throughout this guide. The front panels of both modules are shown below.

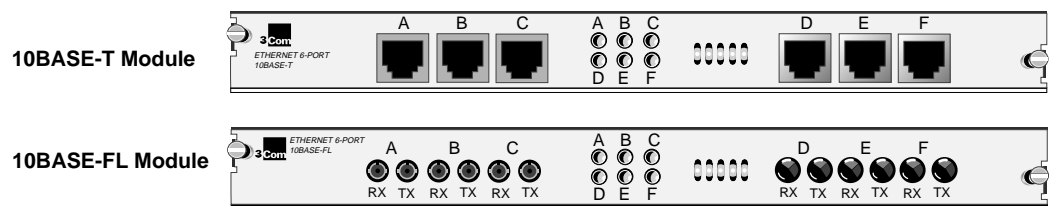

The 10BASE-FL module is shipped with plastic protective caps over each connector on the back panel. To keep the connectors clean, remove the caps only from the connectors you plan to use.



*You **must** have NETBuilder® software version 8.0 or later to install a 10BASE-T module, and NETBuilder software version 8.2 or later to install a 10BASE-FL module.*

### Before Installing the Module

Before you install a module in your NETBuilder II base system, follow these steps:

#### 1 Observe appropriate electrostatic discharge (ESD) precautions.

ESD can damage circuit board components. Failures resulting from ESD may not be covered under your warranty. To prevent ESD damage, follow these procedures:

- Keep the module in the antistatic shielded bag until you are ready to install it.
- Do not touch pins, leads, or solder connections on the board.
- Handle the board by the edges only.
- Store or ship the module in static-protective packaging.

Observe proper grounding techniques when handling the module: Use a foot strap and grounded mat, or wear a grounded static discharge wrist strap.

#### 2 Inspect the module for shipping damage.

If you find any damage, file a report with the shipping company. If the module must be returned to your network supplier, ship it in the original shipping carton or in a carton that provides equivalent protection.

- 3 The following figure shows the locations of the serial number and MAC address on the component side of the module.



*The 10BASE-T and the 10BASE-FL modules have IEEE network addresses and not MAC addresses as stated throughout this guide. The term “MAC address” is used by the software to indicate both MAC and IEEE network addresses.*

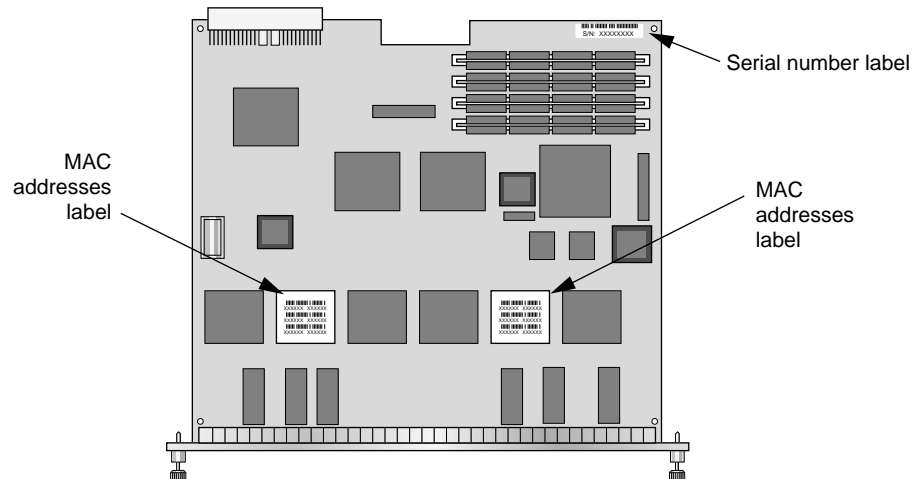

**Serial number example:** 1DD 01234 for 10BASE-T  
1DX 01234 for 10BASE-FL

**MAC addresses example:** 0800021A4B51, 0800021A4B52, 0800021A4B53

Write your module addresses down in the space provided below or in a place where you can find them for future reference. You will need this information if you have to contact your network supplier.

Serial Number:

MAC Addresses:

---



---



---



---



---



---

The MAC addresses are also encoded in the module's EEPROM. Use the procedure in Chapter 1 of the *NETBuilder II Base Installation Guide* to display the MAC addresses encoded in the EEPROM.

## Installing the Module

The following sections show how to install a 10BASE-T or a 10BASE-FL module in all NETBuilder II base systems.

In all chassis models, you can safely install a module without turning off the power or rebooting the NETBuilder II system. You will need a small flatblade screwdriver.

**4- and 8-Slot Chassis** Use the following procedure to install your module in a 4-Slot or 8-Slot chassis:

- 1 Remove the cable strain relief bracket from the chassis if it is installed.
- 2 You must install your first module in the two adjacent slots immediately below the CEC module. If you are installing two or more modules, you must install them in descending order from the top pair of I/O slots.

If you plan to install your module in the bottom slots you may need a field upgrade kit. See "Extended-format Modules in Older NETBuilder Chassis."

- 3 Remove the blanking plates. Remove the screw that secures the center divider between the two slots that you selected and remove the center divider.

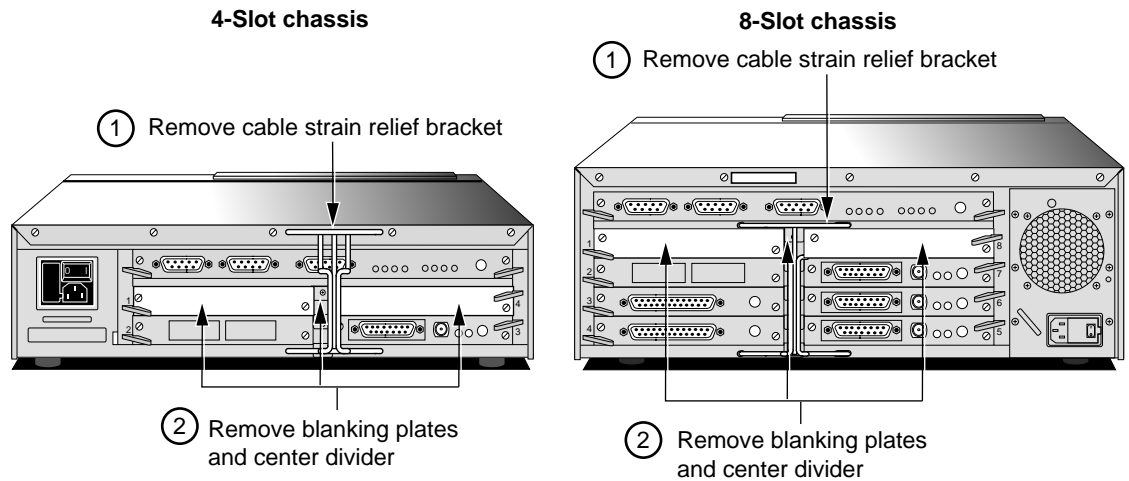

**CAUTION:** Remove the blanking plates only from the slots where you plan to install the module. All unused I/O slots require blanking plates for proper cooling and regulatory compliance. Failure to cover open slots can result in overheating of the unit which will void the warranty.

- 4 Insert the module in the uncovered I/O slot as shown in the following illustration. (Although a 10BASE-T is pictured, the steps apply to either module.)

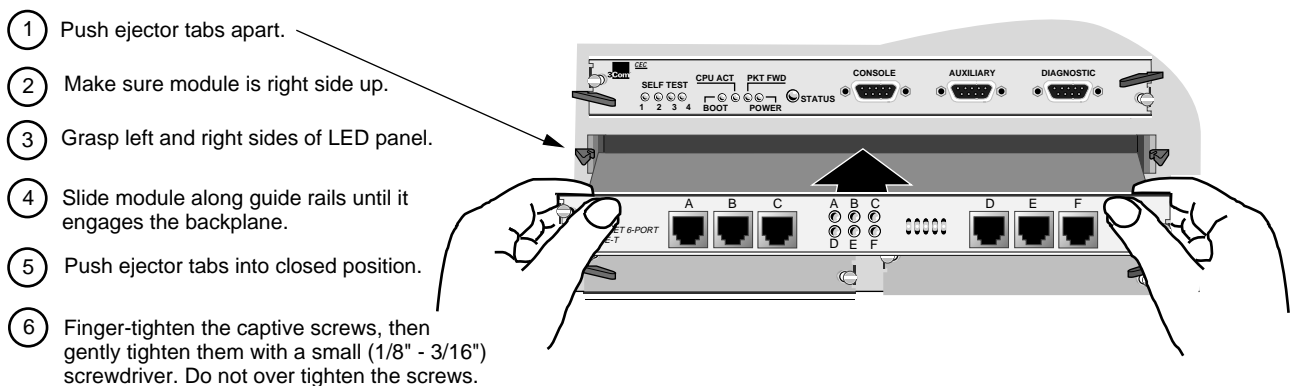

- 5 Attach up to six RJ-45 cables to a 10BASE-T module or up to six fiber-optic cables to a 10BASE-FL module.

- 6 Replace the cable strain relief bracket if necessary.

Route the cables through the cable strain relief bracket.

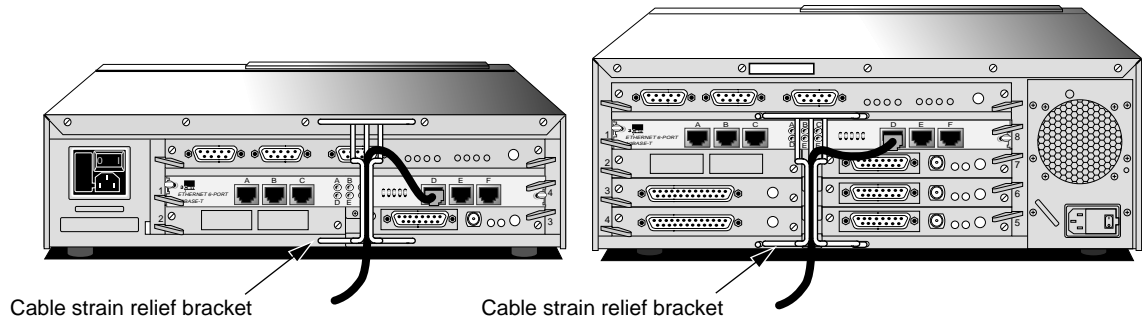

### Extended-format Modules in Older NETBuilder Chassis

Some older 4-Slot and 8-Slot chassis are unable to accommodate extended-format modules. If your chassis does not have a removable center divider between I/O slots, you will not be able to install these modules. If your chassis does have a removable center divider but is still an older model, you may need a field upgrade kit if you plan to install your module in the bottom slots, in order to maintain Class B/CESPERB compliance.

### Field Upgrade Kit for Older Chassis

When installing extended-format modules into slots 2 and 3 in older 4-Slot chassis and slots 4 and 5 in older 8-Slot chassis, EMI spring clips must be installed to ensure continued compliance with emissions requirements. Contact your 3Com service organization to obtain spring clips and installation instructions (or field upgrade kit). The following illustration identifies the chassis configuration that requires the use of the field upgrade kit. This illustration applies to the 4-Slot and the 8-Slot chassis, although only the 4-Slot chassis is shown.

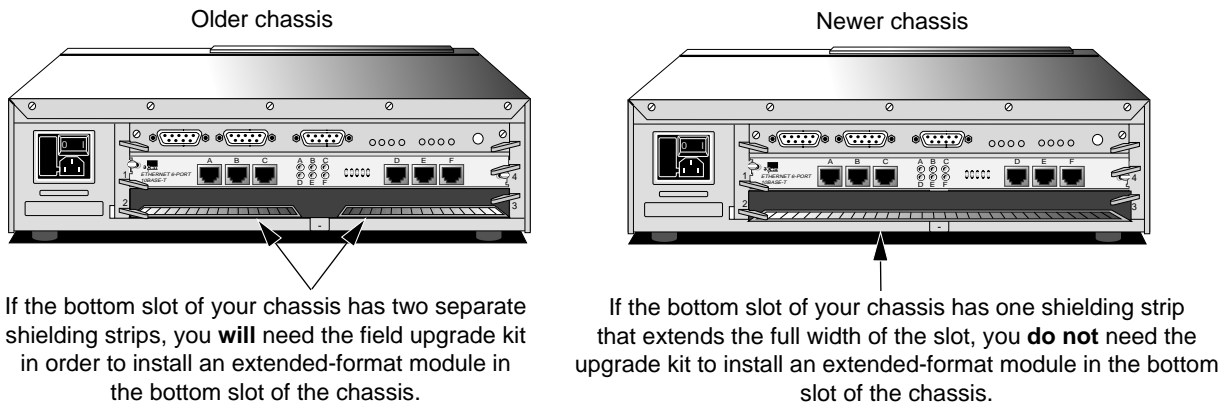

If the bottom slot of your chassis has two separate shielding strips, you **will** need the field upgrade kit in order to install an extended-format module in the bottom slot of the chassis.

If the bottom slot of your chassis has one shielding strip that extends the full width of the slot, you **do not** need the upgrade kit to install an extended-format module in the bottom slot of the chassis.

**Extended Chassis** Use the following procedure to install your extended-format module in an Extended chassis.

- 1 Select the slot you plan to use for the module (except for the two left-most slots) and remove the card carrier blanking plate from that slot.

It is not necessary to remove the cable strain relief brackets if they are installed.



**CAUTION:** Remove only the blanking plates from the slots where you plan to install a module. All unused I/O slots require blanking plates for proper cooling and regulatory compliance. Failure to cover open slots can result in overheating of the unit, which will void the warranty.

- 2 Insert the module in the selected slot using the steps shown in the illustration. (Although a 10BASE-T module is pictured, these steps apply to either module).

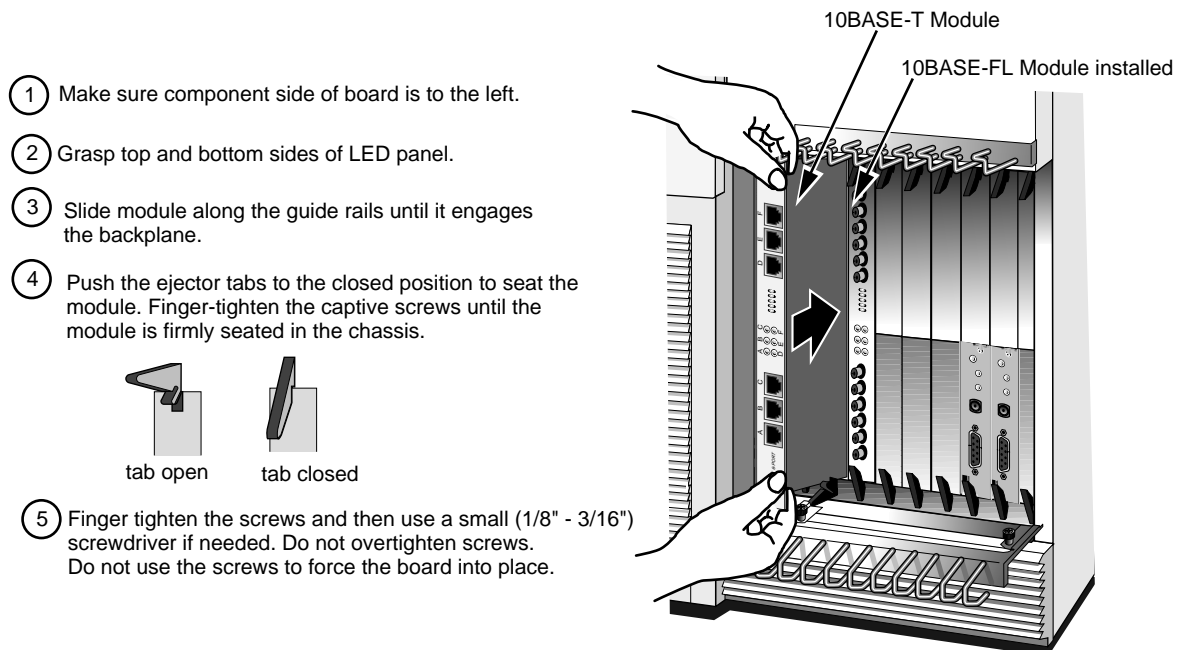

- 3 Attach up to six RJ-45 or fiber-optic cables to the module.
- 4 Route the cables through the strain relief bracket as shown:

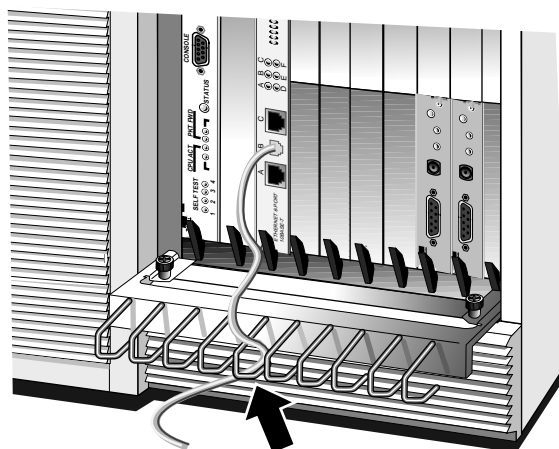

## Cabling the Module

Table 1-1 lists cable types, multistation access units (MAUs) and emissions classes compatible with the 10BASE-FL Module.



*For the 10BASE-T module, FCC A and VCCI, Class A unshielded category III cable may be used. For VDE B, shielded category III cable is required. Shield should be terminated 360 degrees at plug.*

*All compliance testing was accomplished using Stewart Stamping, part number 940 SP-36-08-08.*

**Table 1-1** Cable Types, Multistation Access Units, and Emissions Compliance

Cable Type		Emissions Compliance*	
		FCC Class A VCCI Class A	EN55022 Class B VDE Class B
UTP†	<b>100 ohm</b>		
	Category 3	yes	no
	Category 4	yes	no
	Category 5	yes	no
Shielded UTP	<b>100 ohm</b>		
	Category 3	yes	yes
	Category 4	yes	yes
	Category 5	yes	yes

\* Shielding of all cable types should be terminated 360 degrees at the cable plug.

† All UTP compliance testing was accomplished using cables built with Stewart Connector Co. connector, part number 940 SP-36-08-08.

# 2

## OVERVIEW

This chapter describes 10BASE-T and 10BASE-FL module features and specifications.

### Module Features

Table 2-1 summarizes the 10BASE-T and 10BASE-FL module features.

**Table 2-1** 10BASE-T and 10BASE-FL Module Features

Feature	Summary	10BASE-T Module	10BASE-FL Module
Compatibility	Fully compatible with all other NETBuilder II modules.	✓	✓
Processing capability	Off-loads filtering and forwarding tasks from the CEC.	✓	✓
Six RJ-45 ports	High port density, up to 48 ports in the extended chassis.	✓	✓
Hot-swap capability	Allows you to install and remove the module without turning off the NETBuilder II system.	✓	✓
Cable support	Supports RJ-45. Supports fiber optic.	✓	✓
Line speeds*	Up to and beyond 500,000 packets per second.	✓	✓
Self-test and diagnostic capability	Monitors network and signals status through the LED and the LED bar graph.	✓	✓
Accessible EEPROM information	Provides module product information that can be accessed through the monitor utility.	✓	✓

\* Line speeds are selected through software. Refer to the software manuals for more information.

### Specifications

This section describes 10BASE-T and 10BASE-FL module components and specifications.

#### LEDs and LED Bar Graph

Both modules have six tricolor LEDs, one for each port, and an LED bar graph display. The following figure shows the location of the LEDs on each module. Table 2-2 describes the states of the per-port tricolor LEDs.

The bar graph LED display has four green LEDs that indicate gradations of module traffic. The yellow LED lights when the module can no longer process any more traffic.

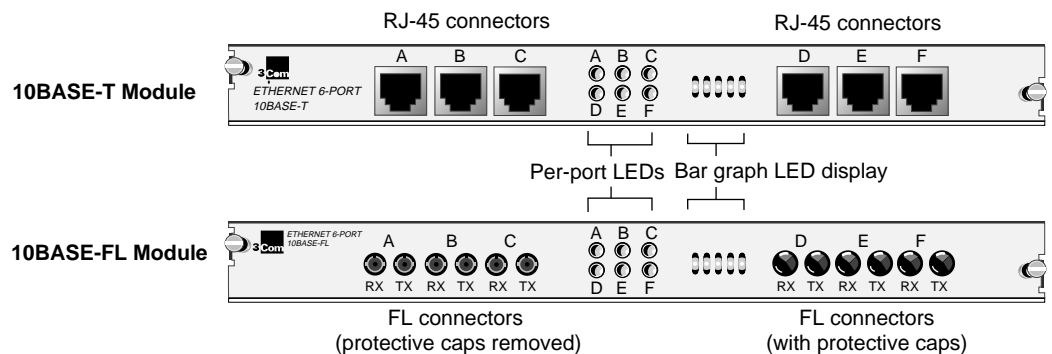

**Table 2-2** Per-Port Tricolor LED States

Condition	Indicates
Off	Module is not functioning; for example, there is no power to the system or the wrong system software is installed.
Red	Reset, error condition, broken fiber-optic link, or self-test failure (red light appears to be blinking when self-test fails as system intermittently checks the status).
Yellow	Module is in self-test mode or port/path has been disabled.
Green	Module is functioning normally.
Red/Green	LEDs alternately flash red and green. Module is functioning, but connections are disabled; for example, a cable is not installed or is not connected properly.

## Connectors

Table 2-3 describes the connectors for the both modules.

**Table 2-3** 10BASE-T and 10BASE-FL Module Connectors

Location	Connector(s)	No. of Pins	Purpose
Backplane	J1 and J3	48-pin	Connects module to the core bus.
	J2	8-pin	Power connector.
Front panel (10BASE-T)	A– F (six RJ-45 twisted pair interfaces)		Allows Ethernet connections.
Front panel (10BASE-FL)	Six fiber-optic input and six fiber-optic output connectors		Allows fiber-optic connections.

## Physical Specifications

Table 2-4 and Table 2-5 list the physical description and maximum current consumption for both module types.

**Table 2-4** Physical Description

Attribute	Description
Length	9.3 in (22.3 cm)
Width	10.8 in (27.4 cm)
Height	0.6 in (1.5 cm)
Weight	1.2 lb (.544 kg)

**Table 2-5** Maximum Current Consumption

+5 Volts	+12 Volts	-12 Volts
6.0 amp	0.08 amps	0.04 amps

# 3

## TROUBLESHOOTING AND REPLACING MODULES

This chapter describes how to troubleshoot and replace 10BASE-T and 10BASE-FL modules. If your module fails to operate or you receive a self-test failure message at startup, you may have an inappropriate network connection, or an inoperative module.

### Troubleshooting

Table 3-1 describes common malfunctions with the 10BASE-T and 10BASE-FL modules, possible causes, and actions to take. If you cannot resolve a problem, contact your network supplier. Refer to Appendix A to find out who to contact in your area.

**Table 3-1** Troubleshooting the 10BASE-T and 10BASE-FL modules

Symptom	Cause and Action
The following message is displayed at startup:  Ethernet 6-port Interface: Self Tests failed - slot X  (The value of X can be 1 through 4 or 1 through 8, depending on which chassis you have.)	<i>Self-test failure</i>  Make sure the module is inserted completely into the chassis.  Make sure there are no bent pins on the backplane connector. If you still have a self-test failure, contact your network supplier.
If the board has a physical interface to another serial device and the following message is displayed:  Path 1 Available Path 1B Available Path 1C Available Path 1D Available Path 1E Available Path 1F Available	<i>Incomplete path</i>  Make sure the cable is securely attached.  If the cable is correctly attached and your paths are still not coming up, make sure there is a complete data path and correct clocking between both ends of the serial link. Check DSU/CSU and telco connections.
but the next message is <i>not</i> displayed:  Path 1 Up Path 1B Up Path 1C Up Path 1D Up Path 1E Up Path 1F Up	
The module's status LED is off when there is power to the system and other installed modules are operating.	<i>Disabled module</i>  The module may not be properly connected to the backplane. Remove and reinsert the module.  If it still fails to work, replace the module.

---

## Replacing the Module

If any component in the module fails, you will need to replace the entire module. Both the 10BASE-T and 10BASE-FL module can be hot-swapped, which means that you can safely remove and install a new one without turning off or rebooting the NETBuilder II system. You may need a small, flat-blade screwdriver.

Follow these steps to remove and replace a module in your 4-Slot, 8-Slot, or Extended chassis:



**WARNING:** *To perform the following steps on an 8-Slot Extended chassis or an 8-slot module with a dual power supply, you must be a trained, qualified technician.*

- 1 Disconnect any network cabling from the module, then remove the cable from the strain relief bracket or brackets. (You do not need to remove the brackets on the Extended chassis.)
- 2 Unscrew the two captive screws (use a screwdriver if necessary) that anchor the module in the slot until they disengage from the chassis. Do not remove the screws from the I/O panel.
- 3 Push the ejector tabs to the open position.  
The board will disengage from the backplane and partially eject from the slot.
- 4 Use both hands to grasp the board and gently pull it from the slot.
- 5 Install the new module using the procedures outlined in Chapter 1.

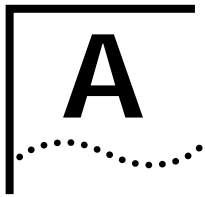

# TECHNICAL SUPPORT

3Com provides easy access to technical support information through a variety of services. This appendix describes these services.

---

## On-line Technical Services

3Com offers worldwide product support seven days a week, 24 hours a day, through the following on-line systems:

- 3Com Bulletin Board Service (3ComBBS)
- Ask3Com<sup>SM</sup> on CompuServe<sup>®</sup>
- 3ComFacts<sup>SM</sup> Automated Fax Service

## 3Com Bulletin Board Service

3ComBBS contains patches, software, and drivers for all 3Com products, as well as technical articles. This service is available via modem seven days a week, 24 hours a day. To reach the service, set your modem to 8 data bits, no parity, and 1 stop bit. Call the telephone number nearest you:

Country	Baud Rate	Telephone Number
Australia	up to 14400 baud	(61) (2) 955 2073
France	up to 14400 baud	(33) (1) 69 86 69 54
Germany	up to 9600 baud up to 9600 baud	(49) (89) 627 32 188 (49) (89) 627 32 189
Hong Kong	up to 9600 baud	(852) 537 5601
Italy (fee required)	up to 9600 baud	(39) (2) 273 00680
Japan	up to 14400 baud	(81) (3) 3243 9245
Singapore	up to 9600 baud	(65) 534 5693
Taiwan	up to 14400 baud	(886) (2) 577 6160
U.K.	up to 14400 baud	(44) (442) 278278
U.S.	up to 14400 baud	(1) (408) 980 8204

## Ask3Com on CompuServe

Ask3Com is a CompuServe-based service containing patches, software, drivers, and technical articles about all 3Com products, as well as an interactive forum for technical questions. To use Ask3Com, you need a CompuServe account.

To use Ask3Com:

- 1 Log on to CompuServe.
- 2 Enter **go threecom**
- 3 Press [Return] to see the Ask3Com main menu.

### 3ComFacts Automated Fax Service

3Com Corporation's interactive fax service, 3ComFacts, provides data sheets, technical articles, diagrams, and troubleshooting instructions on 3Com products 24 hours a day, seven days a week. Within this service, you may choose to access CardFacts<sup>SM</sup> for adapter information, or NetFacts<sup>SM</sup> for network system product information.

- **CardFacts** provides adapter installation diagrams, configuration drawings, troubleshooting instruction, and technical articles.

Document 9999 provides you with an index of adapter documents.

- **NetFacts** provides data sheets and technical articles on 3Com Corporation's hub, bridge, router, terminal server, and software products.

Document 8888 provides you with an index of system product documents.

Call 3ComFacts using your touch-tone telephone. International access numbers are:

**Table A-1**

Country	Fax Number
Hong Kong	(852) 537 5610
U.K.	(44) (442) 278279
U.S.	(1) (408) 727 7021

Local access numbers are available within the following countries:

**Table A-2**

Country	Fax Number	Country	Fax Number
Australia	800 123853	Italy	1678 99085
Denmark	800 17319	Netherlands	06 0228049
Finland	98 001 4444	Norway	05 01 1062
France	05 90 81 58	Sweden	020 792954
Germany	0130 8180 63	U.K.	0800 626403

### 3Com Documentation on CD-ROM

An extensive library of 3Com product documentation is available in CD-ROM format through Support On-Site for Networks subscription service. This multivendor CD-ROM service, offered by Computer Library<sup>TM</sup>, a division of Ziff Communication, contains technical information and documentation from major data networking hardware and software manufacturers. Stand-alone and concurrent user subscriptions are available. For more information, call Computer Library at the following numbers:

Country	Telephone Number	Fax Number
U.S. and Canada	(800) 827 7889, ext. 515	(212) 503 4487
Outside the U.S. and Canada	(212) 503 4400, ext. 515	(212) 503 4487

## Support from Your Network Supplier

If additional assistance is required, contact your network supplier. Many suppliers are authorized 3Com service partners who are qualified to provide a variety of services, including network planning, installation, hardware maintenance, application training, and support services.

When you contact your network supplier for assistance, have the following information ready:

- Diagnostic error messages
- A list of system hardware and software, including revision levels
- Details about recent configuration changes, if applicable

If you are unable to contact your network supplier, see the following section on how to contact 3Com.

## Support from 3Com

If you are unable to receive support from your network supplier, technical support contracts are available from 3Com.

In the U.S. and Canada, call **(800) 876-3266** for customer service.

If you are outside the U.S. and Canada, contact your local 3Com sales office to find your authorized service provider:

Country	Telephone Number	Country	Telephone Number
Australia (Sydney)	(61) (2) 959 3020	Mexico	(525) 531 0591
(Melbourne)	(61) (3) 653 9515	Netherlands	(31) (3) 402 55033
Belgium	(32) (2) 7164880	Singapore	(65) 538 9368
Brazil	(55) (11) 241 1571	South Africa	(27) (11) 803 7404
Canada	(905) 882 9964	Spain	(34) (1) 3831700
France	(33) (1) 69 86 68 00	Sweden	(46) (8) 632 91 00
Germany	(49) (89) 6 27 32 0	Taiwan	(886) (2) 577 4352
Hong Kong	(852) 868 9111	United Arab Emirates	(971) (4) 311303
Italy	(39) (2) 273 02041	U.K.	(44) (628) 897000
Japan	(81) (3) 3243 9234	U.S.	(1) (408) 492 1790

## Returning Products for Repair

A product sent directly to 3Com for repair must first be assigned a Return Materials Authorization (RMA) number. A product sent to 3Com without an RMA number will be returned to the sender unopened, at the sender's expense.

To obtain an RMA number, call or fax:

Country	Telephone Number	Fax Number
U.S. and Canada	(800) 876 3266, option 2	(408) 764 7120
Europe	(44) (442) 278000	(44) (442) 236824
Outside Europe, U.S. and Canada	(1) (408) 492 1790	(1) (408) 764 7290

## LIMITED WARRANTY

**HARDWARE:** 3Com warrants its hardware products to be free from defects in workmanship and materials, under normal use and service, for the following lengths of time from the date of purchase from 3Com or its Authorized Reseller:

Internetworking products	One year
Network adapters	Lifetime
Ethernet stackable hubs and Unmanaged Ethernet fixed port repeaters	Lifetime* (One year if not registered)
*Power supply and fans in these stackable hubs and unmanaged repeaters	One year
Other hardware products	One year
Spare parts and spares kits	90 days

If a product does not operate as warranted during the applicable warranty period, 3Com shall, at its option and expense, repair the defective product or part, deliver to Customer an equivalent product or part to replace the defective item, or refund to Customer the purchase price paid for the defective product. All products that are replaced will become the property of 3Com. Replacement products may be new or reconditioned. Any replaced or repaired product or part has a ninety (90) day warranty or the remainder of the initial warranty period, whichever is longer.

3Com shall not be responsible for any software, firmware, information, or memory data of Customer contained in, stored on, or integrated with any products returned to 3Com pursuant to any warranty.

**SOFTWARE:** 3Com warrants that the software programs licensed from it will perform in substantial conformance to the program specifications therefor for a period of ninety (90) days from the date of purchase from 3Com or its Authorized Reseller. 3Com warrants the magnetic media containing software against failure during the warranty period. No updates are provided. 3Com's sole obligation hereunder shall be (at 3Com's discretion) to refund the purchase price paid by Customer for any defective software products, or to replace any defective media with software which substantially conforms to 3Com's applicable published specifications. Customer assumes responsibility for the selection of the appropriate applications program and associated reference materials. 3Com makes no warranty that its software products will work in combination with any hardware or applications software products provided by third parties, that the operation of the software products will be uninterrupted or error free, or that all defects in the software products will be corrected. For any third party products listed in the 3Com software product documentation or specifications as being compatible, 3Com will make reasonable efforts to provide compatibility, except where the non-compatibility is caused by a "bug" or defect in the third party's product.

**STANDARD WARRANTY SERVICE:** Standard warranty service for hardware products may be obtained by delivering the defective product, accompanied by a copy of the dated proof of purchase, to 3Com's Corporate Service Center or to an Authorized 3Com Service Center during the applicable warranty period. Standard warranty service for software products may be obtained by telephoning 3Com's Corporate Service Center or an Authorized 3Com Service Center, within the warranty period. Products returned to 3Com's Corporate Service Center must be pre-authorized by 3Com with a Return Material Authorization (RMA) number marked on the outside of the package, and sent prepaid, insured, and packaged appropriately for safe shipment. The repaired or replaced item will be shipped to Customer, at 3Com's expense, not later than thirty (30) days after receipt by 3Com.

**WARRANTIES EXCLUSIVE:** IF A 3COM PRODUCT DOES NOT OPERATE AS WARRANTED ABOVE, CUSTOMER'S SOLE REMEDY SHALL BE REPAIR, REPLACEMENT, OR REFUND OF THE PURCHASE PRICE PAID, AT 3COM'S OPTION. THE FOREGOING WARRANTIES AND REMEDIES ARE EXCLUSIVE AND ARE IN LIEU OF ALL OTHER WARRANTIES, EXPRESS OR IMPLIED, EITHER IN FACT OR BY OPERATION OF LAW, STATUTORY OR OTHERWISE, INCLUDING WARRANTIES OF MERCHANTABILITY AND FITNESS FOR A PARTICULAR PURPOSE. 3COM NEITHER ASSUMES NOR AUTHORIZES ANY OTHER PERSON TO ASSUME FOR IT ANY OTHER LIABILITY IN CONNECTION WITH THE SALE, INSTALLATION, MAINTENANCE OR USE OF ITS PRODUCTS.

3COM SHALL NOT BE LIABLE UNDER THIS WARRANTY IF ITS TESTING AND EXAMINATION DISCLOSE THAT THE ALLEGED DEFECT IN THE PRODUCT DOES NOT EXIST OR WAS CAUSED BY CUSTOMER'S OR ANY THIRD PERSON'S MISUSE, NEGLIGENCE, IMPROPER INSTALLATION OR TESTING, UNAUTHORIZED ATTEMPTS TO REPAIR, OR ANY OTHER CAUSE BEYOND THE RANGE OF THE INTENDED USE, OR BY ACCIDENT, FIRE, LIGHTNING, OR OTHER HAZARD.

**LIMITATION OF LIABILITY:** IN NO EVENT, WHETHER BASED IN CONTRACT OR TORT (INCLUDING NEGLIGENCE) SHALL 3COM BE LIABLE FOR INCIDENTAL, CONSEQUENTIAL, INDIRECT, SPECIAL, OR PUNITIVE DAMAGES OF ANY KIND, OR FOR LOSS OF REVENUE, LOSS OF BUSINESS, OR OTHER FINANCIAL LOSS ARISING OUT OF OR IN CONNECTION WITH THE SALE, INSTALLATION, MAINTENANCE, USE, PERFORMANCE, FAILURE, OR INTERRUPTION OF ITS PRODUCTS, EVEN IF 3COM OR ITS AUTHORIZED RESELLER HAS BEEN ADVISED OF THE POSSIBILITY OF SUCH DAMAGES.

Some states do not allow the exclusion of implied warranties or the limitation of incidental or consequential damages for consumer products, so the above limitations and exclusions may not apply to you. This warranty gives you specific legal rights which may vary from state to state.

**GOVERNING LAW:** This Limited Warranty shall be governed by the laws of the state of California.

**3Com Corporation**  
5400 Bayfront Plaza  
Santa Clara, CA 95052-8145  
(408) 764-5000