



SuperStack® II PathBuilder® S330/S310

WAN Access Switches Reference Guide

Release 2.03

<http://www.3com.com/>

Part No. 010-11941-0004
Published December 1998

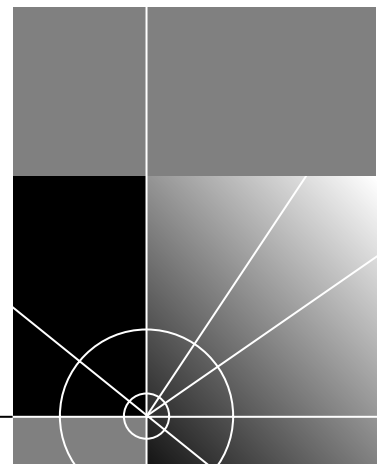

3Com Corporation
5400 Bayfront Plaza
Santa Clara, California
95052-8145

Copyright © 1998, 3Com Corporation. All rights reserved. No part of this documentation may be reproduced in any form or by any means or used to make any derivative work (such as translation, transformation, or adaptation) without written permission from 3Com Corporation.

3Com Corporation reserves the right to revise this documentation and to make changes in content from time to time without obligation on the part of 3Com Corporation to provide notification of such revision or change.

3Com Corporation provides this documentation without warranty, term, or condition of any kind, either implied or expressed, including, but not limited to, the implied warranties, terms or conditions of merchantability, satisfactory quality, and fitness for a particular purpose. 3Com may make improvements or changes in the product(s) and/or the program(s) described in this documentation at any time.

If there is any software on removable media described in this documentation, it is furnished under a license agreement included with the product as a separate document, in the hard copy documentation, or on the removable media in a directory file named LICENSE.TXT or !LICENSE.TXT. If you are unable to locate a copy, please contact 3Com and a copy will be provided to you.

UNITED STATES GOVERNMENT LEGEND

If you are a United States government agency, then this documentation and the software described herein are provided to you subject to the following:

All technical data and computer software are commercial in nature and developed solely at private expense. Software is delivered as "Commercial Computer Software" as defined in DFARS 252.227-7014 (June 1995) or as a "commercial item" as defined in FAR 2.101(a) and as such is provided with only such rights as are provided in 3Com's standard commercial license for the Software. Technical data is provided with limited rights only as provided in DFAR 252.227-7015 (Nov 1995) or FAR 52.227-14 (June 1987), whichever is applicable. You agree not to remove or deface any portion of any legend provided on any licensed program or documentation contained in, or delivered to you in conjunction with, this User Guide.

3Com, the 3Com logo, PathBuilder, and SuperStack are registered trademarks of 3Com Corporation. 3ComFacts is a service mark of 3Com Corporation.

All other company and product names may be trademarks of the respective companies with which they are associated.

CONTENTS

WARNING INFORMATION

Servicing	ix
Rack Mounting	ix
Power and Power Cords	x
EMI	x
Safety Classification of Ports for Connection to Telecommunications Networks	x

SUPPLEMENTARY REGULATORY INFORMATION

FCC Part 68 Statement	xi
Canadian CS-03 Approval Information	xi
CE Notice	xii

ABOUT THIS GUIDE

Introduction	1
How to Use This Guide	1
Conventions	2
Related Documentation	2

1 SYSTEM DESCRIPTION

PathBuilder S330 Features	3
PathBuilder S310 Features	5
Application Support	7
Key Benefits	7
Specifications	8
Options and Parts List	27

2 INSTALLATION

Installation Overview	30
Site Requirements	32
Installation Procedures	33
Step 1 (Optional): Install the Optional Modules in the Unit	33
Installing the Optional Modules in the Unit	35
Step 2: Install the Unit in the Rack	37
Step 3: Connect AC or DC Power and (optionally) the RPS System	38
Installing the Optional RPS System	39

Step 4: Connect I/O Cabling	40
Connecting to the T1/E1 UNI Interface	42
Connecting to the Serial Port	42
Connecting to the Ethernet Port	51
Connecting to the OC3/STM-1 Port	52
Connecting to the CBR Module	53
Connecting to the Voice Compression Module	55
Connecting to the DS3/E3 Module	56
Step 5: Connect the Management Terminal	57

3 GETTING STARTED

Using the Menu	61
Navigating through the Menu	61
Understanding the Menu Hierarchy	61
Using the Menu to Change Settings	62
Alarm Indicator	62
Performing Initial System Configuration	63
Configuring the System Clock	63
Setting up Communication Parameters	64
Configuring the Local Host IP Address	65
Configuring Trap Clients	67
Configuring the Default Gateway	68
Setting the Time and Date	69
Setting up Passwords	69
Performing Additional Super User Functions	71
Taking over a Read-Write Session	71
Erasing the System Database	71
Configuring In-band Management	72

4 CONFIGURING PATHBUILDER S330/S310 MODULES, PORTS, AND APPLICATIONS

Specifying General System Information	76
Viewing RS-232 Port Configuration Information	77
Viewing the Firmware Version	77
Downloading New Management Processor Firmware	78
Downloading via the Ethernet Port	79
Downloading via the Serial Port	79
Updating the Flash File System	80
Resetting the Interface Card	80
Viewing an Equipment List	80
Using the Configuration Management Menu	81
Using the List Card Menu	82
Configuring the Management CPU	82
Viewing MCPU Configuration Information	83
Configuring MCPU Shapers	83
Configuring the CTX	85
Configuring CTX Shapers	85

Configuring CTX Buffers	86
Setting Congestion Thresholds	88
Configuring Ports	88
Configuring the T1/E1 Interface	89
Configuring the T1/E1 Ports	89
Activation/Deactivation Bit Error Rates	91
Configuring UNI and IMA Groups	92
Adding UNI Groups	92
Adding IMA Groups	94
Viewing and Modifying IMA and UNI Groups	97
Deleting IMA and UNI Groups	97
Viewing IMA Link Status	98
Viewing IMA Group Status	100
Configuring the T1/ E1 Card	103
Configuring the OC3/STM-1 Port	104
Configuring the DS3/E3 UNI Module	105
Configuring the Serial Interface	106
Configuring the Serial Port	107
Configuring the Serial Card	110
Configuring the Ethernet Interface	110
Configuring the Ethernet Port	110
Configuring the Ethernet Card	111
Configuring the Bridge	112
Configuring Source Protocol Filtering	114
Configuring Source Address Filtering	116
Configuring Destination Address Filtering	118
Viewing the List Forwarding Table	119
Constructing the Bridge Static Table	120
Enabling and Disabling the Spanning Tree	121
Configuring the CBR Module	121
Configuring the CBR T1-DSX/E1 Port(s)	121
DS0 Trunk Conditioning	126
Configuring the CBR Serial Port	126
Configuring the CBR Card	128
Configuring the Voice Compression Module	129
Configuring VCM DS0 Channels	129
Configuring the VCM T1/E1 Port	130
Configuring the VCM Card	133
Configuring Virtual Circuits	133
Supported Classes of Virtual Circuits	134
Adding Virtual Circuits	134
Adding PVC Virtual Circuits	136
Configuring CBR Circuits for DBA	139
Defining RS366 (Video) Virtual Circuit Templates	141
Adding Voice Compression Module VCC Circuits	145
Adding VCM Subchannel Circuits	147
VCM Subchannel Virtual Circuit Example	149

Virtual Circuit Parameters	151
Common Virtual Circuit Parameters	151
MCPU Virtual Circuit Parameters	151
T1/E1 UNI Port Virtual Circuit Parameters	151
OC3/STM-1 Port Virtual Circuit Parameters	151
Serial Port Virtual Circuit Parameters	151
Ethernet Port Virtual Circuit Parameters	154
CBR Module Virtual Circuit Parameters	154
Voice Compression Module Virtual Circuit Parameters	156
VC and VP Address Translation	156
Viewing Existing Virtual Circuits	156
Viewing Virtual Circuits for the Entire Chassis	156
Viewing Virtual Circuits by Port or Group	158
Modifying Existing Virtual Circuits	159
Deleting Virtual Circuits	160
Managing the Video Dial Feature	160
Managing Video Dial-up Sessions	161
Starting Video Dial-up Sessions	161
Ending Video Dial-up Sessions	162
Viewing the Video Call Routing Table	162

5 PATHBUILDER S330 DIAGNOSTICS AND PERFORMANCE STATISTICS

Managing System Alarms	165
Viewing and Clearing Current Alarms	165
PathBuilder S330/S310 Alarm Messages	166
MCPU and CTX Module (System) Alarms	167
Alarms Common to Several Interfaces	169
DS1/E1 UNI Module Alarms	171
DSX-1/E1 CBR Module Alarms	176
SIM Alarms	177
Voice Compression Module Alarms	177
Working with History Alarms	178
Viewing and Printing History Alarms	178
Clearing History Alarms	178
Using Loopbacks	179
T1/E1 UNI Loopbacks	180
OC3/STM-1 Loopbacks	181
DS3 Loopbacks	181
E3 Loopbacks	182
CBR Loopbacks	182
Setting VCM Loopbacks	183
Setting VCM Port Loopbacks	183
Setting VCM Channel Loopbacks	183
Viewing Performance and ATM Statistics	185
Viewing Card Statistics	185

Viewing T1/E1 UNI Card Statistics	186
T1/E1 Port/Link Statistics	187
T1/E1 Group Statistics	188
Viewing OC3/STM-1 Card Statistics	189
Viewing OC3/STM-1 Performance Statistics	189
Viewing OC3/STM-1 ATM Statistics	191
Viewing DS3 Card Statistics	192
Viewing DS3 UNI Performance Statistics	192
Viewing DS3 UNI ATM Statistics	192
Viewing E3 Card Statistics	193
Viewing E3 UNI Performance Statistics	193
Viewing E3 UNI ATM Statistics	193
Viewing SIM Card Statistics	193
SIM HDLC Statistics	194
SIM Frame Relay Statistics	194
SIM ATM VC Statistics	194
Viewing Ethernet Card Statistics	195
Ethernet Statistics	195
Spanning Tree Statistics	196
Viewing CBR Module Card Statistics	197
CBR Performance Monitoring Statistics	197
CBR ATM Statistics	198
Viewing Voice Compression Module Statistics	199
Voice Compression Module Performance Monitoring Statistics	199
Voice Compression Module VC Statistics	200
Voice Compression Module Port Activity Statistics	200
Viewing Virtual Circuit Statistics	200
Viewing Virtual Circuit Statistics by Circuit	201
Viewing Virtual Circuit Statistics by Port/Group	202
Viewing Virtual Circuit Statistics by Shaper	202
Viewing Virtual Circuit Statistics by Buffer (Queue)	204

A TECHNICAL SUPPORT

Online Technical Services	205
World Wide Web Site	205
3Com FTP Site	205
3Com Bulletin Board Service	206
Access by Analog Modem	206
Access by Digital Modem	206
3ComFacts Automated Fax Service	206
Support from Your Network Supplier	206
Support from 3Com	207
Returning Products for Repair	208

B PATHBUILDER S330/S310 MODULE AND APPLICATION OVERVIEW

Management CPU	209
CTX Switch	209
CTX Output Queues and Memory Partition	210
Setting up a Virtual Circuit	211
VPI and VCI Ranges	212
Early and Partial Packet Discard	212
T1/E1 UNI Interface	212
OC3/STM-1 Port	213
DS3/E3 UNI Modules	213
Serial Interface	214
Serial Interface Frame Protocol Modes	214
ATM DXI Mode	215
HDLC/SDLC Mode	219
Frame Relay Mode	219
Ethernet Interface	222
Bridge Operation	223
Filtering	223
Spanning Tree	224
Spanning Tree Operation	224
Spanning Tree Instances	225
Addressing	225
Segmentation	228
Reassembly	228
Typical Ethernet and Voice Application Configurations	228
CBR Module	231
Structured DS1	233
DS0 Signaling and Dynamic Bandwidth Allocation	234
Unstructured DS1	237
Structured versus Unstructured Summary	237
Video Conferencing	238
Point-to-Point Video Conferencing	238
Multi-point Video Conferencing	240
Voice Compression Module	241
Supported Voice Compression Features	242

INDEX

3COM CORPORATION LIMITED WARRANTY

WARNING INFORMATION

This section contains warning information for AC-powered systems.



CAUTION: Use of controls or adjustments of performance or procedures other than those specified herein may result in hazardous radiation exposure.



CAUTION: Danger of explosion if battery is incorrectly replaced. Replace the battery with only the same or equivalent type as that recommended by the manufacturer. Dispose of used batteries according to the manufacturer's instructions.

Servicing

Service of this unit is to be performed by qualified service personnel only.

Service of certain components and subassemblies in this equipment is accomplished by the replacement of Field Replaceable Units (FRUs). However, safety agency approval requires that the servicing of other subassemblies within this product be referred to 3Com's service personnel.

The trim enclosure and other mechanically secured plates serve as protection barriers from potential hazardous internal areas. No attempt should be made to troubleshoot internal components with these protective barriers removed without first disconnecting the equipment from main power.

Rack Mounting

This equipment is for use only in complete equipment where the acceptability of the combination is determined by the applicable safety agency in the country in which it is installed. This includes UL in the U.S.A., CSA in Canada, and TUV in Europe.



CAUTION: Do not block the ventilation openings on the top and bottom of the unit during installation. A minimum of 1 rack unit (1.75") space is required.

Rack configurations with certain combinations of 3Com equipment installed in racks with a height greater than 50" (127 cm) may require a counter-balance weight, a stabilizer bar, or anti-tip legs to ensure rack stability in accordance with safety agency regulations.



CAUTION: When attaching the rack-mount ears, you must use the factory-supplied screws. Using screws other than those supplied with the rack-mount ears voids your warranty and could damage the PCB.



Power and Power Cords

This equipment is not intended for use with IT power distribution systems whose line to line voltage exceeds 250 VAC RMS defined by EN 60950 as having no direct connection to earth. The PathBuilder S330/S310 will auto-configure for 115 VAC or 220-240 VAC.

NORTH AMERICAN APPLICATIONS: Use a UL Listed and CSA Certified Cord Set rated 6 amps, consisting of a minimum 18 AWG, Type SVT or SJT three conductor cord maximum of 15 feet in length, with a NEMA 5-15P plug.

INTERNATIONAL APPLICATIONS: The power supply cords used with this equipment should be harmonized with all local standards applicable in the country in which it is installed.

Safety agency compliance requires this unit to be connected to branch circuits with overcurrent protection $\leq 20A$ for North American applications and $\leq 10A$ for international applications.

The power supply cord must be disconnected when servicing all components or subsystems.

EMI

FCC - This equipment generates, uses, and can radiate radio frequency energy, and if not installed and used in accordance with the instruction manual, may cause interference to radio communications. It has been tested and found to comply with the limits for a Class A computing device pursuant with Part 15 of the FCC Rules, which are designed to provide reasonable protection against such interference when operated in a commercial environment. Operation of this equipment in a residential area is likely to cause interference, in which case the user at his own expense will be required to take whatever measures may be required to correct the interference. These tests were conducted with shielded communications cables with metal connector hoods; the use of unshielded cables may void this compliance.

Canada - This digital apparatus does not exceed the Class A limits for radio noise emissions from digital apparatus set out in the Radio Interference Regulations of the Canadian Department of Communications.

Europe - This is a Class A product. In a domestic environment this product may cause radio interference, in which case, the user may be required to take adequate measures.

Safety Classification of Ports for Connection to Telecommunications Networks

The following port types in the product range are classified according to the Harmonized Europeans Standard EN41003, subclause 4.1.3, as follows:

E1/E3 - TNV normally operating within SELV limits (TNV-1)

¹Telecommunications Network Voltage (EN60950, subclause 1.2.8.8)

²Safety Extra-Low Voltage (EN60950, subclause 1.2.8.5)

SUPPLEMENTARY REGULATORY INFORMATION

This section describes the compliance of the SuperStack® II PathBuilder® S330 and the SuperStack® II PathBuilder® S310 WAN access switches (PathBuilder S330/S310) with FCC, Industry Canada, and CE regulations.

FCC Part 68 Statement

This equipment complies with Part 68 of the Federal Communications Commission (FCC) rules. On the product is a label that contains the FCC registration number for this device. If requested, you must provide this information to the telephone company.

This equipment is designed to be connected to the telephone network or premises wiring using a compatible modular jack which is Part 68 compliant. See installation instructions for details.

If this device causes harm to the telephone network, the telephone company will notify you in advance that temporary discontinuance of service may be required. The telephone company may request that you disconnect the equipment until the problem is resolved.

The telephone company may make changes in its facilities, equipment, operations, or procedures that could affect the operation of this equipment. If this happens, the telephone company will provide advance notice in order for you to make necessary modifications to maintain uninterrupted service.

If you experience trouble with this equipment or for repair or warranty information, please follow the applicable procedures explained in the Technical Support section of this manual (Appendix A).

Canadian CS-03 Approval Information

The Industry Canada label identifies certified equipment. This certification means that the equipment meets certain telecommunications network protective, operational, and safety requirements. Industry Canada does not guarantee the equipment will operate to your satisfaction.

Before installing this equipment, you should ensure that it is permissible to be connected to the facilities of the local telecommunications company. You must also install the equipment using an acceptable method of connection. In some cases, the inside wiring associated with a single line individual service may be extended by means of a certified connector assembly. You should be aware that compliance with the above conditions may not prevent degradation of service in some situations.

Repairs to certified equipment should be made by an authorized Canadian maintenance facility designated by the supplier. Any repairs or alterations you make to this equipment, or equipment malfunctions, may give the telecommunications company cause to request that you disconnect the equipment.

CE Notice

Marking by the symbol CE indicates compliance of the equipment with the EMC, Telecom and Low Voltage directives of the European Community. Such marking is indicative that this equipment meets or exceeds the following technical standards.

EN55022 - Limits and methods of measurement of radio interference characteristics of information technology equipment.

EN50082-1 - Electromagnetic compatibility - generic immunity standard part 1: residential, commercial, and light industrial.

CTR 12 - Connection of 2 Mbit/s Unstructured Leased Lines.

CTR13 - Connection to 2 Mbit/s Structured Leased Lines.

EN 60950 - Safety of Information Technology Equipment including Electrical Business Equipment.

EN 41003 - Particular safety requirements for electrical equipment to be connected to Telecom networks.



WARNING: *This customer equipment is to be installed and maintained by service personnel as defined by AS/NZS 3260 clause 1.2.14.3. (service Personnel). Incorrect connection of connected equipment to the General Purpose Outlet could result in a hazardous situation.*



WARNING: *Safety requirements are not fulfilled unless the equipment is connected to a wall socket outlet with protective earth contact.*

ABOUT THIS GUIDE

About This Guide provides an overview of this guide, tells you where to look for specific information, and describes guide conventions.

Introduction

This guide describes how to install and configure the SuperStack® II PathBuilder® S330 and SuperStack® II PathBuilder® S310 WAN access switches (PathBuilder S330/S310). It is intended for network administrators, system engineers, field engineers, and other personnel responsible for installing, configuring, and managing PathBuilder products.



If the information in the Release Notes shipped with your product differs from the information in this guide, follow the Release Notes.

Most user guides and release notes are available in Adobe Acrobat Reader Portable Document Format (PDF) or HTML on the 3Com World Wide Web site:

<http://www.3com.com/>

How to Use This Guide

Table 1 shows where to find specific information in this guide.

Table 1 Where to Find Specific Information

If you are looking for...	Turn to...
Descriptions of the features and benefits of the PathBuilder S330/S310	Chapter 1
System specifications	Chapter 1
Lists of PathBuilder S330/S310 parts and options available for purchase	Chapter 1
Installation instructions	Chapter 2
Information on how to get started using the PathBuilder S330/S310	Chapter 3
Instructions for using the PathBuilder S330/S310 menus	Chapter 3
Instructions for configuring PathBuilder S330/S310 modules and ports	Chapter 4
Instructions for building virtual circuits	Chapter 4
Instructions for setting up video conference sessions	Chapter 4
Instructions for configuring the Voice Compression module	Chapter 4
Instructions for viewing and clearing alarms	Chapter 5
Lists of supported alarms	Chapter 5
Information about setting loopbacks and the types of loopbacks available	Chapter 5
Instructions for viewing performance statistics and information about the types of statistics available	Chapter 5
Technical support information	Appendix A
Reference information about the specific interfaces and applications you can use with the PathBuilder S330/S310	Appendix B

Conventions

Table 2 and Table 3 list conventions that are used throughout this guide.

Table 2 Notice Icons



Icon	Notice Type	Description
	Information note	Information that describes important features or instructions
	Caution	Information that alerts you to potential loss of data or potential damage to an application, system, or device
	Warning	Information that alerts you to potential personal injury

Table 3 Text Conventions

Convention	Description
Screen displays	This typeface represents information as it appears on the screen.
The words “enter” and “type”	When you see the word “enter” in this guide, you must type something, and then press the Return or Enter key. Do not press the Return or Enter key when an instruction simply says “type.”
[Key] names	Key names appear in text in one of two ways: <ul style="list-style-type: none"> Referred to by their labels, such as “the Return key” or “the Escape key” Written with brackets, such as [Return] or [Esc]. <p>If you must press two or more keys simultaneously, the key names are linked with a plus sign (+). Example:</p> <p>Press [Ctrl]+[Alt]+[Del].</p>
Menu commands and buttons	Menu commands or button names appear in italics. Example: <p>From the <i>Help</i> menu, select <i>Contents</i>.</p>
Words in <i>italicized</i> type	Italics emphasize a point or denote new terms at the place where they are defined in the text.
Words in bold-face type	Bold text denotes key features.

Related Documentation

In addition to this guide, the following documentation may help you use the PathBuilder S330/S310:

PathBuilder S330/S310 Release Notes—Provides configuration help and information about new features and any known limitations and issues found in the release.

PathBuilder Switch Manager User Guide—Describes how to use PathBuilder Switch Manager to configure and manage PathBuilder WAN switches. Using PathBuilder Switch Manager, you can configure shelf, device, and circuit information; use a loopback panel to diagnose port cards; view line and interface statistics; and perform administrative functions such as configuring trap destinations and setting SNMP community strings.

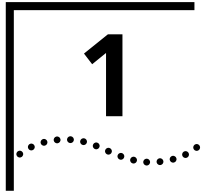

SYSTEM DESCRIPTION

This chapter describes the SuperStack® II PathBuilder® S330 and SuperStack® II PathBuilder® S310 WAN access switches (PathBuilder S330/S310), and lists PathBuilder S330 and PathBuilder S310 system specifications. It includes the following sections:

- PathBuilder S330/S310 Overview
- Specifications
- Options and Parts List

PathBuilder S330/S310 Overview

The PathBuilder S330 WAN access switch provides cost-effective T1/nxT1 or E1/nxE1 connections between local campus and enterprise networks via private leased line or public carrier ATM services so you can extend high-speed Internet access, Frame Relay, and ATM network service, as well as voice and video, out to your branch offices. Using the built-in ATM Forum standard-based inverse multiplexing capabilities, you can integrate voice, video, and high-speed data services over the same WAN link.

The PathBuilder S330 and PathBuilder S310 use basically the same hardware, with the PathBuilder S330 providing more interfaces. The following subsections describe the features of each unit in greater detail.

PathBuilder S330 Features

The PathBuilder S330 base platform offers the following features:

- *T1/nxT1 ATM UNI or E1/nxE1 ATM UNI* with up to four interfaces for aggregated high-speed of 6Mbps WAN access. Each user-to-network interface (UNI) can be used alone or bundled into a group using the Inverse Multiplexing for ATM (IMA) standard, accommodating branch office growth from a single T1/E1 (1.5/2 Mbps) bandwidth to four T1s/E1s (6/8 Mbps).

The PathBuilder S330 allows up to 70 msec of differential delay between T1s/E1s in a single IMA bundle. The unit also supports an automatic mechanism for removing failed lines from an IMA bundle, ensuring the resiliency required for your mission-critical applications.

- *Multiple connections to Ethernet segments over ATM WAN* and support of bridging, including learning, aging, filtering, and Spanning Tree, through the Ethernet module.
- *Support of Frame Relay (service and network) interworking, ATM DXI, and SDLC/HDLC pass-through*, through the high-performance serial frame data interface.

- *Choice of either single-mode or multi-mode OC3/STM-1 (separate units),* through the OC3/STM-1 module. Single-mode enables higher-speed trunking if you have access to fiber WAN, while multi-mode is ideal for connecting high-speed servers, switches, or hubs equipped with multi-mode fiber connections.
- *Three expansion slots,* allowing you to add other advanced features, such as T1-DSX or E1 CBR for voice and video, voice compression, or DS3/E3.
- *4x switch switching architecture,* including four priority queues (three queues shaped and one bulk shaper) with user-defined queue sizes and early and partial packet discard capability.
- *Device management* via VT100 menu-driven interface, Telnet, or SNMP, with local, remote, and in-band access.

The following optional modules are available for use with the PathBuilder S330:

- *The four-port CBR module* services traffic generated by your existing PBXs, channels, T1/E1 multiplexers, CSU/DSUs, and video conferencing devices. The CBR module consists of one V.35/RS-449 and three T1-DSX or E1 interfaces, which support both structured and unstructured services, in accordance with the ATM Forum's Circuit Emulation Service (CES) specifications. The CBR module provides a smooth migration from legacy CBR service (PBX/voice/video) to ATM service. It also supports all relevant ATM and T1/E1 standards, ensuring easy integration of existing equipment into new ATM networks.
- *The one-port Voice Compression module (VCM)* is similar in function to the CBR module, but it employs compression algorithms that allow more voice calls to be placed through the same bandwidth. The VCM's T1-DSX/E1 interface connects to a PBX trunk, which may use CAS or CCS signaling. Its 24/31 DSO channels can carry individual voice, fax, modem, or data connections. You can also bundle multiple DSOs to provide connections for high-rate applications such as video conference or multiple-link PPP. For CCS, a DSO is used as an ISDN D-channel for carrying signal messages.
- *The DS3/E3 module* provides a DS3 or E3 interface, typically used for terminating/accessing the public or private ATM WAN services. However, depending on your local applications, you can also use these modules for taking local DS3 or E3 ATM traffic across the WAN.

Figure 1 shows the PathBuilder S330 with the optional CBR module installed in expansion slot 7, Voice Compression module in slot 8, and DS3/E3 UNI module in slot 9.

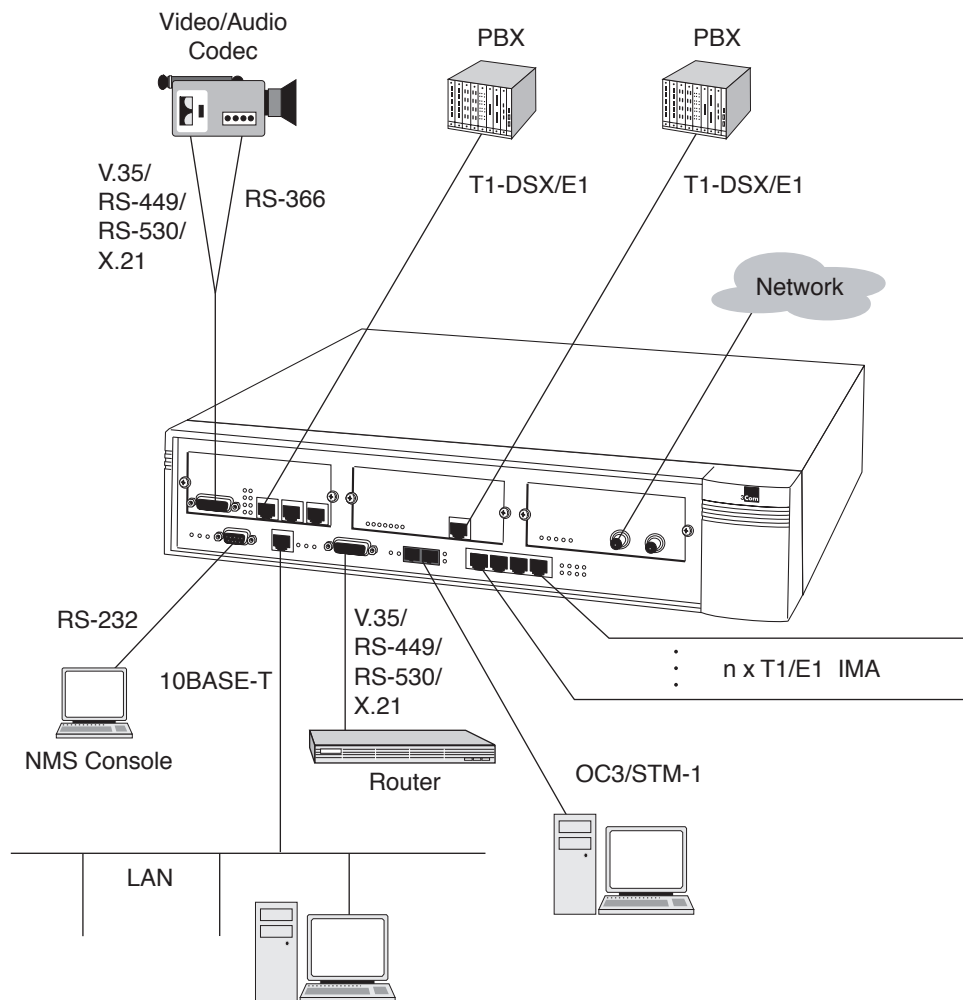
Figure 1 PathBuilder S330 WAN Access Switch

PathBuilder S310 Features

The PathBuilder S310 is a feature-restricted version of the PathBuilder S330 providing remote site CPE access. Its physical appearance is the same as that of the PathBuilder S330 but its software does not enable all the ports. You can upgrade from the PathBuilder S310 to the PathBuilder S330 (multi-mode fiber model) simply by purchasing software.

The PathBuilder S310 base platform offers the following features:

- *Single T1/E1 UNI.*
- *Multiple connections to Ethernet segments over ATM WAN and support of bridging, including learning, aging, and filtering, through the Ethernet module.*
- *Support of Frame Relay (service and network) interworking, ATM DXI, and SDLC/HDL pass-through, through the high-performance serial frame data interface.*
- *Three expansion slots, allowing you to add other advanced features, such as T1-DSX or E1 CBR for voice and video, voice compression, or DS3/E3.*

The following optional modules are available for use with the PathBuilder S310:

- *The two-port CBR module* services traffic generated by your existing PBXs, channels, T1/E1 multiplexers, CSU/DSUs, and video conferencing devices. The CBR module consists of one V.35/RS-449 and one T1-DSX or E1 interface, which support both structured and unstructured services, in accordance with the ATM Forum's Circuit Emulation Service (CES) specifications. The CBR module provides a smooth migration from legacy CBR service (PBX/voice/video) to ATM service. It also supports all relevant ATM and T1/E1 standards, ensuring easy integration of existing equipment into new ATM networks.
- *The one-port Voice Compression module (VCM)* is similar in function to the CBR module, but it employs compression algorithms that allow more voice calls to be placed through the same bandwidth. The VCM's T1-DSX/E1 interface connects to a PBX trunk, which may use CAS or CCS signaling. Its 24/31 DSO channels can carry individual voice, fax, modem, or data connections. You can also bundle multiple DSOs to provide connections for high-rate applications such as video conference or multiple-link PPP. For CCS, a DSO is used as an ISDN D-channel for carrying signal messages.

Figure 2 shows the PathBuilder S310, with the optional CBR module installed in expansion slot 7 and the Voice Compression module in slot 8.

Figure 2 PathBuilder S310 WAN Access Switch

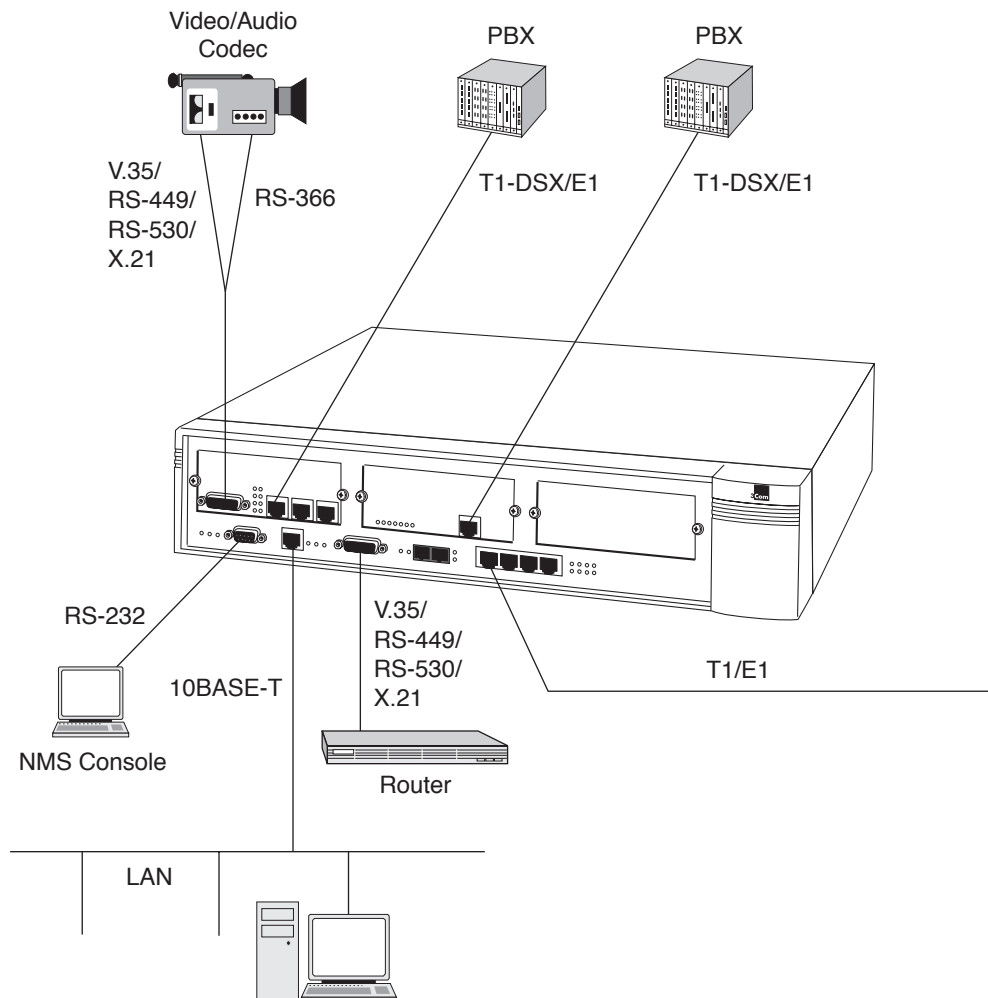

Application Support

The PathBuilder S330/S310 supports the following applications:

- S330 Only*
 - 4 x T1/E1 IMA function on the trunk, up to four trunk groups (individual T1s/E1s)
 - Single T1/E1 for PathBuilder S310
- S330 Only*
 - OC3/STM-1 UNI port interface (multi-mode or single-mode fiber), compliant with ATM Forum's UNI 3.1, ANSI T1.105
 - Ethernet interface and bridge function, bridged RFC 1483 and Spanning Tree
 - Serial V.35/RS-449/RS-530/X.21 interface frame module, including DXI protocol, basic frame relay protocol (DLCI to VP/VC conversion), and transparent HDLC mode of operation
 - Structured and unstructured CBR T1-DSX/E1 and V.35/RS-449/RS-530/X.21 interface
 - Dynamic bandwidth allocation for structured voice CBR ports—stored signaling bits are checked and bandwidth is released when an on-hook (idle) condition is detected
 - RS-366-based video dial feature, supporting point-to-point and multi-point video conferencing
 - Voice compression, supporting voice activity detection, fax relay, DTMF relay, and G.729A, G.726, and G.711 compression algorithms.
- S330 Only*
 - DS3/E3 UNI interface
 - Local management via a VT100 terminal (or a PC emulating one) connected directly to the PathBuilder S330/S310, or through a Telnet session.
 - Software downloading via TFTP, FTP, or direct via RS232
 - Built-in, menu-driven software for configuring modules, ports, virtual circuits, and bridges; setting loopbacks; and collecting and displaying alarms.

Key Benefits

The PathBuilder S330/S310 provides the following key benefits:

- Complete integration into existing application environments by supporting legacy data, video, and voice applications, thereby avoiding costly forklift upgrades.
- Video dial feature supports point-to-point and multi-point dialed video conferencing over ATM networks, including:
 - RS-366 video dial
 - Static call routing for all destinations
 - Ideal for video equipment such as H320
 - Dynamic bandwidth allocation at both the V.35/RS-366 port and the T1-DSX/E1 port on the CBR module
 - Video session dialed through SNMP interface via Telnet and RS232
 - Simulation of a switched ISDN network over an ATM network
- S330 Only*
 - Standards-based IMA implementation; the PathBuilder S330 offers T1/nxT1 and E1/nxE1 ATM access with up to four T1/E1 connections, allowing you to scale up WAN bandwidth as your traffic increases. Each user-to-network interface (UNI) can be used alone or bundled into a group, providing up to 6/8 Mbps aggregated WAN access speed.

- Easily upgradable; no additional hardware required to move from the PathBuilder S310 to the PathBuilder S330; update your system simply by purchasing a software upgrade.
- A sophisticated traffic management system allows management of a mix of applications simultaneously, with features such as deep buffers, traffic shaping, QoS (Quality of Service), and early packet discard, to give you the most effective wide-area ATM bandwidth use and ensure applications integrity.
- Embedded management includes a full IP stack (Telnet, TFTP, and SNMP) and flash memory for sophisticated yet simple network management.
- Comprehensive feature support, including resiliency of nxT1/E1 IMA (S330 only) and redundant power for protection against power failure, ensures maximum application and network uptime.
- 3Com SuperStack II compliance provides common look and feel hardware and integrated network management solutions.
- 3Com SuperStack II Redundant Power Supply (RPS).

Specifications

Table 4 lists complete specifications for the PathBuilder S330 WAN access switch. Table 5 lists complete specifications for the PathBuilder S310 WAN access switch. Specifications are subject to change without notice.

Table 4 PathBuilder S330 System Specifications

SYSTEM SPECIFICATIONS

Ethernet 10 Base T	1
V.35/RS422	1
OC3/STM-1	1 (single-mode or multi-mode)
T1/E1 UNI	4
Mechanical:	
Shelf dimensions	3.5" x 17" x 15.25" (H x W D)
19" rack mountable	Yes (with brackets)
Rack mount spacing	2 RMS
Cooling	2 fans @ 37 CRM each (deregulated 20%)
Unit weight (approx.)	15 lbs. per shelf
Shipping weight (approx.)	20 lbs. per shelf
Input power requirements	90-264 VAC, 50-60 Hz (110/220 self sensing), standard grounded outlet or -42 to -60 VDC
Power consumption	60 watts typical, 90 watts max
Maximum current	1.5A @110VAC 0.75A @ 220VAC 3A @ 48VDC
Environmental:	
Operating temperature	0° to 45° C
Storage temperature	-40° to 70°C
Humidity	95% @ +40°C (non-condensing)
Altitude	14000 ft.

(continued)

Table 4 PathBuilder S330 System Specifications

Regulatory compliance

Safety	UL listed (1950, 3rd edition) CSA 22.2 EN60950 FCC Part 68
Emissions	FCC Part 15, Class A

STANDARDS

ATM Forum	UNI 3.x, T1/E1 CES 2.0, IMA, ATM DXI 1.0
ANSI	T1.403, T1.617 Annex D
TIA/EIA	EIA232, 574, 449/422/423, 366
AT&T	Pubs 62411 and 54016
Frame Relay Forum	FRF.5 and FRF.8
IETF RFCs	1213, 1211, 1483, 1490, 1406, 1493, 1643

MOTHERBOARD SPECIFICATIONS

Main microprocessor	RISC
Memory usage	Flash EPROM, 8Mbytes DRAM, 16Mbytes

Front panel LEDs:

Common	Power, Status, Alert
Ethernet	Tx, Rx, Link
Serial	TD, RD
OC3/STM-1	Alert, Active
T1 (1-4)	Alert, Active

Management Interface

Interface type	RS-232C
Connector type	Female DB-9
Connector pinouts	PIN 1 - Carrier Detect PIN 2 - Rx Data PIN 3 - Tx Data PIN 4 - DTR PIN 5 - Signal Ground PIN 6 - DSR PIN 7 - RTS PIN 8 - CTS

(continued)

Table 4 PathBuilder S330 System Specifications**Ethernet Interface**

Number of ports	1
Interface type	VC level, dual leaky bucket, 56Kbps to 6Mbps
Connector type	RJ48
Connector pinouts	PIN 1 - Tx+ PIN 2 - Tx- PIN 3 - Rx+ PIN 4 - PIN 5 - PIN 6 - Rx- PIN 7 - PIN 8 -
Data support	10Base-T, IEEE 802.3
ATM support	Bridging with filtering, RFC 1483 (LLC_SNAP)
Shaping	AAL5, peak rate
Forwarding rate	Greater than 7000pps

n x T1 / n x E1 Interface

Number of ports	4
Type of interface	T1 or E1 (with integral CSU and DSX)
Connector type	RJ48C or G703 coax with E1 Balun Adapter
Connector pinouts	PIN 1 - Receive ring PIN 2 - Receive Tip PIN 3 - PIN 4 - Transmit ring PIN 5 - Transmit Tip PIN 6 - PIN 7 - PIN 8 -
Line Framing	ESF, SF (D4), or No Framing for T1 G. 703/704 for E1
Line Coding	B8ZS for T1 (AMI for special applications) HDB3 for E1
ATM framing	HEC (ITU-T G.804), I.432
ATM support	T1/E1 UNI (with IMA)
LBO	0, 7.5, 15.0, 22.5dB (CSU) 0 ~655 ft. (DSX)
Electrical interface	CSU/DSX
Attenuation	0, 7.5, 15db
Payload scrambling	Yes
(continued)	

Table 4 PathBuilder S330 System Specifications**OC3/STM-1 Interface**

Number of ports	1
Interface type	SR or IR
Connector type	Duplex SC
Line Code	SONET scrambled, NRZ
Fiber Type	Multi-mode or single-mode
Wavelength	1300nm
Receiver input power	-30.0 dBm minimum (SR), -31 dBm minimum (IR) -14.0 dBm maximum (SR), -8 dBm maximum (IR)
Transmit output power	-19.0 dBm minimum (SR), -15 dBm minimum (IR) -14.0 dBm maximum (SR), -8 dBm maximum (IR)
Clock	Internal or external
Application support	VP or VC level, UNI
ATM support	ATM UNI, 3.x

Serial Interface

Number of ports	1
Interface type	HD 60-pin (DCE or DTE), female; V.35/RS-449/EIA530 (through cable converters)
Data support	Transparent HDLC/SDLC, Frame Relay, ATM DXI
ATM support	AAL5
Clock	DCE or DTE, Internal or external (smooth clock)
Shaping	VC level, dual leaky bucket
Data rates:	56Kbps to 6Mbps
Minimum	56 Kbps
Maximum	6 Mbps
Maximum cable length	50 feet @ 8 Mbps
Clock outputs	Smooth clocks on transmit and receive lines to DTE
Connector type on unit	MOLEX 60-pin female
Connector type on V.35 cable converter	35-pin Winchester, female for DCE, male for DTE

Connector pinouts	<u>A Side</u>	<u>B Side</u>
Chassis Ground	A	
Signal Ground	B	
Req to Send	C	
Clear to Send	D	
Data Set Ready	E	
Rcv Line Sig Det	F	
Send Data	P	S
Receive Data	R	T
Terminal Timing	U	W
Receive Timing	V	X
Send Timing	Y	AA

(continued)

Table 4 PathBuilder S330 System Specifications

Connector type at end of RS-422 cable	DB-37 subminiature, female for DCE, male for DTE		
Connector pinouts	<u>A Side</u>	<u>B Side</u>	
Chassis Ground	1		
Send Data	4	22	
Send Timing	5	23	
Receive Data	6	24	
Req to Send	7	25	
Receive Timing	8	26	
Clear to Send	9	27	
Terminal Ready	12	30	
Receiver Ready	13	31	
Terminal Timing	17	35	
Signal Ground	19		
Connector type at end of EIA530 cable	DB-25 subminiature, female for DCE, male for DTE		
Connector pinouts	<u>A Side</u>	<u>B Side</u>	
Chassis Ground	1		
Send Data	2	14	
Send Timing	15	12	
Receive Data	3	16	
Req to Send	4	19	
Receive Timing	17	9	
Clear to Send	5	13	
Terminal Ready	20	23	
Receiver Ready	8	10	
Terminal Timing	24	11	
Signal Ground	7		

(continued)

Table 4 PathBuilder S330 System Specifications

Connector type at end of X.21 cable	DB-15 subminiature, female for DCE, male for DTE			
X.21 DTE cable pinouts (60-pin connector) to DB-15 male	Signal Name	Pin # on 60-pin	Pin # on DB-15	Direction (for serial port)
	Frame GND	46	1	
	Circuit GND	15	8	
	RTS	9,10	3,10	OUT
	CTS	1,2	5,12	IN
	DSR			IN
	DCD (not used; tristate when in DTE mode)			
	DTR			OUT
	LL (not used)			OUT
	SD+	11	2	OUT
	SD-	12	9	OUT
	RD+	28	4	IN
	RD-	27	11	IN
	SCTE+			OUT
	SCTE-			OUT
	SCR+	26	6	IN
	SCR-	25	13	IN
	SCT+			IN
	SCT-			IN
	Shorting GR 1	47,48,49		
	Shorting GR 2	51, 52		

(continued)

Table 4 PathBuilder S330 System Specifications

X.21 DCE cable pinouts (60-pin connector) to DB-15 female	Signal Name	Pin # on 60-pin	Pin # on DB-15	Direction (for QSIM)
	Frame GND	46	1	
	Circuit GND	15	8	
	RTS	1,2	3,10	IN
	CTS	9,10	5,12	OUT
	DSR			OUT
	DCD (not used; tristate when in DTE mode)			
	DTR			IN
	LL (not used)			
	SD+	28	2	IN
	SD-	27	9	IN
	RD+	11	4	OUT
	RD-	12	11	OUT
	SCTE+			IN
	SCTE-			IN
	SCR+	24	6	OUT
	SCR-	23	13	OUT
	(tristate SCR + and - when in DTE mode, double term., double buffer)			
	SCT+			OUT
	SCT-			OUT
	Shorting			
	GR 1	47,48		
	Shorting			
	GR 2	51, 52		

(continued)

Table 4 PathBuilder S330 System Specifications**CBR MODULE SPECIFICATIONS**

Number of ports	4
Interface type(s)	3 direct T1-DSX/E1, 1 DSU/CSU
T1-DSX/E1 physical	3 each RJ48
Impedance	100 Ohms
Framing	D4 or ESF
Line Coding	AMI or B8ZS
LBO	0 - 655 feet
Serial	HD-pin; V.35/RS-449/EIA530/X.21 (see Serial Interface, under "Motherboard Specifications, above, for connector pinouts)
Clock	DCE, Internal
Front panel LEDs (1-3)	ALARM, Inservice
Data rates	n x 56Kbps or n x 64Kbps (structured; n = 1, 2, 3, 4, 6, 8, 12, 24) or 1.544 Mbps (unstructured)
ATM support	CAS/CCS support with Dynamic bandwidth reallocation
Timing	AAL1, ATM CES 2.0
Cell Delay Variation Tolerance	Looped, system, adaptive, SRTS
Class of Service	24 msec (T1-DSX), 32 msec (E1)
T1-DSX/E1connector type	CBR
T1-DSX/E1 connector pinouts	RJ48 or G703 coax with E1 Balun Adapter
	PIN 1 - Receive ring
	PIN 2 - Receive Tip
	PIN 3 -
	PIN 4 - Transmit ring
	PIN 5 - Transmit Tip
	PIN 6 -
	PIN 7 -
	PIN 8 -

(continued)

Table 4 PathBuilder S330 System Specifications

Connector type at end of V.35/RS-366 cable	DB-25 subminiature, female for DCE	<u>From</u>	<u>To</u>
Connector pinouts	Frame Ground	J1-46	J2-A
	Circuit Ground	J1-45	J2-B
	RTS	J1-35	J2-C
	CTS	J1-42	J2-D
	DSR	J1-43	J2-E
	DCD	J1-44	J2-F
	DTR	J1-34	J2-H
	LL	J1-33	J2-K
	SD+	J1-28	J2-P
	SD-	J1-27	J2-S
	RD+	J1-18	J2-R
	RD-	J1-17	J2-T
	SCTE+	J1-26	J2-U
	SCTE-	J1-25	J2-W
	SCR+	J1-22	J2-V
	SCR-	J1-21	J2-X
	SCT+	J1-20	J2-Y
	SCT-	J1-19	J2-AA
	366_RI	J1-50	J2-J
	366_PWI	J1-29	J3-6
	366_ACR	J1-31	J3-3
	366_PND	J1-32	J3-5
	366_DSC	J1-36	J3-13
	366_DLO	J1-37	J3-22
	366_NB1	J1-38	J3-14
	366_NB2	J1-39	J3-15
	366_NB4	J1-40	J3-16
	366_NB8	J1-41	J3-17
	366_CRQ	J1-47	J3-4
	366_DPR	J1-59	J3-2
	Signal Ground	J1-56	J3-7
	SHT GRP 1	J1-49 J1-48	2
	SHT GRP 2	J1-50 J1-51	2
	SHT GRP 3	J1-53 J1-54 J1-55 J1-56	2

(continued)

Table 4 PathBuilder S330 System Specifications**VOICE COMPRESSION MODULE SPECIFICATIONS**

Number of ports	1
Interface type(s)	1 direct T1-DSX/E1
T1-DSX/E1 physical	1 each RJ48
Impedance	100 Ohms
Framing	D4 or ESF
Line Coding	AMI or B8ZS
LBO	0 - 655 feet
Clock	DCE, Internal
Front panel LEDs (1-7)	PWR, FAIL, TEST, STS 0, STS 1, INS, ALM
Data rates	n x 56Kbps or n x 64Kbps (structured; n = 1, 2, 3, 4, 6, 8, 12, 24)
ATM support	CAS/CCS support with Dynamic bandwidth reallocation AAL1, AAL5
Timing	Looped, system
Class of Service	AAL5
T1-DSX/E1 connector type	RJ48 or G703 coax with E1 Balun Adapter
T1-DSX/E1 connector pinouts	PIN 1 - Receive ring PIN 2 - Receive Tip PIN 3 - PIN 4 - Transmit ring PIN 5 - Transmit Tip PIN 6 - PIN 7 - PIN 8 -
Frame Relay support	FRF.5, FRF.8
Compression Types	G.729A, G. 726, G.711, voice activity detection, fax relay, DTMF relay

DS3/E3 EXPANSION MODULE SPECIFICATIONS

Number of ports	1
Interface type(s)	DS3, E3
Connector type	Coax, BNC
ATM Framing	HEC, PLCP
LBO	0-250, 250-450
Line Coding	B8ZsS (DS3), HDB3 (E3)
Line Framing	M23 and C-BIT (DS3), G.751-PLCP, G.804/G832-HEC (E3)

Table 5 PathBuilder S310 System Specifications**SYSTEM SPECIFICATIONS**

Ethernet 10 Base T	1
V.35/RS422	1
T1/E1 UNI	1
Mechanical:	
Shelf dimensions	3.5" x 17" x 15.25" (H x W D)
19" rack mountable	Yes (with brackets)
Rack mount spacing	2 RMS
Cooling	2 fans @ 37 CRM each (deregulated 20%)
Unit weight (approx.)	15 lbs. per shelf
Shipping weight (approx.)	20 lbs. per shelf
Input power requirements	90-264 VAC, 50-60 Hz (110/220 self sensing), standard grounded outlet or -42 to -60 VDC
Power consumption	60 watts typical, 100 watts max
Maximum current	1.5A @110VAC 0.75A @ 220VAC 3A @ 48VDC
Environmental:	
Operating temperature	0° to 45° C
Storage temperature	-40° to 70°C
Humidity	95% @ +40°C (non-condensing)
Altitude	14000 ft.
Regulatory compliance	
Safety	UL listed (1950, 3rd edition) CSA 22.2 EN60950 FCC Part 68
Emissions	FCC Part 15, Class A
Homologation	Pending
STANDARDS	
ATM Forum	UNI 3.x, T1/E1 CES 2.0, IMA, ATM DXI 1.0
ANSI	T1.403, T1.617 Annex D
TIA/EIA	EIA232, RS-449/422/423, 366
AT&T	Pubs 62411 and 54016
Frame Relay Forum	FRF.5 and FRF.8
IETF RFCs	1213, 1211, 1483, 1490, 1406, 1493, 1643
MOTHERBOARD SPECIFICATIONS	
Main microprocessor	RISC
Memory usage	Flash EPROM, 8Mbytes DRAM, 16Mbytes

(continued)

Table 5 PathBuilder S310 System Specifications

Front panel LEDs:

Common	Power, Status, Alert
Ethernet	Tx, Rx, Link
Serial	TD, RD
T1	Alert, Active

Management Interface

Interface type	RS-232C
Connector type	Female DB-9
Connector pinouts	PIN 1 - Carrier Detect PIN 2 - Rx Data PIN 3 - Tx Data PIN 4 - DTR PIN 5 - Signal Ground PIN 6 - DSR PIN 7 - RTS PIN 8 - CTS

Ethernet Interface

Number of ports	1
Interface type	VC level, dual leaky bucket, 56Kbps to 6Mbps
Connector type	RJ48
Connector pinouts	PIN 1 - Tx+ PIN 2 - Tx- PIN 3 - Rx+ PIN 4 - PIN 5 - PIN 6 - Rx- PIN 7 - PIN 8 -
Data support	10Base-T, IEEE 802.3
ATM support	Bridging with filtering, RFC 1483 (LLC_SNAP)
Shaping	AAL5, VBR/UBR
Forwarding rate	Greater than 7000pps

(continued)

Table 5 PathBuilder S310 System Specifications**T1/E1 UNI Interface**

Number of ports	1
Type of interface	T1/E1 (with integral CSU and DSX)
Connector type	RJ48C or G703 coax with E1 Balun Adapter
Connector pinouts	PIN 1 - Receive ring PIN 2 - Receive Tip PIN 3 - PIN 4 - Transmit ring PIN 5 - Transmit Tip PIN 6 - PIN 7 - PIN 8 -
Framing	D4 or ESF
Line Coding	AMI or B8ZS
ATM framing	G.804 HEC
ATM support	T1/E1 UNI
LBO	0, 7.5, 15.0, 22.5dB (CSU) 0 ~655 ft. (DSX)
Electrical interface	CSU/DSX
Attenuation	0, 7.5, 15db
Payload scrambling	Yes
(continued)	

Table 5 PathBuilder S310 System Specifications

Serial Interface

Number of ports	1
Interface type	HD 60-pin (DCE or DTE), female; V.35/RS-449/EIA530 (through cable converters)
Data support	Transparent HDLC/SDLC, Frame Relay, ATM DXI
ATM support	AAL5
Clock	DCE or DTE, Internal or external (smooth clock)
Shaping	VC level, dual leaky bucket
Data rates:	56Kbps to 6Mbps
Minimum	56 Kbps
Maximum	6 Mbps
Maximum cable length	50 feet @ 8 Mbps
Clock outputs	Smooth clocks on transmit and receive lines to DTE
Connector type on unit	MOLEX 60-pin female
Connector type on V.35 cable converter	35-pin Winchester, female for DCE, male for DTE

Connector pinouts	<u>A Side</u>	<u>B Side</u>
Chassis Ground	A	
Signal Ground	B	
Req to Send	C	
Clear to Send	D	
Data Set Ready	E	
Rcv Line Sig Det	F	
Send Data	P	S
Receive Data	R	T
Terminal Timing	U	W
Receive Timing	V	X
Send Timing	Y	AA

Connector type at end of RS-422 cable DB-37 subminiature, female for DCE, male for DTE

Connector pinouts	<u>A Side</u>	<u>B Side</u>
Chassis Ground	1	
Send Data	4	22
Send Timing	5	23
Receive Data	6	24
Req to Send	7	25
Receive Timing	8	26
Clear to Send	9	27
Terminal Ready	12	30
Receiver Ready	13	31
Terminal Timing	17	35
Signal Ground	19	

(continued)

Table 5 PathBuilder S310 System Specifications

Connector type at end of EIA530 cable	DB-25 subminiature, female for DCE, male for DTE			
Connector pinouts		<u>A Side</u>	<u>B Side</u>	
	Chassis Ground	1		
	Send Data	2	14	
	Send Timing	15	12	
	Receive Data	3	16	
	Req to Send	4	19	
	Receive Timing	17	9	
	Clear to Send	5	13	
	Terminal Ready	20	23	
	Receiver Ready	8	10	
	Terminal Timing	24	11	
	Signal Ground	7		
Connector type at end of X.21 cable	DB-15 subminiature, female for DCE, male for DTE			
X.21 DTE cable pinouts (60-pin connector) to DB-15 male	<u>Signal Name</u>	<u>Pin # on 60-pin</u>	<u>Pin # on DB-15</u>	<u>Direction (for serial port)</u>
	Frame GND	46	1	
	Circuit GND	15	8	
	RTS	9,10	3,10	OUT
	CTS	1,2	5,12	IN
	DSR			IN
	DCD (not used; tristate when in DTE mode)			
	DTR			OUT
	LL (not used)			OUT
	SD+	11	2	OUT
	SD-	12	9	OUT
	RD+	28	4	IN
	RD-	27	11	IN
	SCTE+			OUT
	SCTE-			OUT
	SCR+	26	6	IN
	SCR-	25	13	IN
	SCT+			IN
	SCT-			IN
	Shorting GR 1	47,48,49		
	Shorting GR 2	51, 52		

(continued)

Table 5 PathBuilder S310 System Specifications

X.21 DCE cable pinouts (60-pin connector) to DB-15 female	Signal Name	Pin # on 60-pin	Pin # on DB-15	Direction (for QSIM)
	Frame GND	46	1	
	Circuit GND	15	8	
	RTS	1,2	3,10	IN
	CTS	9,10	5,12	OUT
	DSR			OUT
	DCD (not used; tristate when in DTE mode)			
	DTR			IN
	LL (not used)			IN
	SD+	28	2	IN
	SD-	27	9	IN
	RD+	11	4	OUT
	RD-	12	11	OUT
	SCTE+			IN
	SCTE-			IN
	SCR+	24	6	OUT
	SCR-	23	13	OUT
	(tristate SCR + and - when in DTE mode, double term., double buffer)			
	SCT+			OUT
	SCT-			OUT
	Shorting GR 1	47,48		
	Shorting GR 2	51, 52		

(continued)

Table 5 PathBuilder S310 System Specifications**CBR MODULE SPECIFICATIONS**

Number of ports	2
Interface type(s)	1 direct T1-DSX/E1, 1 DSU/CSU
T1-DSX/E1 physical	RJ48 or G703 coax with E1 Balun Adapter
Impedance	100 Ohms
Framing	D4 or ESF
Line Coding	AMI or B8ZS
LBO	0 - 655 feet
Serial	HD-pin; V.35/RS-449/EIA530/X.21 (see Serial Interface, under "Motherboard Specifications, above, for connector pinouts)
Clock	DTE or DCE, Internal or external
Front panel LEDs (1-3)	ALARM Inservice
Data rates	n x 56Kbps or n x 64Kbps (structured; n = 1, 2, 3, 4, 6, 8, 12, 24) or 1.544 Mbps (unstructured)
	CAS/CCS support with Dynamic bandwidth reallocation
ATM support	AAL1, ATM CES 2.0
Timing	Looped, system adaptive, SRTS
Cell Delay Variation Tolerance	24 msec (T1), 32 msec (E1)
Class of Service	CBR
T1-DSX/E1 connector type	RJ48 or G703 coax with E1 Balun Adapter
T1-DSX/E1 connector pinouts	PIN 1 - Receive ring PIN 2 - Receive Tip PIN 3 - PIN 4 - Transmit ring PIN 5 - Transmit Tip PIN 6 - PIN 7 - PIN 8 -

(continued)

Table 5 PathBuilder S310 System Specifications

Connector type at end of V.35/RS-366 cable	DB-25 subminiature, female for DCE	<u>From</u>	<u>To</u>
Connector pinouts	Frame Ground	J1-46	J2-A
	Circuit Ground	J1-45	J2-B
	RTS	J1-35	J2-C
	CTS	J1-42	J2-D
	DSR	J1-43	J2-E
	DCD	J1-44	J2-F
	DTR	J1-34	J2-H
	LL	J1-33	J2-K
	SD+	J1-28	J2-P
	SD-	J1-27	J2-S
	RD+	J1-18	J2-R
	RD-	J1-17	J2-T
	SCTE+	J1-26	J2-U
	SCTE-	J1-25	J2-W
	SCR+	J1-22	J2-V
	SCR-	J1-21	J2-X
	SCT+	J1-20	J2-Y
	SCT-	J1-19	J2-AA
	366_RI	J1-50	J2-J
	366_PWI	J1-29	J3-6
	366_ACR	J1-31	J3-3
	366_PND	J1-32	J3-5
	366_DSC	J1-36	J3-13
	366_DLO	J1-37	J3-22
	366_NB1	J1-38	J3-14
	366_NB2	J1-39	J3-15
	366_NB4	J1-40	J3-16
	366_NB8	J1-41	J3-17
	366_CRQ	J1-47	J3-4
	366_DPR	J1-59	J3-2
	Signal Ground	J1-56	J3-7
	SHT GRP 1	J1-49 J1-48	2
	SHT GRP 2	J1-50 J1-51	2
	SHT GRP 3	J1-53 J1-54 J1-55 J1-56	2

(continued)

Table 5 PathBuilder S310 System Specifications**VOICE COMPRESSION MODULE SPECIFICATIONS**

Number of ports	1
Interface type(s)	1 direct T1-DSX/E1
T1-DSX/E1 physical	1 each RJ48
Impedance	100 Ohms
Framing	D4 or ESF
Line Coding	AMI or B8ZS
LBO	0 - 655 feet
Clock	DCE, Internal
Front panel LEDs (1-7)	PWR, FAIL, TEST, STS 0, STS 1, INS, ALM
Data rates	n x 56Kbps or n x 64Kbps (structured; n = 1, 2, 3, 4, 6, 8, 12, 24)
ATM support	CAS/CCS support with Dynamic bandwidth reallocation AAL1, AAL5
Timing	Looped, system
Class of Service	AAL5
T1-DSX/E1 connector type	RJ48 or G703 coax with E1 Balun Adapter
T1-DSX/E1 connector pinouts	PIN 1 - Receive ring PIN 2 - Receive Tip PIN 3 - PIN 4 - Transmit ring PIN 5 - Transmit Tip PIN 6 - PIN 7 - PIN 8 -
Frame Relay support	FRF.5, FRF.8
Compression Types	G.729A, G.726, G.711, voice activity detection, fax relay, DTMF relay

Options and Parts List

The tables below list available PathBuilder S330/S310 options. Contact 3Com or your VAR with the appropriate part number for ordering and pricing information.

Table 6 PathBuilder S330 Part Numbers

Part Number	Description
3C63300A-AC-NC	SuperStack II PathBuilder S330 ATM WAN Access Switch Base System with AC Ethernet, V.35/RS-449 data, OC3/STM-1 UNI mmf, and n x T1 WAN.
3C63300A-DC-NC	SuperStack II PathBuilder S330 ATM WAN Access Switch Base System with DC Ethernet, V.35/RS-449 data, OC3/STM-1 UNI mmf, and n x T1 WAN
3C63303A-AC-NC	SuperStack II PathBuilder S330 ATM WAN Access Switch Base System with AC Ethernet, V.35/RS-449 data, OC3/STM-1 UNI smf, and n x T1 WAN
3C63303A-DC-NC	SuperStack II PathBuilder S330 ATM WAN Access Switch Base System with DC Ethernet, V.35/RS-449 data, OC3/STM-1 UNI smf, and n x T1 WAN
3C63304-NC	SuperStack II PathBuilder S330E ATM WAN Access Switch Base System with AC Ethernet, V.35/RS-449 data, OC3/STM-1 UNI mmf, and n x E1 WAN
3C63305-NC	SuperStack II PathBuilder S330E ATM WAN Access Switch Base System with DC Ethernet, V.35/RS-449 data, OC3/STM-1 UNI mmf, and n x E1 WAN
3C63306-NC	SuperStack II PathBuilder S330E ATM WAN Access Switch Base System with AC Ethernet, V.35/RS-449 data, OC3/STM-1 UNI smf, and n x E1 WAN
3C63307-NC	SuperStack II PathBuilder S330E ATM WAN Access Switch Base System with DC Ethernet, V.35/RS-449 data, OC3/STM-1 UNI smf, and n x E1 WAN
3C63301	Optional Four-Port CBR Module with three T1-DSX ports and one V.35/RS-449 port
3C63308	Optional Four-Port CBR Module with three E1 ports and one V.35/RS-449 port
3C63311	Optional DS1 Voice Compression Module + 1 SIMM
3C63314	Optional E1 Voice Compression Module + 1 SIMM
3C63313	Voice Compression SIMM
3C63324	Optional single-port DS3 Expansion Module
3C63325	Optional single-port E3 Expansion Module

Table 7 PathBuilder S310 Part Numbers

Part Number	Description
3C63502A-NC	SuperStack II PathBuilder S310 ATM WAN Access Switch Base System with AC Ethernet, V.35/RS-449 data, and one T1 UNI.
3C63503A-NC	SuperStack II PathBuilder S310 ATM WAN Access Switch Base System with DC Ethernet, V.35/RS-449 data, and one T1 UNI.
3C63508-NC	SuperStack II PathBuilder S310E ATM WAN Access Switch Base System with AC Ethernet, V.35/RS-449 data, and one E1 UNI.
3C63509-NC	SuperStack II PathBuilder S310E ATM WAN Access Switch Base System with DC Ethernet, V.35/RS-449 data, and one E1 UNI.

(continued)

Table 7 PathBuilder S310 Part Numbers (continued)

Part Number	Description
3C63504	Optional Two-Port CBR Module with one T1-DSX port and one V.35/RS-449 port
3C63504	Optional Two-Port CBR Module with one E1 port and one V.35/RS-449 port
3C63311	Optional DS1 Voice Compression Module + 1 SIMM
3C63314	Optional E1 Voice Compression Module + 1 SIMM
3C63313	Voice Compression SIMM

Table 8 Ancillary Items

Part Number	Description
3C16071	SuperStack II Advanced RPS Chassis only (eight slots)
3C16073	SuperStack II Advanced RPS 100 W Module

Table 9 Cables

Part Number	Description
3C16079	SuperStack II Advanced RPS Y-cable
3C63319	V.35/RS-366 CBR Y -cable
3C63905	Fiber cable; SC, multi-mode, to SC 8 m/25 ft.
3C63906	Fiber cable; SC, multi-mode, to FC 8 m/25 ft.
3C63907	Fiber cable; SC, multi-mode, to ST 8 m/25 ft.
3C63908	Fiber cable; SC, single-mode, to SC 8 m/25 ft.
3C63909	Fiber cable; SC, single-mode, to FC 8 m/25 ft.
3C63910	Fiber cable; SC, single-mode, to ST 8 m/25 ft.
3C63913	V.35 cable; HD 60-pin male to V.35 34-pin male, 2m / 6ft (crossover DTE)
3C63914	V.35 cable; HD 60-pin male to V.35 34-pin male, 2m / 6ft)
3C63920	RS-449 cable; HD 60-pin male, straight, to RS-449 37-pin male, 2m/6ft
3C63921	RS-449 cable; HD 60-pin male, straight, to RS-449 37-pin female, 2m/6ft
3C63922	EIA530 cable; HD 60-pin male, straight, to EIA530 25-pin male, 2m/6ft
3C63923	EIA530 cable; HD 60-pin male, straight, to EIA530 25-pin female, 2m/6ft
3C63902	T1/E1 cable; RJ48, shielded straight, to RJ48, 8m/25ft
3C63903	T1/E1 cable; RJ48, shielded crossover, to RJ48, 8m/25ft
3C63904	E1 Balun Adapter; RJ48 120 ohm to Coax 75 ohm - 2M/6Ft

2

INSTALLATION

This chapter tells you how to mechanically and electrically install SuperStack® II PathBuilder® S330 and SuperStack® II PathBuilder® S310 WAN access switches (PathBuilder S330/S310) in your network and describes the PathBuilder S330/S310 ports and modules. It contains the following sections:

- Receiving and Inspecting the PathBuilder S330/S310
- Installation Overview
- Installation Procedures



Before using this chapter for an actual installation, read through it at least once to familiarize yourself with the overall process.

Receiving and Inspecting the PathBuilder S330/S310

When you receive the PathBuilder S330/S310, do the following:

- 1 Unpack and inspect the PathBuilder S330/S310 equipment for any damage that might have occurred during shipment.
- 2 Inventory the equipment against the shipping notice.
- 3 Save the boxes and packing materials in the event there is damage or in case you need to reship the unit at a future date.
- 4 If anything is damaged or missing, contact the shipper and 3Com immediately.



CAUTION: *Many of the integrated circuits on the modules are sensitive to static electricity. Do not remove the plug-in modules from their shelves without wearing a properly-grounded antistatic wrist strap.*

Installation Overview

Figure 3 summarizes the overall installation procedure for the PathBuilder S330/S310.

Figure 3 General Installation Procedure

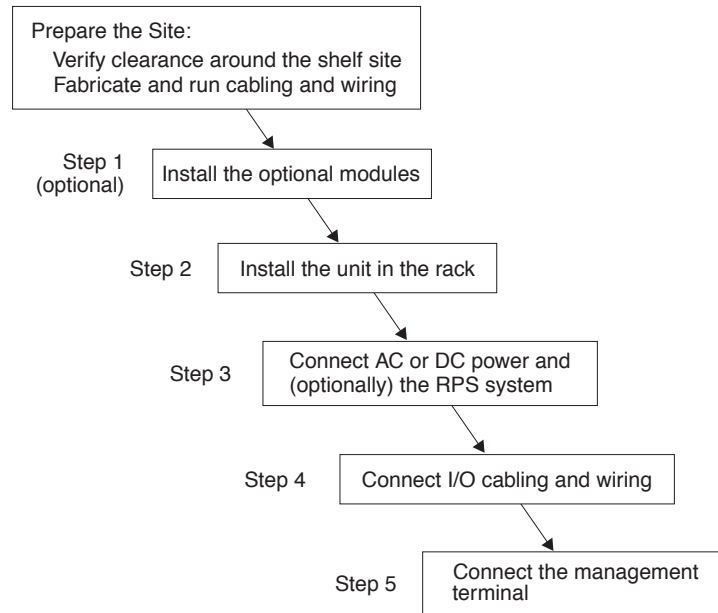

Figure 4 shows an example of a PathBuilder S330 configuration with all of the associated cabling connected.

Figure 4 PathBuilder S330 Full System Configuration

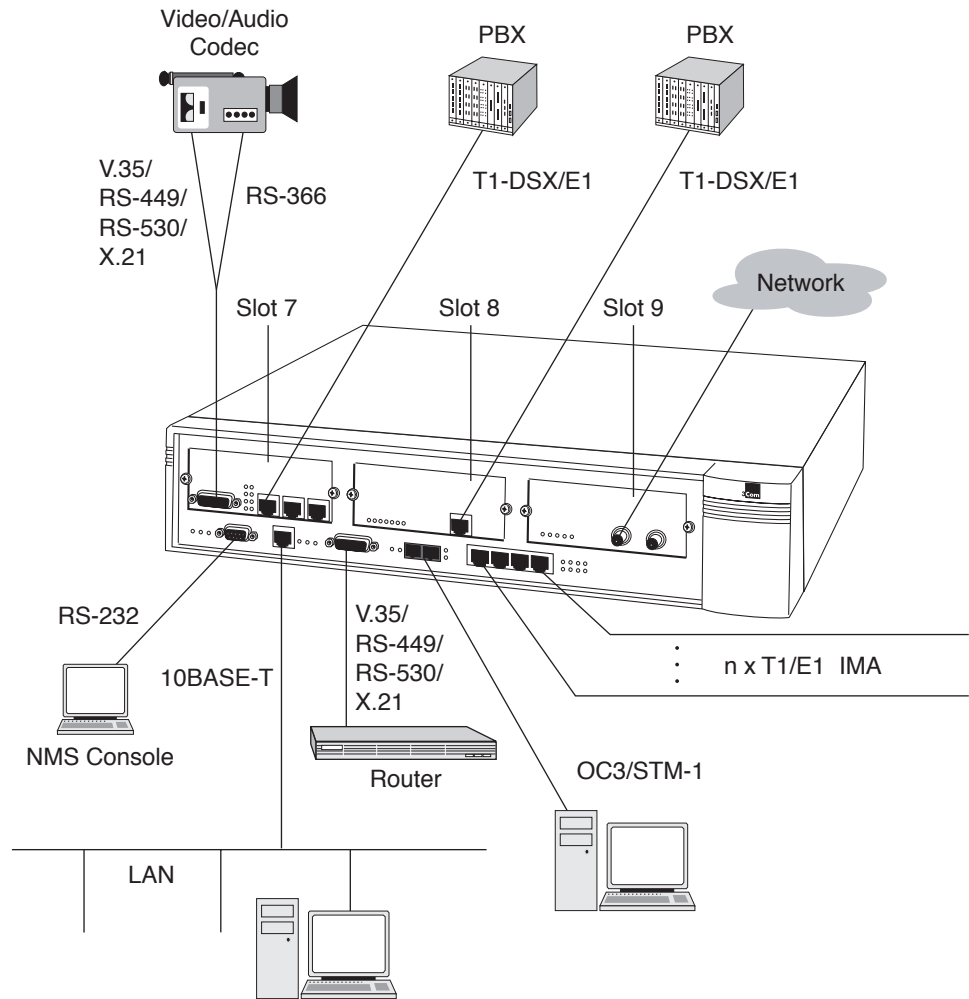
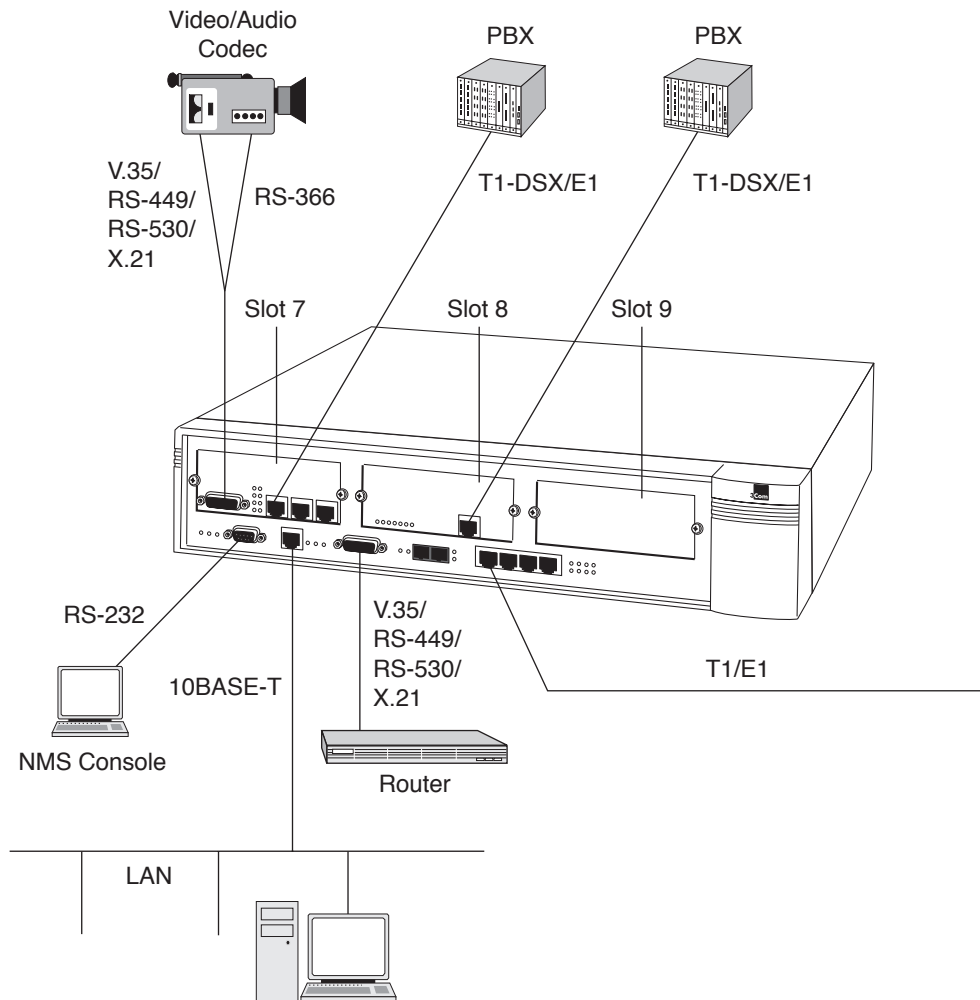

Figure 5 shows an example of a PathBuilder S310 with all of the associated cabling connected.

Figure 5 PathBuilder S310 Full System Configuration



Site Requirements

The operating site for the PathBuilder S330/S310 must meet the following requirements:

- Be within the maximum distances to the port and trunk connections, as well as the NMS terminal
- Have interconnect cabling and wiring ready and labeled
- Have a dedicated source of switched and fused AC power or a primary DC source.
- Be within the operating environment for the PathBuilder S330/S310, as specified under "Specifications" in Chapter 1.
- Provide clearance for making all connections and performing maintenance.

Installation Procedures

This section provides detailed instructions for completing the steps in the installation procedure illustrated earlier in Figure 3.

Step 1 (Optional): Install the Optional Modules in the Unit

This section tells you how to install the optional modules in the PathBuilder S330/S310 chassis.

The PathBuilder S330/S310 supports three optional modules:

- **CBR module**—a board consisting of one V.35/RS-366/RS-449/RS-530/X.21 interface and three T1-DSX or E1 interfaces (one T1-DSX or E1 interface for the PathBuilder S310). It services traffic generated by your existing PBXs, channels, T1/E1 multiplexers, CSU/DSUs, and video conferencing devices. Install the CBR module in expansion slot 7. Figure 6 shows the CBR module connections.

Figure 6 CBR Module Connections

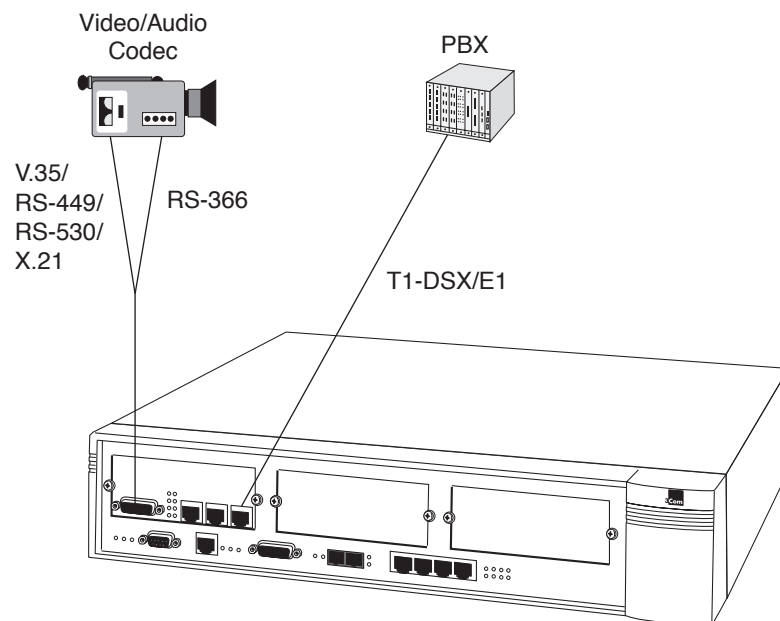

- **Voice compression module**—a board consisting of one T1-DSX or E1 interface. It services traffic generated by your existing PBXs, channels, T1/E1 multiplexers, CSU/DSUs, and video conferencing devices. Install the Voice Compression module in slot 7 or slot 8. Figure 7 shows the VCM module connections.

Figure 7 Voice Compression Module Connections

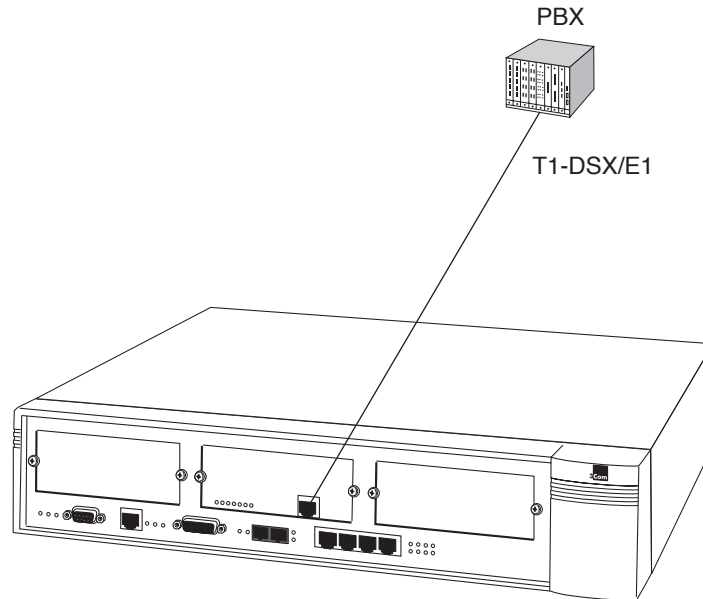

- **DS3/E3 module**—a board consisting of one DS3 or E3 port. It is typically used for terminating/accessing the public or private ATM WAN services. However, depending on your local applications, you can also use the DS3/E3 module for taking local DS3 or E3 ATM traffic across the WAN. Install the DS3/E3 module in expansion slot 9. Figure 8 shows the DS3/E3 module connections.

Figure 8 DS3/E3 Module Connections

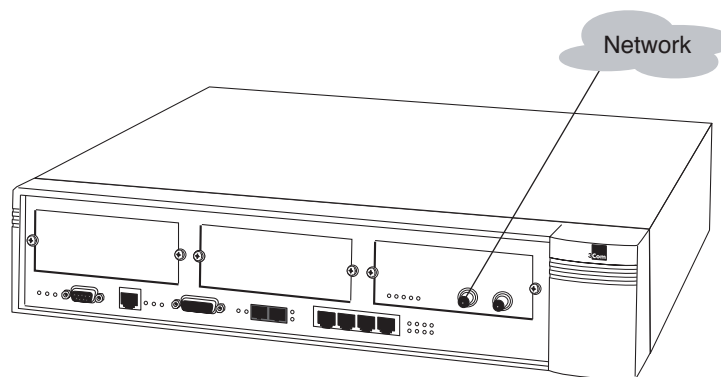

Installing the Optional Modules in the Unit

To install an option module in the unit, follow these steps:



CAUTION: Many of the integrated circuits on the modules are sensitive to static electricity. When installing plug-in modules, always wear a properly-grounded anti-static wrist strap.

- 1 Turn off the power and unplug the unit.
- 2 Open the unit.
 - a Remove the eight screws (three on each side and two in the rear), as shown in Figure 9.

Figure 9 Removing the Eight Screws from the PathBuilder S330/S310 Unit

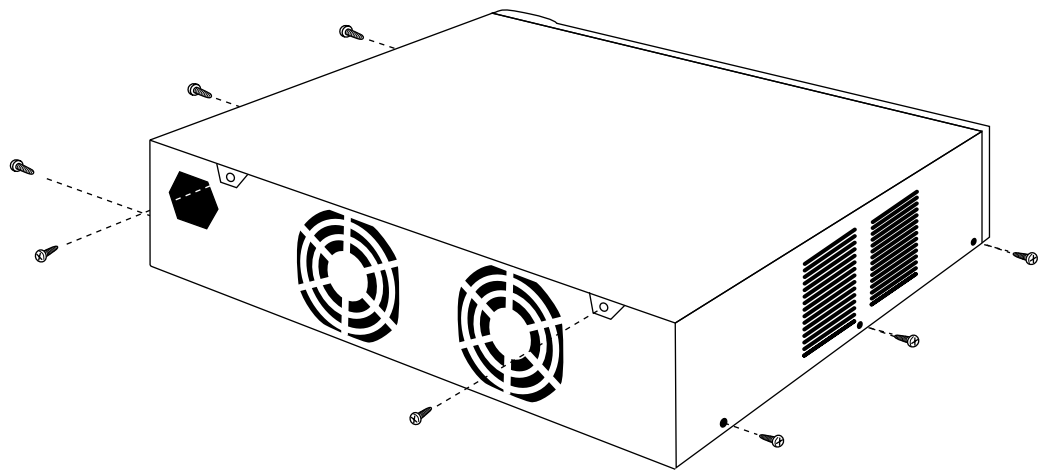

- b Push the cover back (arrow 1) and lift it up from the rear (arrow 2), as shown in Figure 10.

Figure 10 Removing the PathBuilder S330/S310 Cover

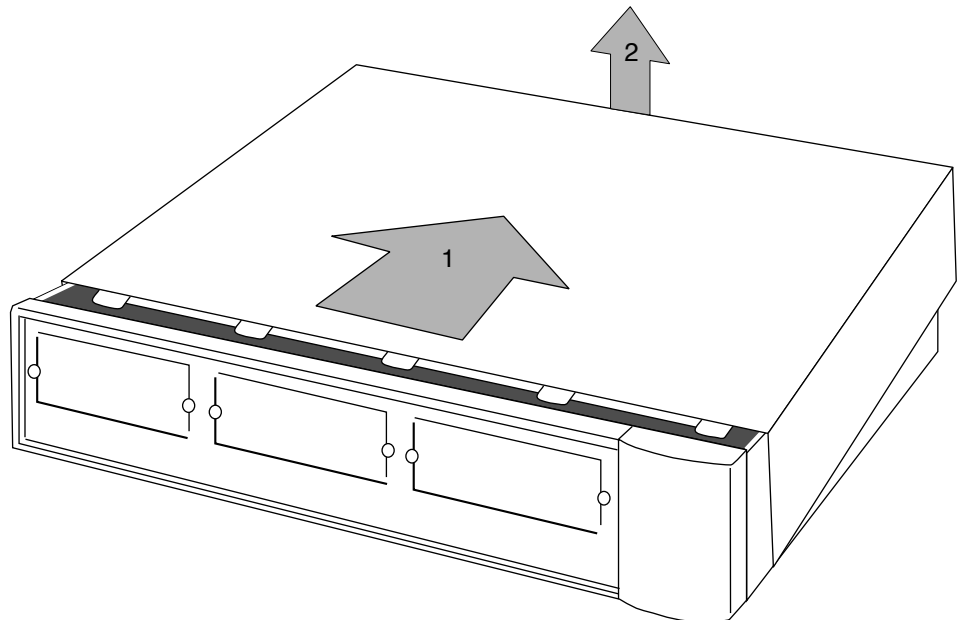

- 3 Remove the cover plate from the slot into which you want to install the optional module by unscrewing the two retaining screws. Figure 11 shows the retaining screws being removed from slot 7.

Figure 11 Removing the Cover Plate from Slot 7

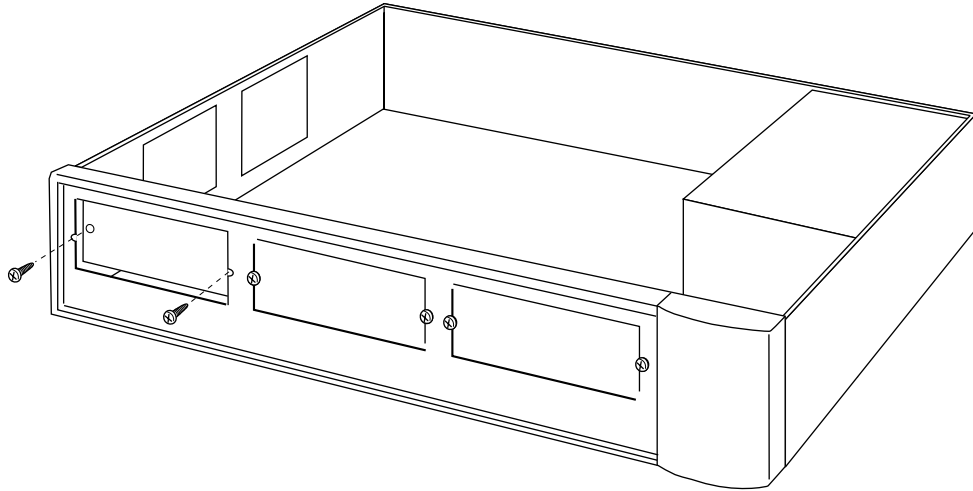

- 4 Insert the optional card into the appropriate slot (7 for the CBR module; 7 or 8 for the VCM; 9 for the DS3/E3 module). Figure 12 shows the CBR module being installed into slot 7. Installation for the other modules is the same.

Figure 12 Inserting an Optional Module (CBR Module into Slot 7)

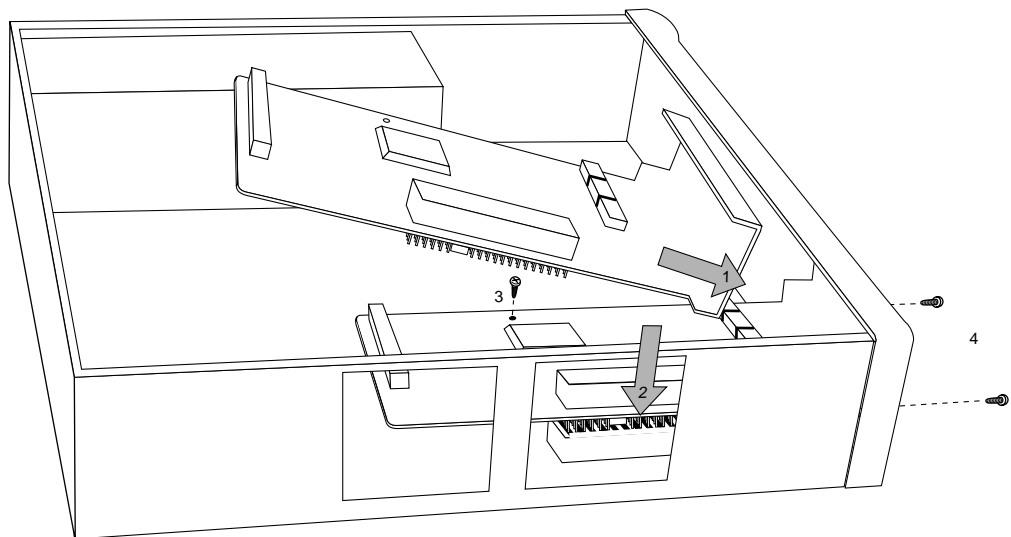

- a Slide the faceplate into position (arrow 1).
- b Line up the pins carefully and press down from above the pin connector (arrow 2).



By aligning the screw hole with the standoff, you will also line up the pins.

- c Install the screw supplied with the optional module through the card into the stand-off post (item 3).
- d Install the two screws in the optional module's faceplate (item 4).

- 5 Replace the unit's cover.
 - a Slide the cover back into place so that the five tabs go under the lip of the front panel (arrow 1) and push it down at the rear (arrow 2), as shown in Figure 13.

Figure 13 Replacing the PathBuilder S330/S310 Cover

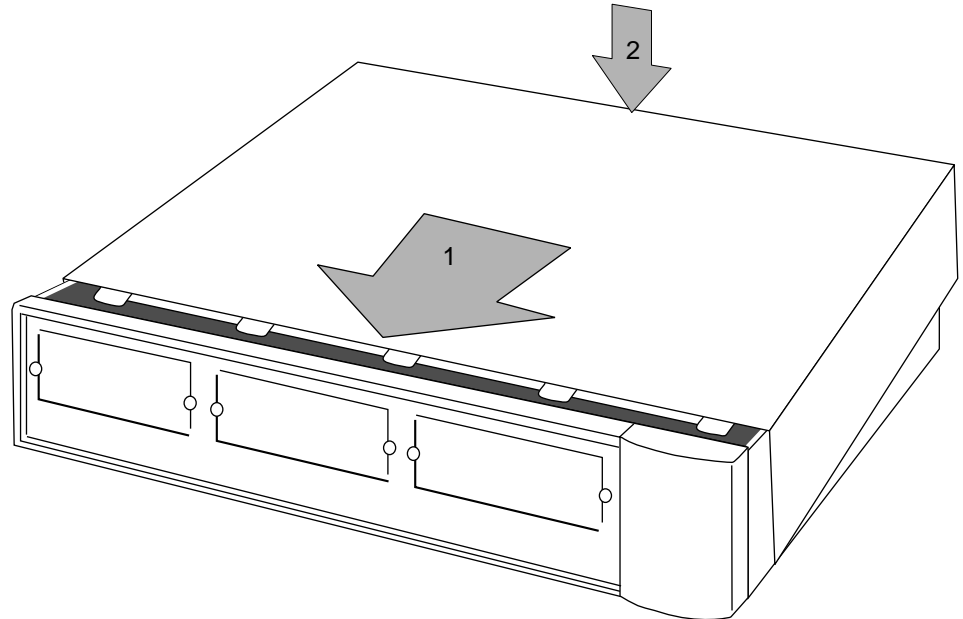

- b Secure the cover with the eight assembly screws you removed in step 1a.

Step 2: Install the Unit in the Rack

In a normal rack mount configuration the PathBuilder S330/S310 shelf is 3.5" x 17" x 15.5" including cables. Since the equipment is cooled with two internal fans, clearance at the top is not needed; however, convection cooled equipment must not be mounted directly under the shelf. Allow at least one rack unit clearance below the unit. See Figure 14 for details. If the PathBuilder S330/S310 is mounted in an enclosure, plan on enough clearance at the front for cable and wiring service loops.



CAUTION: Many of the integrated circuits on the modules are sensitive to static electricity. Do not handle the plug-in modules without wearing a properly grounded antistatic, wrist strap. When removing the modules from the shelf, place them printed-circuit side down on a nonconducting, static-free, flat surface.

To mount the shelf, follow these steps:

- 1 Attach the rack-mount ears to the unit, following the instructions supplied with the ears.



CAUTION: When attaching the rack-mount ears, you must use the factory-supplied screws. Using screws other than those supplied with the rack-mount ears voids your warranty and could damage the PCB.

- 2 Adjust the rack-mount ears if necessary for 19" installation. See Figure 14.

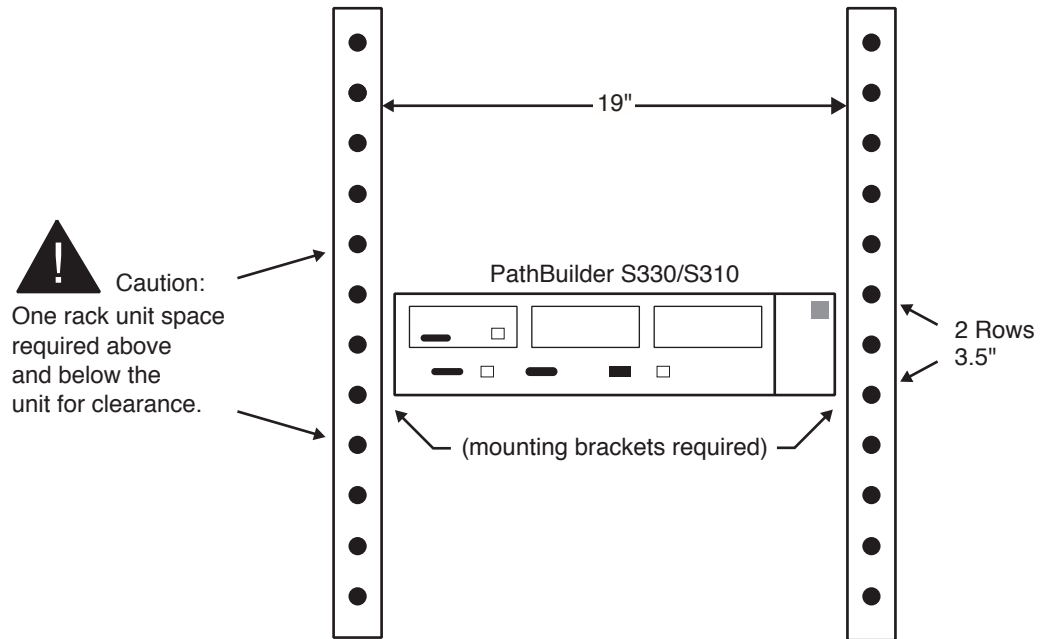

CAUTION: Do not block the ventilation openings on the top and bottom of the unit during installation. A minimum of 1 rack unit (1.75") space is required.

Figure 14 Rack Mounting Ear Configuration

- 3 Support the shelf in its mounting place and attach the mounting hardware.

Step 3: Connect AC or DC Power and (optionally) the RPS System

You connect the AC/DC power at the rear of the PathBuilder S330/S310 shelf. Table 10 outlines the specifications for the AC/DC Source.

Table 10 AC/DC Source Specifications

Input Power Requirements	90-264 VAC, 50-60Hz, standard grounded outlet -42 to -60 VDC, Optional AC: 14 AWG wire, Belden type 19364 DC: minimum 14 AWG wire, listed type TC tray cable with three conductors
Power Consumption	60 Watts typical, 90 Watts maximum
Maximum Current	1.5 A @ 110VAC 0.75A @ 220VAC 3A @ 48VDC

To connect AC or DC power, follow these steps:



WARNING: Before handling AC/DC power leads, disconnect all power supply cords and always have a partner close by who is familiar with first aid for electrical shock.



CAUTION: *CENTRALIZED 48VDC UNITS -To be installed only in Restricted Access Areas (dedicated equipment rooms, equipment closets, etc.) in accordance with Articles 110-16 or 110-17, and 110-18 of the National Electrical Code, ANSI/NFPA No.70.*

- 1 Turn off the AC/DC power source and connect the AC/DC leads to the front of the shelf. Dress the leads to the rack, leaving a service loop.
- 2 Turn on AC/DC power and verify that the POWER indicator on the power supply is on and that the fans are running. Figure 15 shows the shelf fill for the AC/DC power application.

Figure 15 Shelf Fill for AC/DC Power Application

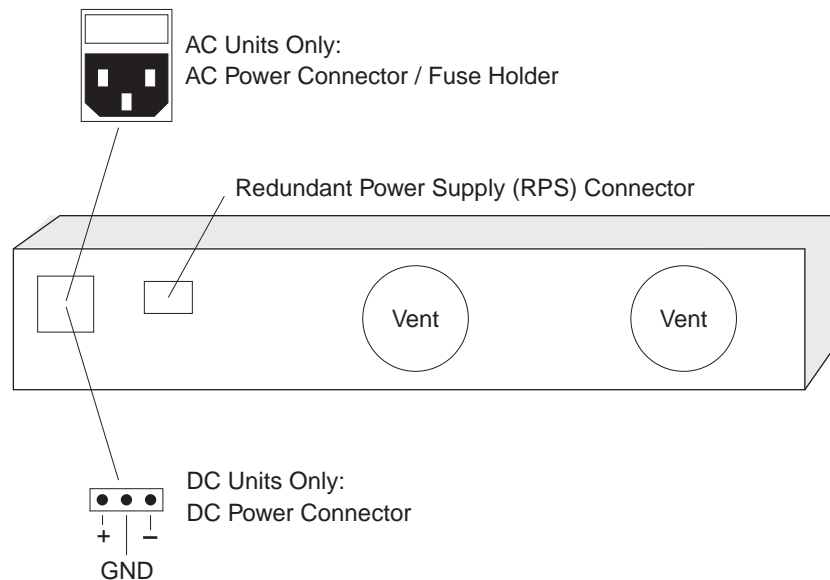

Installing the Optional RPS System

The PathBuilder S330/S310 also supports the SuperStack II Redundant Power Supply (RPS). Figure 15 above shows the location of the RPS. Only connect a 3Com RPS, option 3C16073, to this socket. For details, follow the installation instructions in the guide accompanying the RPS.

Figure 16 illustrates the power supply socket and fuse.

Figure 16 SuperStack II RPS Power Supply Socket and Fuse

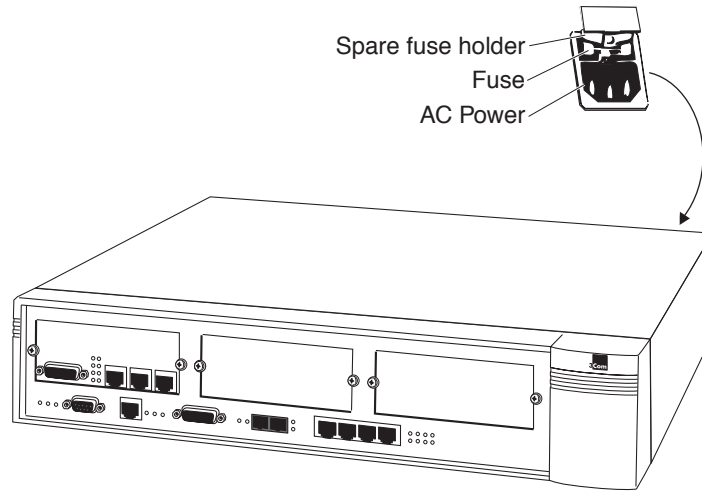

The PathBuilder S330/S310 automatically adjusts to the supply voltage. The fuse is suitable for both 110V AC and 220-240V AC operations.

To change the fuse, follow these steps:

- 1 Turn of the power and unplug the unit.



CAUTION: Ensure that the power cord is disconnected before opening the fuse holder cover.

- 2 Release the fuse holder by gently levering a small screwdriver under the fuse holder catch. Use only 2A anti-surge type fuses of the same type and manufacture as the original.
- 3 Remove the old fuse and replace it with a new one.
- 4 Close the fuse holder.

Step 4: Connect I/O Cabling

The PathBuilder S330/S310 ships with the standard interfaces installed. Unless you have purchased optional modules, you do not need to install any additional modules. For details about how to install the optional CBR, voice compression, and DS3/E3 UNI modules, see “Step 1 (Optional): Install the Optional Modules in the Unit” earlier in this chapter.

The following LEDs indicate the status of the PathBuilder S330/S310 as a whole. (See Figure 17.)

Power (green)—Illuminates when the unit is turned on.

Status (green)—Illuminates when the CPU completes downloading and flashes in normal state.

Alert (red)—Illuminates when a major alarm is detected in the unit. See Chapter 5 for information about managing system alarms.

Figure 17 PathBuilder S330/S310 Common LEDs

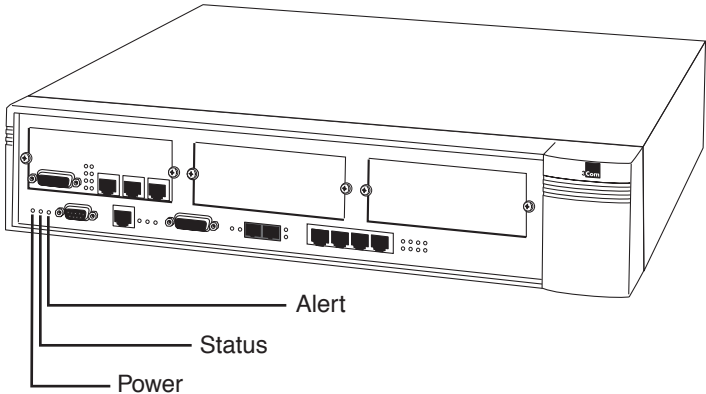
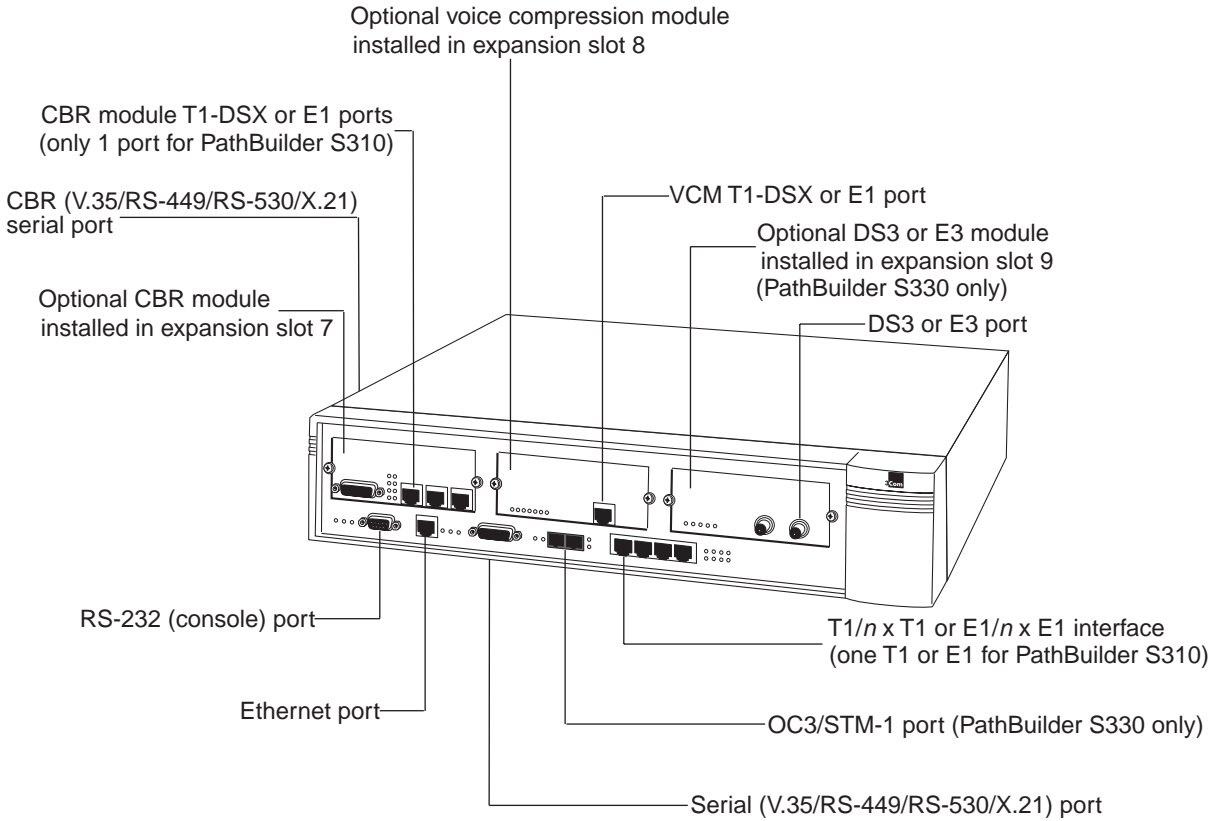

Figure 18 shows the port configuration of a PathBuilder S330/S310.

Figure 18 PathBuilder S330/S310 Ports and CBR Module



The following sections tell you how to make connections to the ports of the PathBuilder S330/S310.

Connecting to the T1/E1 UNI Interface

As shown above in Figure 18, the PathBuilder S330 T1/E1 UNI with IMA interface provides four T1/E1 ports. You can connect a single T1/E1 line to this interface, or connect up to four T1/E1 lines and combine them to form a logical, inverse-multiplexed high-speed link. See “Configuring UNI and IMA Groups” in Chapter 4 for details about setting up IMA groups.



If you are using a G703 coax physical connection to connect the E1 line to the interface, you must use the E1 Balun Adapter (part number 3C63904).

T1/E1 UNI Interface LEDs In addition to the common LEDs described earlier in this chapter, the following LEDs indicate the status of each T1/E1 port. (See Figure 19.)



The PathBuilder S330 has four of each of the following LEDs (one for each T1/E1 port). The PathBuilder S310 has one of each of the following LEDs (for its one T1/E1 port).

ALARM PORT #N (red)—Powers up in the “off” state and illuminates when an alarm condition is detected on the corresponding T1/E1 line.

ONLINE PORT #N (green)—Powers up in the “off” state and illuminates when you set the administrative status of the T1/E1 port to *In Service*. See “Configuring the T1/E1 Interface” in Chapter 4, for details about how to set the administrative status of the T1/E1 ports and/or IMA groups.

Figure 19 PathBuilder S330 T1/E1 UNI LEDs

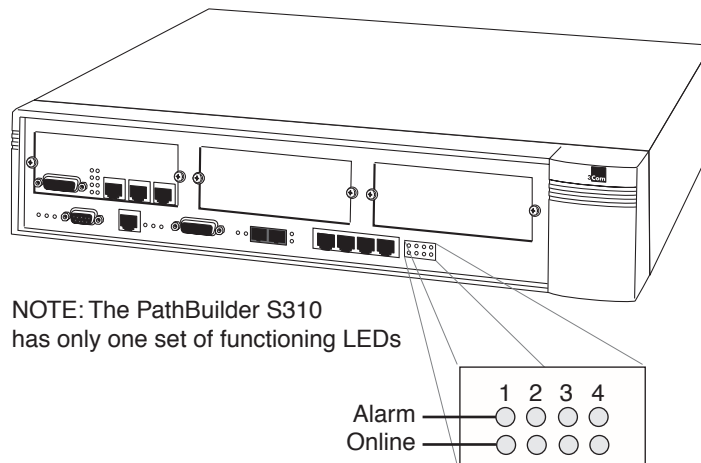

Connecting to the Serial Port

To connect to the serial port, connect a DTE or DCE cable to the MOLEX 60-pin connector on the front of the unit. The cable options for the serial port are:

- DCE V.35—The connector type on the V.35 cable converter is 35-pin Winchester; female.
- DTE/DCE RS-449—The connector type at the end of the RS-449 cable is DB-37 subminiature; female for DCE, male for DTE.
- DTE/DCE EIA530—The connector type at the end of the EIA530 cable is DB-25 subminiature; female for DCE, male for DTE.
- DTE/DCE X.21—The connector type at the end of the X.21 cable is DB-15 subminiature; female for DCE, male for DTE.

The following tables describe the serial port connector pinouts.



Note that PathBuilder S330/S310 cables are compatible with CISCO cables, except for the DCE EIA530 which CISCO does not manufacture.

Table 11 Connector Pinouts for V.35 DTE Cable (60-pin connector) to V.35 Male

Signal Name	Pin # on 60-pin Connector	Pin # on V.35 Connector	Direction (for Serial Port)
Frame GND	46	A	
Circuit GND	45	B	
RTS	42	C	Out
CTS	35	D	In
DSR	34	E	In
DCD	33	F	In
DTR	43	H	Out
LL (not used)	44	K	Out
SD+	18	P	Out
SD-	17	S	Out
RD+	28	R	In
RD-	27	T	In
SCTE+	20	U	Out
SCTE-	19	W	Out
SCR+	26	V	In
SCR-	25	X	In
SCT+	24	Y	In
SCT-	23	AA	In
Shorting GR 1	48, 49		
Shorting GR 2	50, 51, 52		
Shorting GR 3	53, 54, 55, 56		

Table 12 Connector Pinouts for V.35 DCE Cable (60-pin Connector) to V.35 Female

Signal Name	Pin # on 60- pin Connector	Pin # on V.35 Connector	Direction (for Serial Port)
Frame GND	46	A	
Circuit GND	45	B	
RTS	35	C	In
CTS	42	D	Out
DSR	43	E	Out
DCD	44	F	Out
DTR	34	H	In
LL (not used)	33	K	In
SD+	28	P	In
SD-	27	S	In
RD+	18	R	Out
RD-	17	T	Out
SCTE+	26	U	In
SCTE-	25	W	In
SCR+	22	V	Out
SCR-	21	X	Out
SCT+	20	Y	Out
SCT-	19	AA	Out
Shorting GR 1	48, 49		
Shorting GR 2	50, 51,		
Shorting GR 3	53, 54, 55, 56		

Table 13 Connector Pinouts for RS-449 DTE Cable (60-pin connector) to DB-37 Male

Signal Name	Pin # on 60-pin Connector	Pin # on DB-37 Connector	Direction (for Serial Port)
Frame GND	46	1	
Circuit GND	15, 16, 45	19, 20, 37	
RTS	9, 10	7, 25	Out
CTS	1, 2	9, 27	In
DSR	3, 4	11, 29	In
DCD (not used, see DCE cable)	5, 6	13, 31	In
DTR	7, 8	12, 30	Out
LL (not used)	44	10	Out
SD+	11	4	Out
SD-	12	22	Out
RD+	28	6	In
RD-	27	24	In
SCTE+	13	17	Out
SCTE-	14	35	Out
SCR+	26	8	In
SCR-	25	26	In
SCT+	24	5	In
SCT-	23	23	In
Shorting GR 1	48, 49		
Shorting GR 2	51, 52,		

Table 14 Connector Pinouts for RS-449 DCE Cable (60-pin Connector) to DB-37 Female

Signal Name	Pin # on 60-pin Connector	Pin # on DB-37 Connector	Direction (for Serial Port)
Frame GND	46	1	
Circuit GND	15, 16, 30	19, 20, 37	
RTS	1, 2	7, 25	In
CTS	9, 10	9, 27	Out
DSR	7, 8	11, 29	Out
DCD	5, 6	13, 31	Out
DTR	3, 4	12, 30	In
LL (not used)	29	10	In
SD+	28	4	In
SD-	27	22	In
RD+	11	6	Out
RD-	12	24	Out
SCTE+	26	17	In
SCTE-	25	35	In
SCR+	24	8	Out
SCR-	23	26	Out
SCT+	13	5	Out
SCT-	14	23	Out
Shorting GR 1	48, 49		

Table 15 Connector Pinouts for EIA530 DTE cable (60-pin Connector) to DB-25 Male

Signal Name	Pin # on 60-pin Connector	Pin # on DB-25 Connector	Direction (for Serial Port)
Frame GND	46	1	
Circuit GND	45	7	
RTS	9, 10	4, 19	Out
CTS	1, 2	5, 13	In
DSR	3, 4	6, 22	In
DCD (not used, see DCE cable)	5, 6	8, 10	In
DTR	7, 8	20, 23	Out
LL (not used)	44	18	Out
SD+	11	2	Out
SD-	12	14	Out
RD+	28	3	In
RD-	27	16	In
SCTE+	13	24	Out
SCTE-	14	11	Out
SCR+	26	17	In
SCR-	25	9	In
SCT+	24	15	In
SCT-	23	12	In
Shorting GR 1	47, 48, 49		
Shorting GR 2	51, 52,		

Table 16 Connector Pinouts for EIA530 DCE cable (60-pin Connector) to DB-25 Female

Signal Name	Pin # on 60-pin Connector	Pin # on DB-25 Connector	Direction (for Serial Port)
Frame GND	46	1	
Circuit GND	45	7	
RTS	1, 2	4, 19	In
CTS	9, 10	5, 13	Out
DSR	7, 8	6, 22	Out
DCD (not used, see DCE cable)	5, 6	8, 10	Out
DTR	3, 4	20, 23	In
LL (not used)	29	18	In
SD+	28	2	In
SD-	27	14	In
RD+	11	3	Out
RD-	12	16	Out
SCTE+	26	24	In
SCTE-	25	11	In
SCR+	24	17	Out
SCR-	23	9	Out
SCT+	13	15	Out
SCT-	14	12	Out
Shorting GR 1	47, 48, 49		

Table 17 Connector Pinouts for X.21 DTE cable (60-pin Connector) to DB-15 Male

Signal Name	Pin # on 60-pin Connector	Pin # on DB-25 Connector	Direction (for Serial Port)
Frame GND	46	1	
Circuit GND	15	8	
RTS	9, 10	3, 10	Out
CTS	1, 2	5, 12	In
DSR			In
DCD (not used, see DCE cable)			In
DTR			Out
LL (not used)			Out
SD+	11	2	Out
SD-	12	9	Out
RD+	28	4	In
RD-	27	11	In
SCTE+			Out
SCTE-			Out
SCR+	26	6	In
SCR-	25	13	In
SCT+			In
SCT-			In
Shorting GR 1	47, 48		
Shorting GR 2	51, 52,		

Table 18 Connector Pinouts for X.21 DCE cable (60-pin Connector) to DB-15 Female

Signal Name	Pin # on 60-pin Connector	Pin # on DB-25 Connector	Direction (for Serial Port)
Frame GND	46	1	
Circuit GND	15	8	
RTS	1, 2	3, 10	In
CTS	9, 10	5, 12	Out
DSR			Out
DCD (DCD should be tristated when in DTE mode)			Out
DTR			In
LL (not used)			In
SD+	28	2	In
SD-	27	9	In
RD+	11	4	Out
RD-	12	11	Out
SCTE+			In
SCTE-			In
SCR+ (SCR+ and - should be tristated when in DTE mode, double term., double buffer)	24	6	Out
SCR-	23	13	Out
SCT+			Out
SCT-			Out
Shorting GR 1	47, 48		

Serial Port LEDs In addition to the common LEDs described earlier in this chapter, the following LEDs indicate the status of the serial port. See Figure 20.

RD active (green)—Flashes with receiving signals.

TD active (green)—Flashes with transmitting signals.

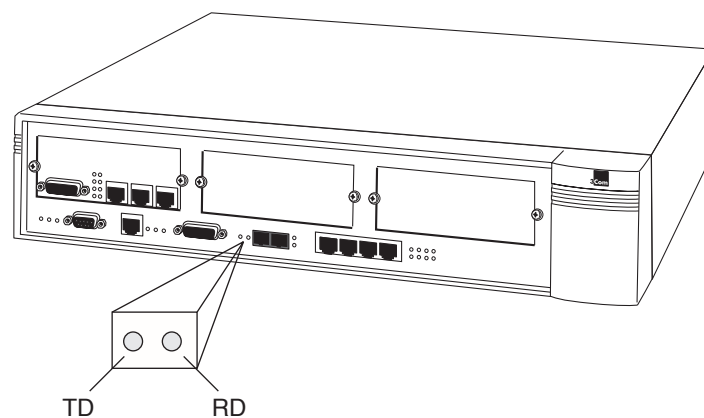
Figure 20 PathBuilder S330/S310 Serial Port LEDs

Connecting to the Ethernet Port

To connect to the Ethernet port, run a cable from the port to the LAN. The Link LED illuminates if you make the connection properly. The cable run from the PathBuilder S330/S310 Ethernet port to the Ethernet LAN connection must be no longer than 100 meters, in compliance with EIA/TIA standards for 10BaseT. This cable length should include service loops at the ends and the complete cable route distances.

Ethernet Port LEDs In addition to the common LEDs described earlier in this chapter, the following LEDs indicate the status of the Ethernet port. See Figure 21.

TX data (green)—Indicates transmit (to the cable) activity. The LED flashes momentarily for each frame sent to the cable.

RX data (green)—Indicates receive (from the cable) activity. The LED flashes momentarily for each frame received from the cable.

Link (green)—Indicates that you have a link to the remote system. If this LED is off, then a problem exists with the remote link. For example, the Ethernet cable may not be connected properly, or the remote Ethernet unit may be down.

Figure 21 PathBuilder S330/S310 Ethernet Port LEDs

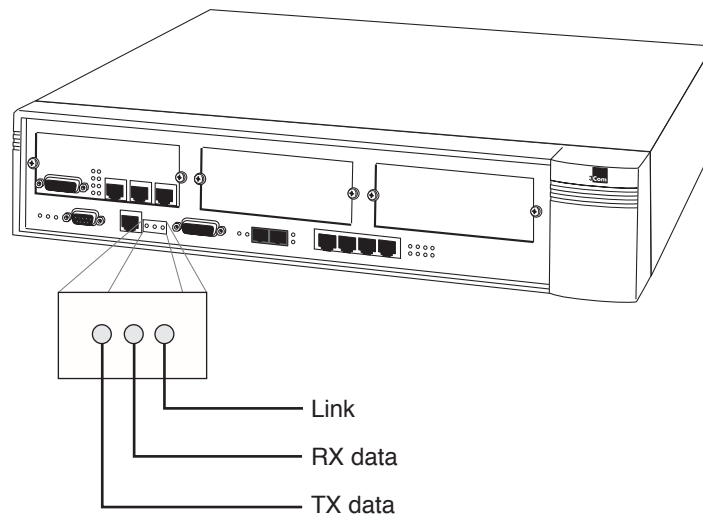

Connecting to the OC3/STM-1 Port

S330 only

The OC3/STM-1 UNI port is equipped with an internal SC-type connector supporting the use of multi-mode or single-mode fiber optic cable, as shown in Figure 22 and Figure 23.

Figure 22 OC3/STM-1 UNI (Multi-Mode Fiber Optic Cable)

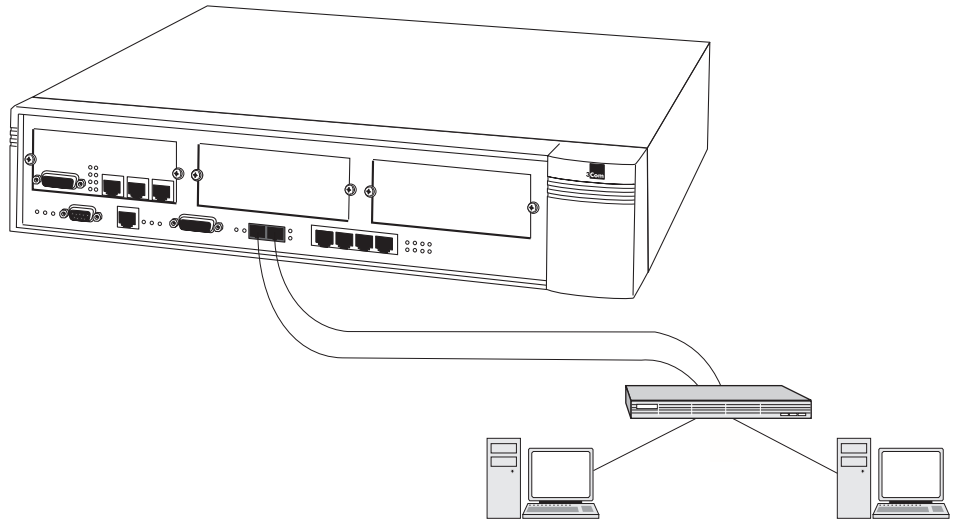
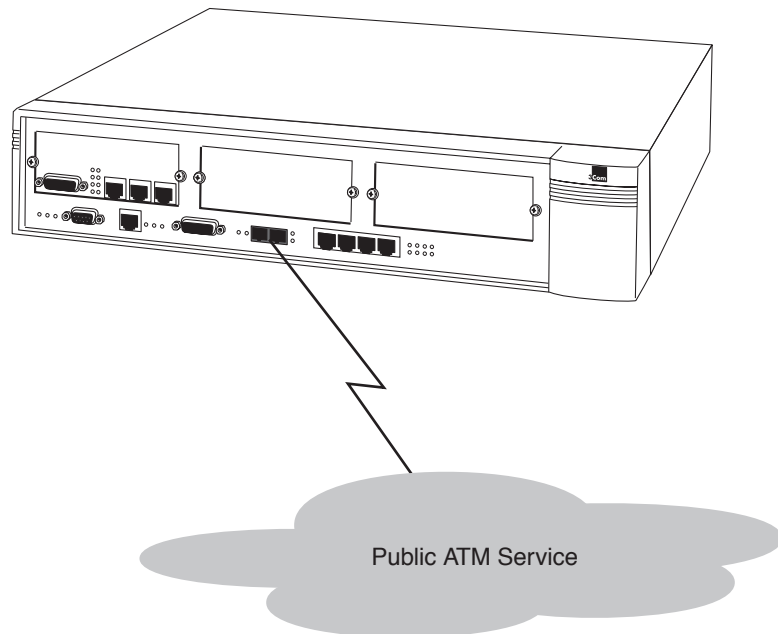

Figure 23 OC3/STM-1 UNI (Single-Mode Fiber Optic Cable)



OC3/STM-1 LEDs In addition to the common LEDs described earlier in this chapter, the following LEDs indicate the status of the OC3/STM-1 port. (See Figure 24.)

OC3/STM-1 Alert (red)—Powers up in the “off” state and illuminates when a Loss of Signal (LOS), Loss of Frame (LOF), Loss of Pointer (LOP), or Loss of ATM Frame (LOAF) condition is detected on the incoming OC3/STM-1. If none of these conditions is present, the OC3/STM-1 ALARM LED is off.

OC3/STM-1 Active (green)—Powers up in the “off” state and illuminates when the OC3/STM-1 is online.

Figure 24 OC3/STM-1 Port LEDs

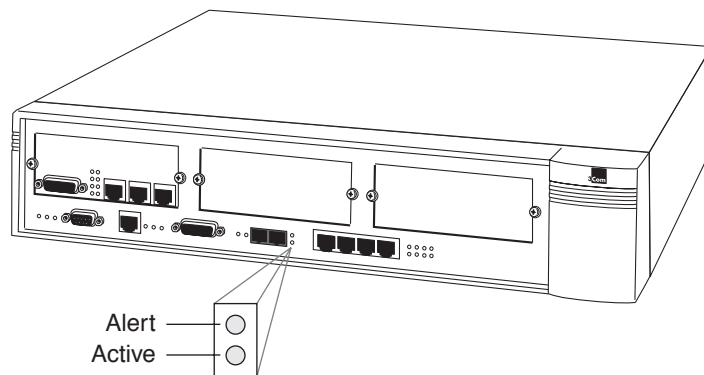

Connecting to the CBR Module

The CBR module provides an RJ48 DSX interface for T1-DSX/E1 traffic. Line Build Outs (LBOs) to DSX of up to 655 feet are supported. You must configure the LBOs in the CBR DSX Configuration Menu. See “Configuring the CBR Module” in Chapter 4, for details. You can typically make local connections to DTE equipment without DSU/CSUs, as long as the equipment supports a direct T1-DSX/E1 interface and can recover a T1-DSX/E1 signal. Table 19 lists the CBR T1-DSX/E1 pinouts.

Table 19 CBR T1-DSX/E1 Pinouts

PIN 1	RX (ring)
PIN 2	RX (tip)
PIN 3	NC
PIN 4	TX (ring)
PIN 5	TX (tip)
PIN 6	NC
PIN 7	NC
PIN 8	NC



If you are using a G703 coax physical connection to connect the E1 line to the interface, you must use the E1 Balun Adapter (part number 3C63904).

The serial port of the PathBuilder S330/S310 CBR module has two types of interface: V.35 for video data and RS-366 for video dial. These interfaces are broken out from a 50-pin connector on the S330/S310 via a Y cable. Use the V.35/RS-366 serial CBR connector to connect directly to H.320 video codec devices such as PictureTel, Vtel, and CLI.

Table 20 lists the CBR V.35/RS-366 Y cable pinouts.

Table 20 CBR V.35/RS-366 Connector Pinouts

Connector type at end of V.35/RS-366 cable	DB-25 subminiature, female for DCE	
Connector pinouts	<u>From</u>	<u>To</u>
Frame Ground	J1-46	J2-A
Circuit Ground	J1-45	J2-B
RTS	J1-35	J2-C
CTS	J1-42	J2-D
DSR	J1-43	J2-E
DCD	J1-44	J2-F
DTR	J1-34	J2-H
LL	J1-33	J2-K
SD+	J1-28	J2-P
SD-	J1-27	J2-S
RD+	J1-18	J2-R
RD-	J1-17	J2-T
SCTE+	J1-26	J2-U
SCTE-	J1-25	J2-W
SCR+	J1-22	J2-V
SCR-	J1-21	J2-X
SCT+	J1-20	J2-Y
SCT-	J1-19	J2-AA
366_RI	J1-50	J2-J
366_PWI	J1-29	J3-6
366_ACR	J1-31	J3-3
366_PND	J1-32	J3-5
366_DSC	J1-36	J3-13
366_DLO	J1-37	J3-22
366_NB1	J1-38	J3-14
366_NB2	J1-39	J3-15
366_NB4	J1-40	J3-16
366_NB8	J1-41	J3-17
366_CRQ	J1-47	J3-4
366_DPR	J1-59	J3-2
Signal Ground	J1-56	J3-7
SHT GRP 1	J1-49 J1-48	2
SHT GRP 2	J1-50 J1-51	2
SHT GRP 3	J1-53 J1-54 J1-55 J1-56	2

CBR Module LEDs The CBR module features the following front panel indicators:

Inservice (green)—Powers up in the “off” state and illuminates when you set the administrative status of the T1-DSX/E1 or serial port to *In Service*. See “Configuring the CBR Module” in Chapter 4 for details about how to set the administrative status of the ports on the CBR module.

ALARM (red)—Powers up in the “off” state and illuminates when an alarm condition is detected on the corresponding T1-DSX/E1 or V.35 line.

Figure 25 PathBuilder S330 CBR Module LEDs

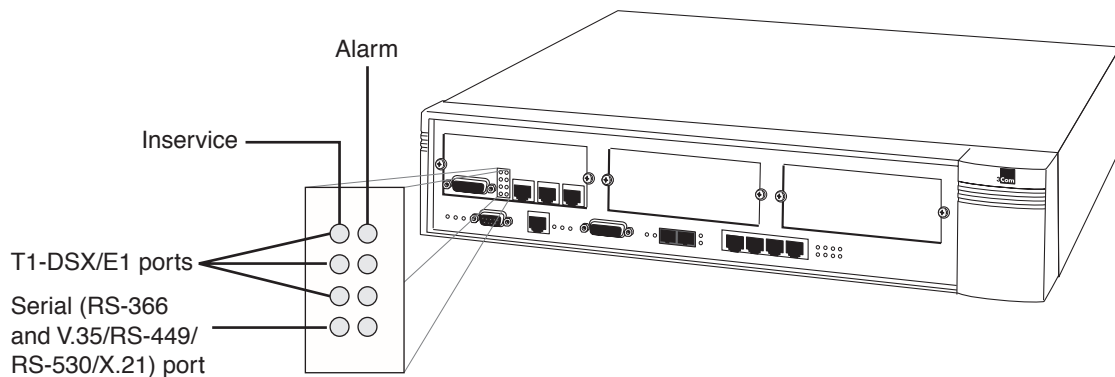

Connecting to the Voice Compression Module

The Voice Compression module provides an RJ48 DSX interface for T1-DSX/E1 traffic. Line Build Outs (LBOs) to DSX of up to 655 feet are supported. You must configure the LBOs in the VCM Port Configuration Menu. See “Configuring the Voice Compression Module” in Chapter 4, for details. You can typically make local connections to DTE equipment without DSU/CSUs, as long as the equipment supports a direct T1-DSX/E1 interface and can recover a T1-DSX/E1 signal. Table 21 lists the VCM T1-DSX pinouts.

Table 21 VCM T1-DSX/E1 Pinouts

PIN 1	RX (ring)
PIN 2	RX (tip)
PIN 3	NC
PIN 4	TX (ring)
PIN 5	TX (tip)
PIN 6	NC
PIN 7	NC
PIN 8	NC



If you are using a G703 coax physical connection to connect the E1 line to the interface, you must use the E1 Balun Adapter (part number 3C63904).

The Voice Compression module features the following front panel indicators, as illustrated in Figure 26:

PWR—Illuminates when the VCM is receiving power.

FAIL—Illuminates when the VCM card fails.

TEST—Illuminates during powerup, as internal diagnostics are being performed and during loopbacks.

STS 0 (Status 0)—Blinks green during normal operation.

STS 1 (Status 1)—Illuminates when the VCM port is in service.

INS—Illuminates when the VCM card is in service.

ALM—Illuminates when there is an alarm present on the VCM card.

Figure 26 Voice Compression Module LEDs

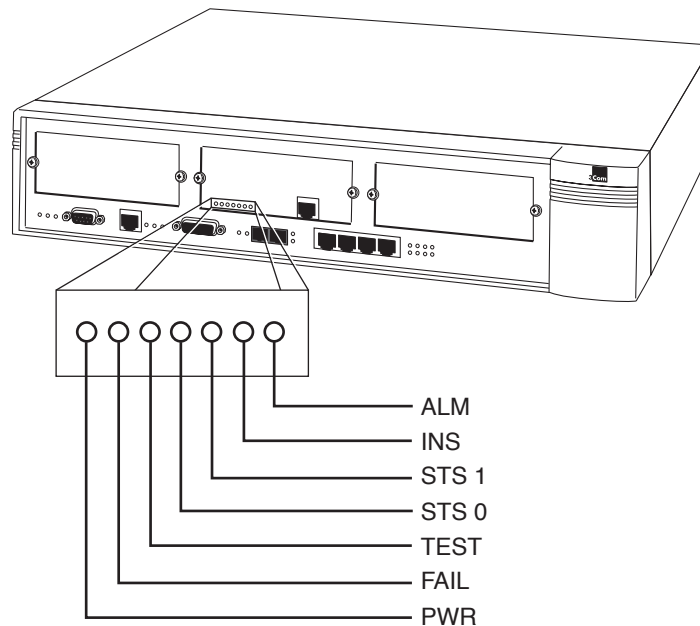

Connecting to the DS3/E3 Module

S330 only

Connect the DS3/E3 module to a DS3 repeater using the female BNC connectors. The maximum coax run is 450 feet. The transmitter in the DS3 UNI Module includes selectable LBO (Line Build-Out) to adjust the output signal to cable runs of 0-255 or 225-450 feet. Select the LBO during card configuration from the local terminal or NMS. See "Configuring the DS3/E3 UNI Module", in Chapter 4 for details.

The DS3/E3 UNI module features the following front panel indicators, as illustrated in Figure 27:

INS—Illuminates when the DS3/E3 card is in service.

ALM—Illuminates when an alarm is present on the DS3 card.

LOS (RED)—Powers up in the "off" state and illuminates when a LOS (Loss of Signal) condition is detected on the incoming DS3. The LOS LED is off if a signal is present. It reflects the LOS state of the DS3 in real time (no integration of the state is needed).

LOF (RED)—Powers up in the “off” state and illuminates when a LOF (Loss of Frame) condition is detected on the incoming DS3. The LOF LED is off when the signal is in frame. It reflects the LOF state of the DS3 in real time (no integration of the state is needed).

LOCD (RED)—Powers up in the “off” state and illuminates when a LOCD (Loss of Cell Delineation) condition is detected on the incoming DS3 under HEC (Header Error Control) framing. The LOCD LED is off when delineations are obtained. It reflects the LOCD state of the DS3 in real time (no integration of the state is needed).

Figure 27 DS3 UNI Module LEDs

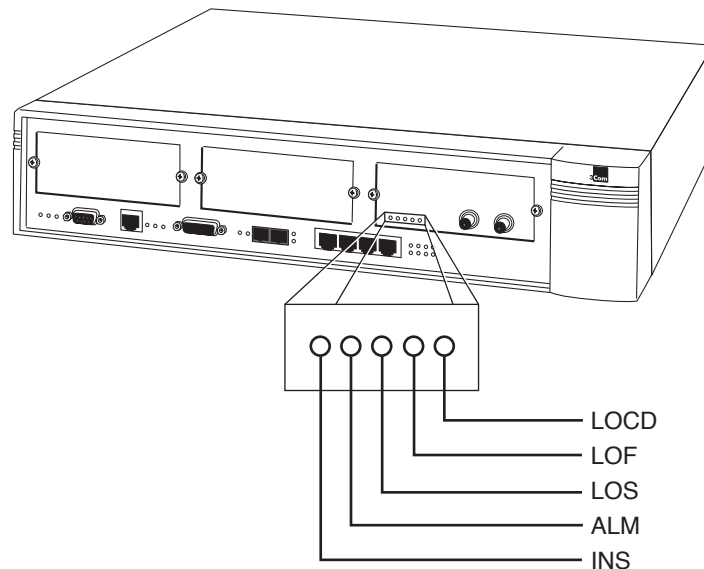

The DS3/E3 UNI shares the same queue (Queue 1) as the Group 1 IMA UNI; therefore, if a DS3/E3 expansion card is installed in slot 9, the system deletes Group 1 and all corresponding VCs on startup and generates an information only alarm. Furthermore, you cannot add Group 1 if a DS3/E3 expansion card is installed—either in the chassis or in the database. If you change the card type for slot 9 to DS3/E3 via the List Card menu, Group 1 and the corresponding VCs are not deleted until the system is restarted.

Step 5: Connect the Management Terminal

In order to configure application connections and an IP address for SNMP support, you must connect a management terminal to the PathBuilder S330/S310. To do this, follow these steps:

- 1 Connect a VT 100 terminal to the RS-232 (console) port on the front of the PathBuilder S330/S310.
- 2 Use the VT100 terminal to input an IP address for the PathBuilder S330/S310. See “Setting up Communication Parameters” in Chapter 3 for details.
- 3 Establish communication between the PathBuilder S330/S310 and any management terminal in one of these ways:
 - Direct RS-232 using the VT100 terminal or VT100 emulator, as described above
 - Direct 10BaseT on the Management CPU card using an IP Telnet session

Figure 28 illustrates the network management station terminal connection options.

Figure 28 Network Management Station Terminal Connection Options

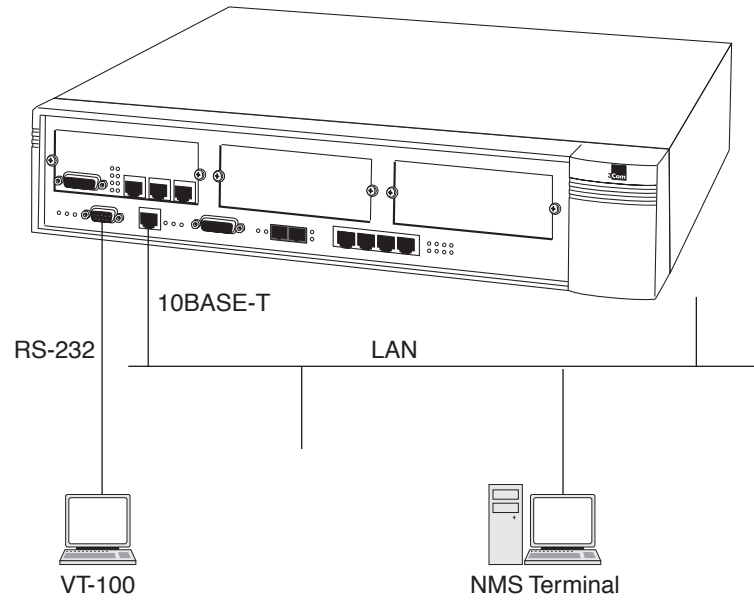

3

GETTING STARTED

This chapter tells you how to initialize and prepare SuperStack® II PathBuilder® S330 and SuperStack® II PathBuilder® S310 WAN access switches (PathBuilder S330/S310) for operation and how to use the PathBuilder S330/S310 menus. It contains the following sections:

- Logging On
- Using the Menu
- Performing Initial System Configuration
- Performing Additional Super User Functions
- Configuring In-band Management

Logging On

You enter initial configuration information via the local user interface. This interface is presented on a VT100 terminal connected to the RS-232 (console) port on the front of the PathBuilder S330/S310, as shown in Figure 29. See Chapter 2 for details about connecting the VT100 terminal.

Set the terminal for the following:

- 9600 baud
- no parity
- 8 data bits
- 1 stop bit

Figure 29 NMS Terminal Connection Options

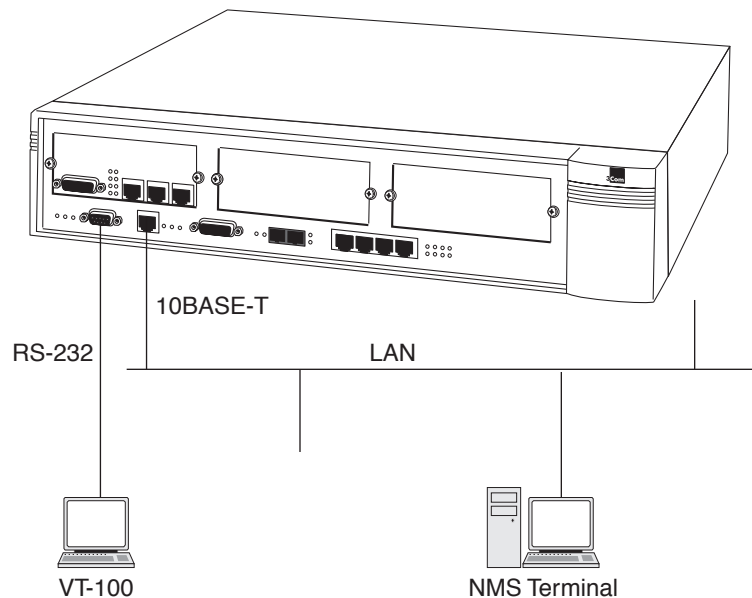

Use the options on the Main menu as follows:

- Select [1] *System Administration* to access common parameters.
- Select [2] *Configuration Management* to view or set configuration parameters for cards, ports, PVCs, video dialup, and other hardware and software features.
- Select [3] *Fault Management* to view or acknowledge alarms and set loopbacks.
- Select [4] *Performance Management* to view statistical data.
- Select [5] *Exit* to log out.

Using the Menus

The title of the menu or display appears at the top of the screen. Your access status appears in the upper righthand corner.

- *Read-Write* means that you have Read-Write control of the PathBuilder S330/S310 and can make changes to the system.
- *Read Only* means that you can only monitor the menus and displays.



Only one Read/Write session is allowed at any given time. The first session is the Read/Write session. Subsequent simultaneous sessions are Read Only.

Navigating through the Menus

You select a menu option by typing the selection number and pressing [Enter].

Displays that contain information and no selections include the prompt:

Press Esc for previous menu

Multi-page displays also prompt you to press "N" for the next page or "P" for the previous page.

Only the Main menu contains the Exit selection to log out. Selecting Exit returns you to the title screen with the password prompt. All other menus have a Previous menu selection which returns you to the Main menu one screen at a time. You can also press [Esc] to move back one menu at a time.

The auto logout feature automatically logs you out and returns you to the title screen if you do not press a key for a specified time (1 - 99 minutes). To set the autolog timeout, select [1] *System Administration* from the Main menu, then select [1] *General System Information*, then select [6] *Set Auto Logout Time*.



Always return to the Main Menu to log out or let the auto logout time expire. Exiting the program in any other way, such as turning power off to the network management station, may cause unpredictable results.

Understanding the Menu Hierarchy

The PathBuilder S330/S310 menu hierarchy includes several layers of menus. Each submenu has a name that is the same or similar to the name of the option that displays it. For example, selecting [2] *Configuration Management* on the Main Menu displays a submenu titled Configuration Management, and selecting [4] *Manage System Clock* from the System Administration menu displays a submenu titled System Clock Configuration. You can then select options on the submenus to display additional submenus or prompts that allow you to set various parameters.

Using the Menus to Change Settings

Settings are displayed in prompts at the bottom of the menus. For example, if you select

- [2] Configuration Management
- [1] Manage Card
- [4] OC3/STM-1 UNI
- [3] Set ATM Payload Scramble

The following prompt appears at the bottom of the SONET/STM-1 UNI Configuration menu:

Enter ATM Payload Scramble (1=No,2=Yes):

When you type a selection number and press [Enter], payload scrambling is disabled or enabled and the prompt is cleared.

Alarm Indicator

If the PathBuilder S330/S310 detects an alarm condition, an alarm indicator (the highlighted word "Alarm") appears to the left of the access status on every menu and display, as shown in Figure 32.

Figure 32 Alarm Indicator

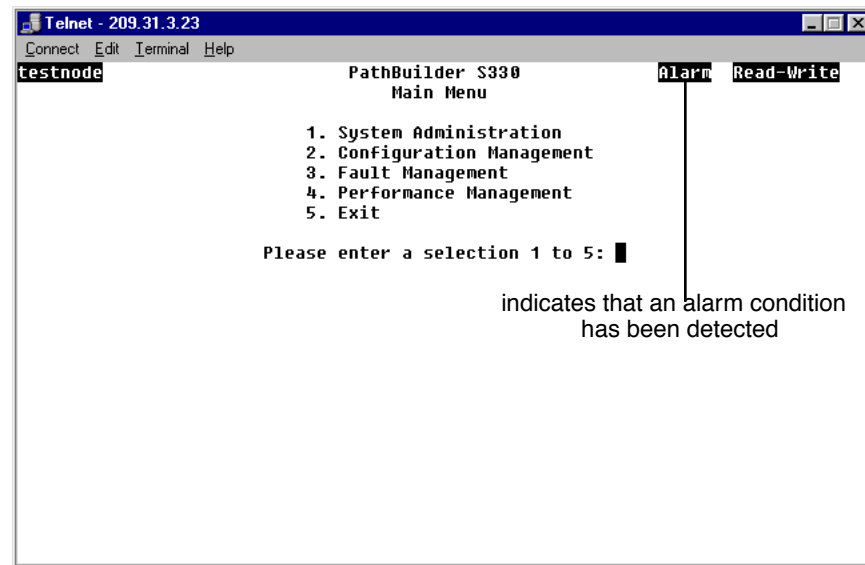

After you acknowledge the alarm, the alarm indicator is no longer highlighted, but the word "Alarm" remains in the upper right corner of the screen to indicate that an alarm has been acknowledged.

When the alarm is acknowledged and the condition that caused the alarm is cleared, the indicator disappears entirely. If a menu indicates that an alarm has been acknowledged and a new alarm occurs, the Alarm indicator is highlighted again.

See "Managing System Alarms" in Chapter 5, for instructions on acknowledging alarms.

Performing Initial System Configuration

After you install the PathBuilder S330/S310 hardware, you must complete the following three steps in order to put the unit into operation:

- 1 Configure the system clock
- 2 Set up communication parameters
- 3 Set the time and date
- 4 Set up passwords

You access the menus used to perform these steps from the System Administration menu, shown in Figure 33. To display the System Administration menu:

From the Main menu, select *[1] System Administration*.

Figure 33 System Administration Menu

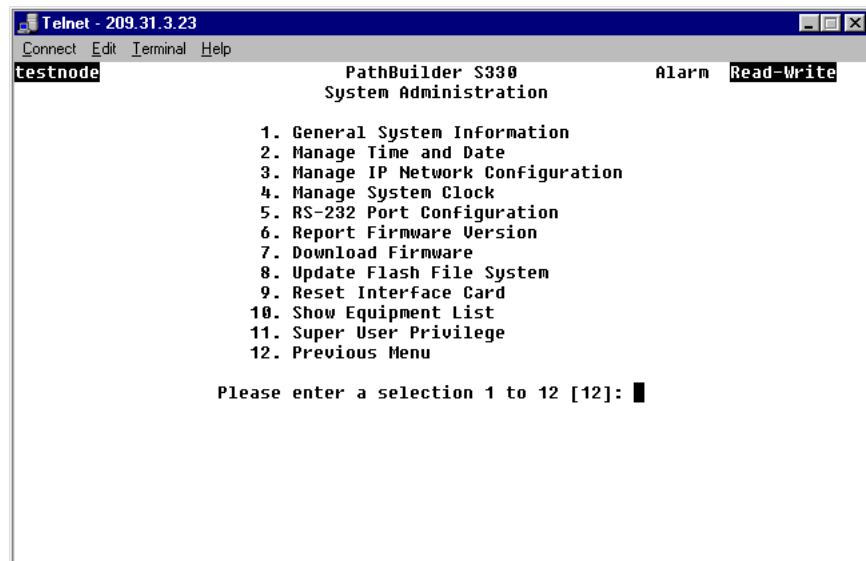

The following subsections provide instructions for performing the four initial configuration steps. See Chapter 4 for instructions on configuring specific PathBuilder S330/S310 ports and modules.

Configuring the System Clock

By default, the PathBuilder S330/S310 uses the internal clock as its reference clock. You can specify up to eight additional clocks for the system to use as a reference clock. When you set the clocks, you also assign each one a priority. You can then set the system clock to the clock with the highest priority. If this clock fails, the system automatically uses the clock with the next highest priority as its reference clock. It defaults to the internal clock only if all eight clocks fail or if there are no more valid selections.

To set system clocks, follow these steps:

- 1 From the System Administration menu, select [4] *Manage System Clock* to display the System Clock Configuration menu, shown in Figure 34.

Figure 34 System Clock Configuration Menu

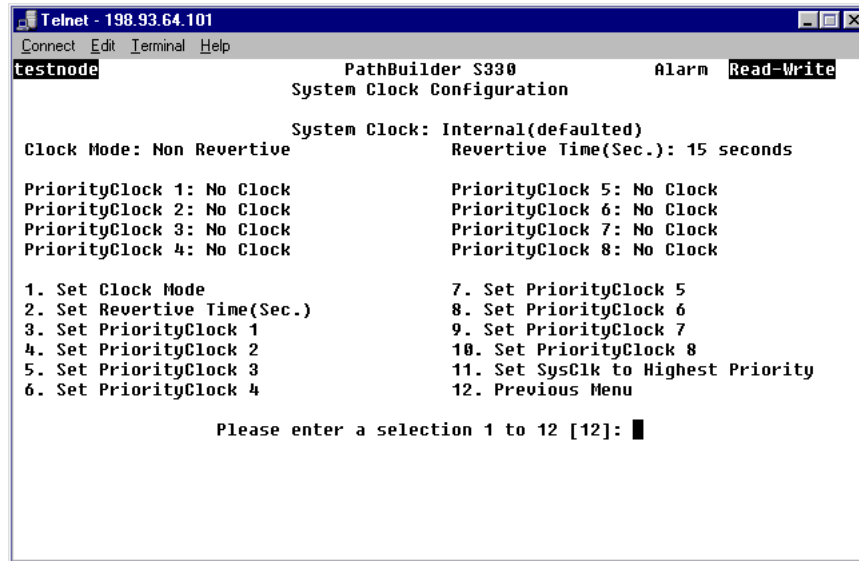

- 2 Select [3] *Set PriorityClock 1* to specify the clock which you want to designate as the priority 1 (highest priority) clock.
- 3 Enter the option number corresponding to the clock you want to designate as the priority 1 system clock. The clock options correspond to the available ports.



If you are configuring a PathBuilder S310, do not select unavailable ports (ports 2-4, CBR ports 2 and 3, and OC3/STM-1) as system clocks—even though the software lists these ports and allows you to select them.

- 4 Repeat steps 2 and 3 to designate up to seven additional clocks as the priority 2 through 8 clocks, substituting the appropriate option in step 2. For example, to designate the priority 2 clock, select [4] *Set PriorityClock 2*.
- 5 Select [11] *Set System Clock to Highest PriorityClock* to set the system clock to the clock you designated as the priority 1 clock in step 3 above. If this clock fails, the PathBuilder S330/S310 will automatically use the clock with the next highest priority as its reference clock.

Setting up Communication Parameters

In order for the PathBuilder S330/S310 to communicate to the Ethernet network, you must set the correct communication parameters. To do this, select [3] *Manage IP Network Configuration* From the System Administration menu, to display the Manage IP Network Configuration menu, shown in Figure 35, and configure the following:

- Local host IP address
- Trap client
- Default gateway

The subsections following the figure describe how to set these parameters.

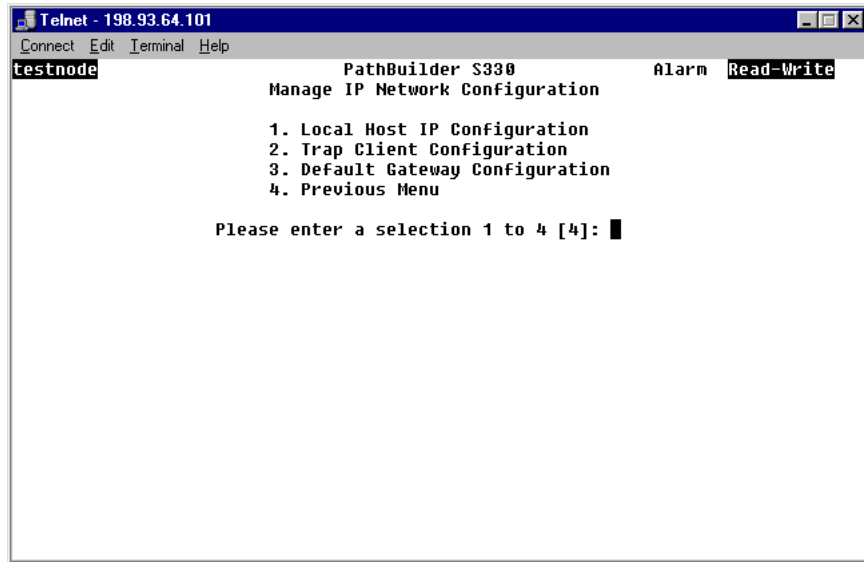
Figure 35 Manage IP Network Configuration Menu

Configuring the Local Host IP Address

In order for the PathBuilder S330/S310 to communicate on the network, you must use the VT100 terminal to assign an IP address to the device. Once you have entered the IP address for the PathBuilder S330/S310 on the VT100 terminal, you can continue configuring the device on the local console, or you can use a Telnet session to configure the device on a TCP/IP workstation.

To enter an IP address for the PathBuilder S330/S310, follow these steps:

- 1 From the Manage IP Network Configuration menu, select [1] *Local Host IP Configuration* to display the Local Host IP Configuration menu, shown in Figure 36.

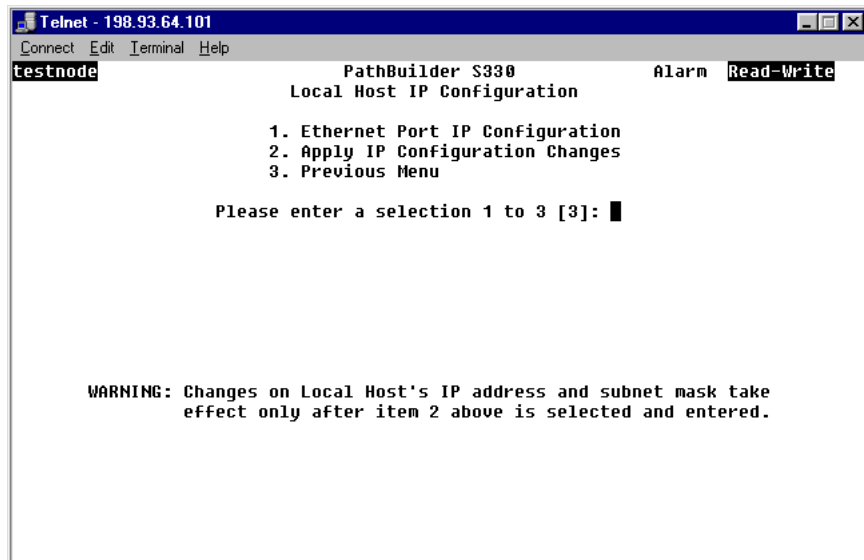

When you apply a change to this menu, you might get logged out if you are using a Telnet session. The default VT100 configuration is Baud rate: 9600, Parity: none, Data Bits:8, StopBits:1.

Figure 36 Local Host IP Configuration Menu

- 2 Select [1] *Ethernet Port IP Configuration* to display the Ethernet Port IP Configuration menu, shown in Figure 37.

Figure 37 Ethernet Port IP Configuration Menu

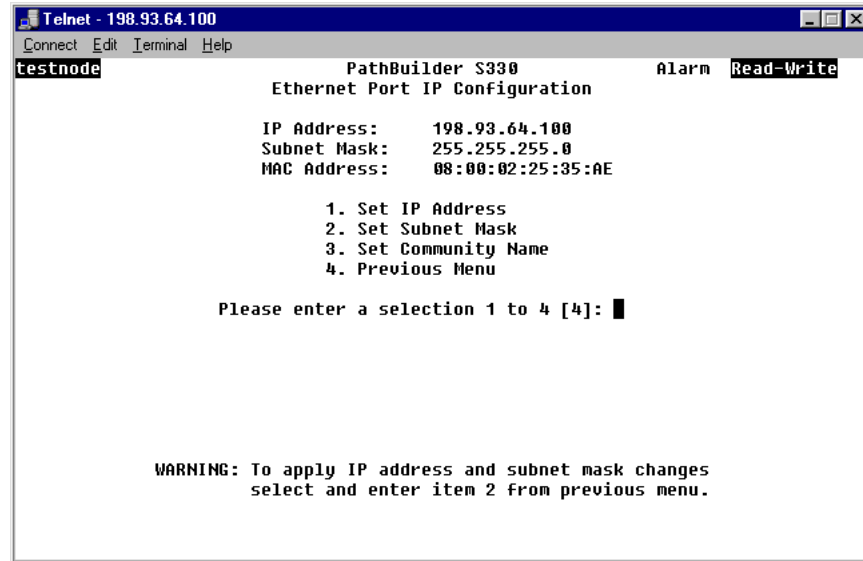

- 3 Enter the following information (by selecting the appropriate options and responding to the prompts that appear at the bottom of the screen) to enable IP Ethernet connectors:

IP Address—Provided by the network administrator. This is the IP address of the PathBuilder S330/S310 Management CPU.



You should consult the network administrator to obtain an IP Address for the PathBuilder S330/S310 which will allow its 10BaseT Management port to co-exist with hosts on its local LAN.

Subnet Mask—Provided by the network administrator.

Community Name—Enter **private** (The community name applies to the SNMP SET operation.)

Figure 38 shows a sample PathBuilder S330/S310 IP host setup.

Figure 38 Sample PathBuilder S330/S310 IP Host Setup

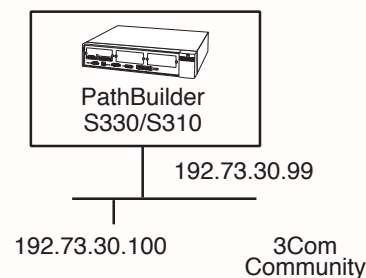

- 4 Select [4] *Previous menu* to return to the Local Host IP Configuration menu.
- 5 Select [2] *Apply IP Configuration Changes* to activate the IP address.



The IP address does not take effect until you apply your changes by selecting [2] Apply IP Configuration Changes from the Local Host IP Configuration menu (step 5 above).

Configuring Trap Clients

Trap clients are the network management stations to which you want the PathBuilder S330/S310 to send traps. You can specify up to four trap clients. To configure trap clients, follow these steps:

- 1 From the Manage IP Network Configuration menu, select [2] *Trap Client Configuration* to display the Trap Client Configuration menu, shown in Figure 39.

Figure 39 Trap Client Configuration Menu

```
Telnet - 198.93.64.101
Connect Edit Terminal Help
testnode
PathBuilder S330 Alarm Read-Write
Trap Client Configuration
1. Trap Client 1 Configuration
2. Trap Client 2 Configuration
3. Trap Client 3 Configuration
4. Trap Client 4 Configuration
5. Previous Menu
Please enter a selection 1 to 5 [5]:
```

- 2 Select the number corresponding to the trap client you want to configure. Figure 40 shows the menu for configuring trap client 1.

Figure 40 Trap Client 1 Configuration Menu

```
Telnet - 198.93.64.101
Connect Edit Terminal Help
testnode
PathBuilder S330 Alarm Read-Write
Trap Client 1 Configuration
IP Address: 0.0.0.0
Subnet Mask: 0.0.0.0
Port Number: 162
1. Set IP Address
2. Set Subnet Mask
3. Set Port Number
4. Previous Menu
Please enter a selection 1 to 4 [4]:
```

- 3 Enter the following information (by selecting the appropriate options and responding to the prompts that appear at the bottom of the screen) to configure the trap client:
 - IP Address**—The IP address of the network management station to which you want the PathBuilder S330/S310 to send traps.
 - Subnet Mask**—The subnet mask for the network management station to which you want the PathBuilder S330/S310 to send traps.
 - Port Number**—The system-defined port number. You should not modify this number. (SNMP/UDP).
- 4 Select [4] *Previous Menu* to return to the Trap Client Configuration menu.
- 5 Select [5] *Previous Menu* to return to the Manage IP Network Configuration menu.

Configuring the Default Gateway

The default gateway routes IP data to non-local networks (Telnet sessions from different subnetworks). To configure the default gateway, follow these steps:

- 1 From the Manage IP Network Configuration menu, select [3] *Default Gateway Configuration* to display the Default Gateway Configuration menu, shown in Figure 41.
- 2 Enter the following information (by selecting the appropriate options and responding to the prompts that appear at the bottom of the screen) to configure the default gateway:

IP Address—The IP address of the router which you want to configure as the default gateway.

Subnet Mask—The subnet mask for the router which you want to configure as the default gateway.

Figure 41 Default Gateway Configuration Menu

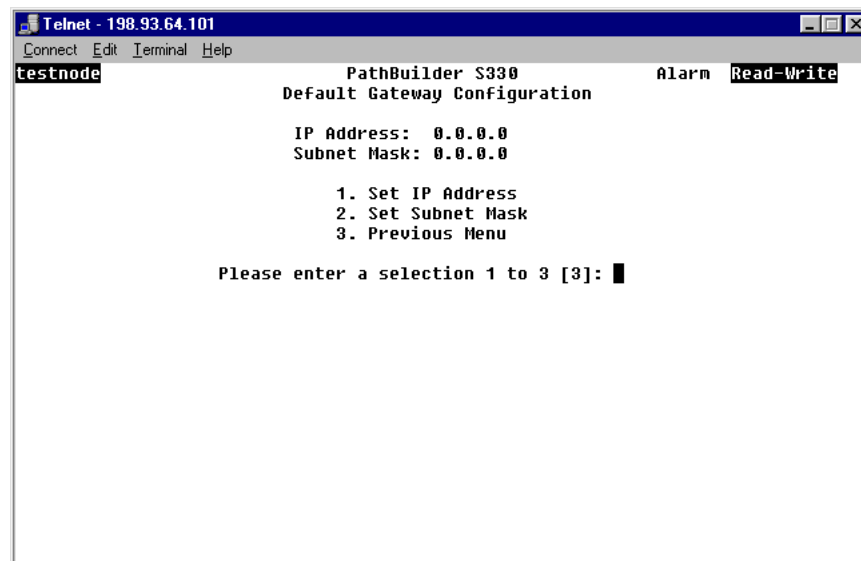

- 3 Select [3] *Previous Menu* to return to the Manage IP Network Configuration menu.
- 4 Select [4] *Previous Menu* to return to the System Administration menu.

Setting the Time and Date

To set the time and date, follow these steps:



It is important to set the time and date accurately because these settings provide the timestamp for alarms.

- 1 From the System Administration menu, select [2] *Manage Time and Date* to display the Time and Date Configuration menu, shown in Figure 42.

Figure 42 Time and Date Configuration Menu

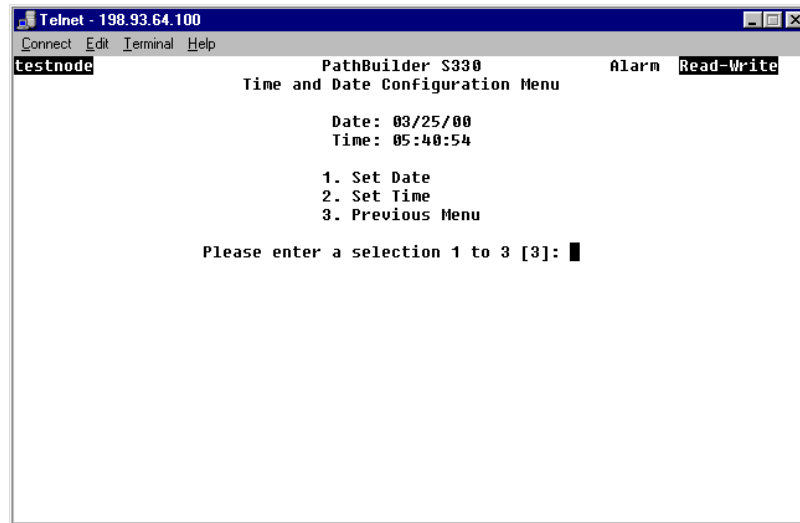

- 2 Select [1] *Set Date*. The following prompt appears at the bottom of the screen:
Enter Date (mm/dd/yy)
- 3 Enter the date.
- 4 Select [2] *Set Time*. The following prompt appears at the bottom of the screen:
Enter Time (hh:mm:ss):
- 5 Enter the time.
- 6 Select [3] *Previous Menu* to return to the System Administration menu.
- 7 Select [11] *Previous Menu* to return to the Main menu.

Setting up Passwords

The PathBuilder S330/S310 supports a total of up to 10 logins at the following three access levels:

Read-Only User—Can view information and configuration settings in the PathBuilder S330/S310 interface, but cannot set parameters or make any changes.

Read-Write User—Can view and set/change configuration information.

Super User—Can view and set/change configuration information and can perform the following super user functions:

- Set passwords
- Take over a read-write session
- Erase the system database

This section tells you how to set passwords. For details about how to take over read-write sessions and how to erase the system database, see “Performing Additional Super User Functions” later in this chapter.

The default password for all three access levels is **password**. This password logs you on initially as a super user. For security reasons, you should change the Super User, Read-Write, and Read-Only passwords as soon as possible.

To set the Super User, Read-Write, or Read-Only password, follow these steps:

- 1 From the System Administration menu, select [13] *Super User Privilege* to open the Super User Privilege menu, shown Figure 43.

Figure 43 Super User Privilege Menu

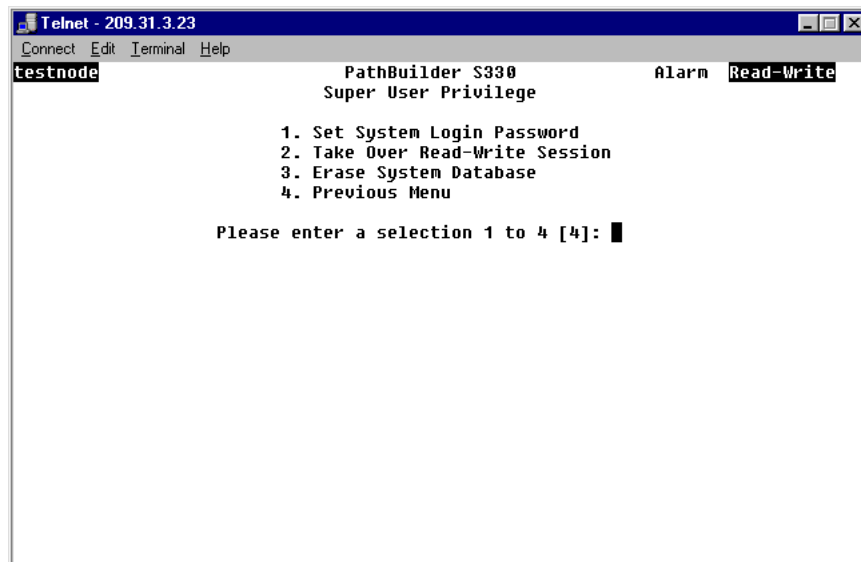

- 2 Select [1] *Set System Login Password* to open the System Login Password menu, shown in Figure 44.

Figure 44 System Login Password Menu

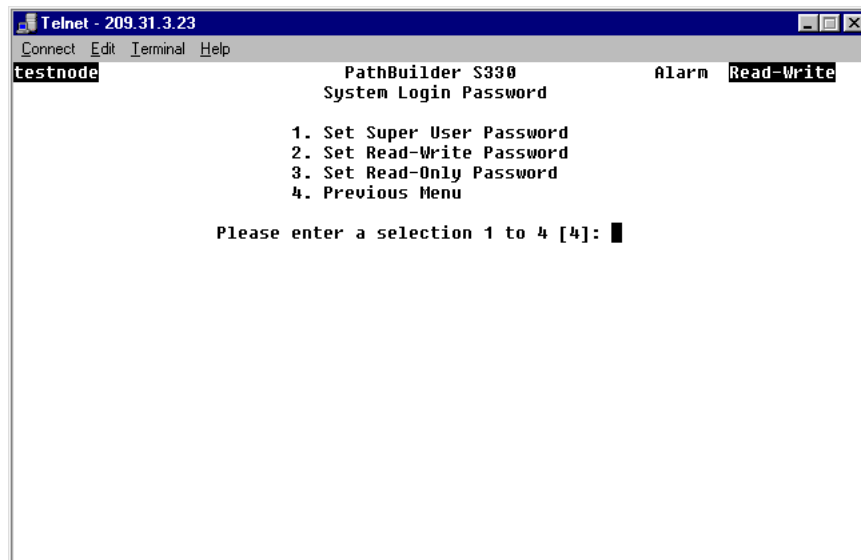

- 3 Select [1] *Set Super User Password*, [2] *Set Read-Write Password*, or [3] *Set Read-Only Password* to set the desired password.

The following prompt appears at the bottom of the screen:

Enter New Password:

- 4 Enter the new password. The password appears as asterisks on the screen as you enter it.



CAUTION: *Be sure to record your new password and keep the record in a safe place. If you forget your password and have no record of it, you can contact 3Com for assistance, but we may need to delete your database in order to solve the problem.*

The following prompt appears:

Re-enter New Password:

- 5 Re-enter the password you entered in step 4.
A message appears, indicating that the password has been saved.
- 6 Select [4] *Previous Menu* to return to the Super User Privilege menu.

Performing Additional Super User Functions

In addition to setting passwords, you can also take over read-write sessions and erase the system database from the Super User Privilege menu, shown earlier in Figure 43.

Taking over a Read-Write Session

The PathBuilder S330S310 allows only one read-write session at a time. If you have super user privileges, however, you can take over a read-write session without logging off. When you take over a read-write session, the previous read-write session is forced to a read-only session.

To take over a read-write session, follow these steps:

- 1 From the Super User Privilege menu, shown earlier in Figure 43 select [2] *Take Over Read-Write Session*.

The following prompt appears:

Do you want to take over read-write session (Y/N) [N]?

- 2 Enter **y** to take over the read-write session.

The following message appears:

The current session has been changed to Read-Write!
Press any key to return.

- 3 Press any key to resume your session in read-write mode.



The interface for the user whose read-write session you took over will switch to read-only mode the next time that user changes screens.

Erasing the System Database

In certain situations—if anomalous behavior on the part of the PathBuilder S330/S310 makes you suspect that the database has been corrupted, or if you have moved a unit from a different location, for example—you may want to consider erasing the system database and starting from scratch. You must have super user privileges in order to erase the system database.

To erase the system database, follow these steps:



CAUTION: Before you erase the system database, make a record of all configuration settings; these settings will be lost when you erase the database. Also keep in mind that erasing the database is an action that cannot be undone. Perform the following procedure only if you are sure that erasing the database is your best course of action.

- 1 From the Super User Privilege menu, shown earlier in Figure 43, select [3] *Erase System Database* to open the Erase System Database menu. This menu displays the following warning and prompt:

This action will cause a SOFT RESET of the system.
Do you want to erase the system database (Y/N) [N]?

- 2 Enter **y** to erase the system database.

Configuring In-band Management

In addition to managing the PathBuilder S330/S310 out-of-band, you can also manage the unit in-band via the 10Base-T port on the near-end MCPU card (up to ten VCs maximum).



For detailed instructions on configuring PVCs, see “Configuring Virtual Circuits” in Chapter 4.

To configure in-band management via the 10Base-T port on the near-end MCPU card, follow these steps:



If you use this method, you must use a new subnet with each PathBuilder S330/S310 and a new static route for each new subnet on the management station or router. You are also limited to managing ten remote units from the central management unit,

- 1 Open the Add Virtual Circuit menu and set preliminary circuit configuration parameters.
 - a From the Main Menu select [2] *Configuration Management* to open up the Configuration Management Menu.
 - b Select [2] *Manage Circuit*. This opens the Virtual Circuit Menu.
 - c Select [2] *Add Virtual Circuit*.
 - d Enter the desired description for the circuit, and press [Enter].
 - e Enter **1** to set the *VC Class* as *PVC*.
 - f Enter **1** to set the *VC Type* as *VCC*.
- 2 Build a PVC on the near-end PathBuilder S330/S310, using the MCPU as side A of the virtual circuit. To do this, you need to set the following side A parameters on the Add Virtual Circuit screen, as shown in Figure 45.
 - **Shaper Number**—Choose the number corresponding to the desired shaper value. You assign the shaper number from the MCPU Shapers screen. See “Configuring MCPU Shapers” in Chapter 4, for details.
 - **IP Address**—This address must be different than the local host IP address.
 - **Subnet Mask**—Specify any acceptable address (for example, 255.255.255.0)

Figure 45 Add Virtual Circuit Menu

```

Telnet - 198.93.64.100
Connect Edit Terminal Help
testnode PathBuilder S330 Alarm Read-Write
Add Virtual Circuit

Circuit Type: Unicast,UCC Description: testcircuit3
Admin. Status: 2(in service)
SIDE A SIDE B
Slot/Port/Card: 1/MCPU Slot/Port/Card: 4/OC3 UNI
Shaper Number: 1(56K/784K) Receive UPI/UCI: 0/2
IP Address: 234.56.78.9 Transmit UPI/UCI: 0/2
Subnet Mask: 222.33.44.5 Priority: 3
Priority: 1 Early Packet Discard: 1(no)
Early Packet Discard: 1(no)

Enter Admin. Status (1=out of service, 2=in service [2]): █

Early Packet Discard accepted.

```

- 3 Build a PVC on the far-end PathBuilder S330/S310, using the MCPU as side A of the circuit. Set the following parameters on the Add Virtual Circuit screen:
 - **Shaper Number**—Choose the number corresponding to the desired shaper value. You assign the shaper number from the MCPU Shapers screen. See “Configuring MCPU Shapers” in Chapter 4, for details.
 - **IP Address**—You must use a different subnet than the one you used for the near-end PathBuilder S330/S310.
 - **Subnet Mask**—Specify any acceptable address (for example, 255.255.255.0)
 - **VPI/VCI**—You must use the same values as you did for the near-end PathBuilder S330/S310.
 - 4 On the Manage IP Network Configuration menu, select [3] *Default Gateway Configuration* and set the following:
 - a Set the default gateway on the far-end PathBuilder S330/S310 to the PVC IP address you set for the near-end PathBuilder S330/S310 in step 1.
 - b Set the default gateway on the management station to the local host IP address of the near-end PathBuilder S330/S310.
-  For details about setting the default gateway, see “Configuring the Default Gateway” earlier in this chapter.
- 5 Apply your IP configuration changes.
 - a From the main menu, select [1] *System Administration*.
 - b From the System Administration menu, select [3] *Manage IP Network Configuration*.
 - c From the Manage IP Network Configuration menu, select [1] *Local Host IP Configuration*.
 - d From the Local Host IP Configuration menu, select [2] *Apply IP Configuration Changes*.

4

CONFIGURING PATHBUILDER S330/S310 MODULES, PORTS, AND APPLICATIONS

This chapter tells you how to configure the SuperStack® II PathBuilder® S330 and SuperStack® II PathBuilder® S310 WAN access switches' (PathBuilder S330/S310) CPU, modules, ports, and related applications so that the devices can pass traffic. It contains the following sections:

- Viewing and Configuring System Information
- Using the Configuration Management Menu
- Using the List Card Menu
- Configuring the Management CPU
- Configuring the CTX
- Configuring Ports
- Configuring the T1/E1 Interface
- Configuring the OC3/STM-1 Port
- Configuring the DS3/E3 UNI Module
- Configuring the Serial Interface
- Configuring the Ethernet Interface
- Configuring the CBR Module
- Configuring the Voice Compression Module
- Configuring Virtual Circuits
- Managing the Video Dial Feature

Viewing and Configuring System Information

The System Administration menu, shown in Figure 46, includes options that allow you to view and configure system information. In addition to using this menu for initial configuration, as described in Chapter 3, you can:

- Specify general system information.
- View system parameters for the RS-232 port.
- View the current firmware version.
- Download new firmware.
- Update the flash file system.
- Reset the interface card.
- View an equipment list.

The following subsections describe these System Administration menu options. See Chapter 3 for information about the options related to initial configuration: configuring the system clock, setting communication parameters, setting the time and date, and changing the default password.

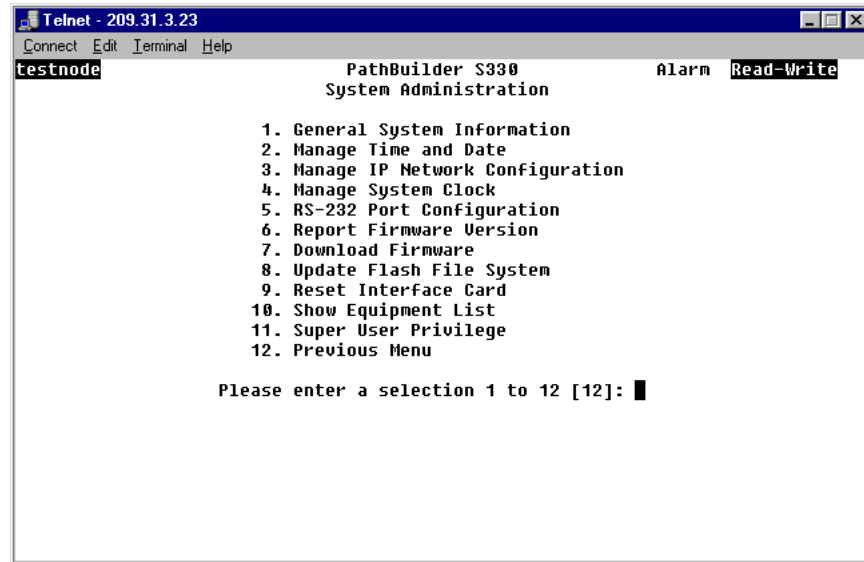
Figure 46 System Administration Menu

Specifying General System Information

General system information includes the following:

- Shelf name
- Customer name
- Phone number
- Maintenance contact
- Location
- Auto logout time

To specify or change general system information, follow these steps:

- 1** From the System Administration menu, select *[1] General System Information* to display the General System Information menu shown in Figure 47. This menu displays the current system information and provides options that allow you to change the current settings.
- 2** Select the option corresponding to the setting you want to change. A prompt appears at the bottom of the screen.
- 3** Enter the new setting.
- 4** Repeat steps 2 and 3 for any other settings you want to change.
- 5** Select *[8] Previous Menu* to return to the System Administration menu.

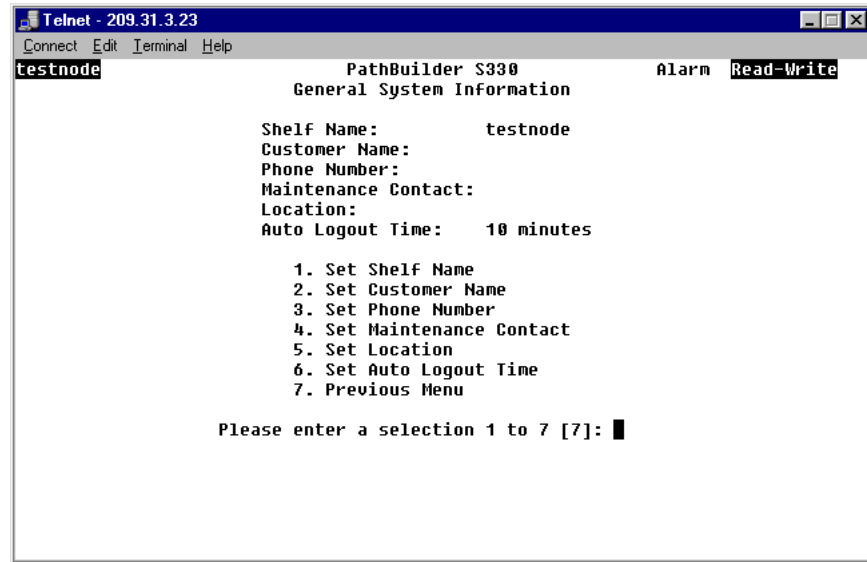
Figure 47 Specifying General System Information

Viewing RS-232 Port Configuration Information

You enter initial configuration information using the VT100 terminal connected to the PathBuilder S330/S310's RS-232 port. See "Logging On" in Chapter 3, for details. To view the terminal configuration:

From the System Administration menu, select *[5] RS-232 Port Configuration*.

Viewing the Firmware Version

To view the version number for the firmware that is currently running on the CPU:

From the System Administration menu, select *[6] Report Firmware Version* to open the Report Firmware Version screen, shown in Figure 48.

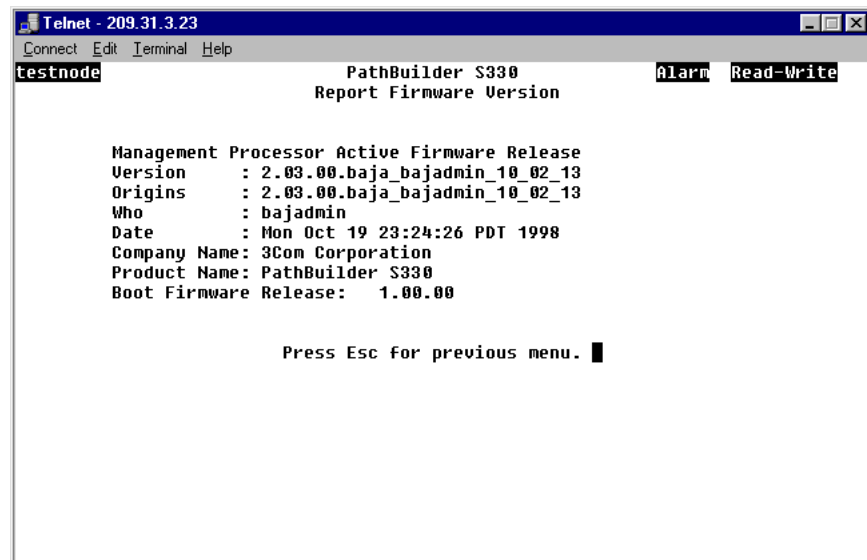
Figure 48 Report Firmware Version Screen

The Report Firmware Version screen displays the following information about the management processor active firmware (the upgradeable firmware currently being used by the MCU):

Version—The released firmware version number. This is the version number that is displayed on the login screen.

Origins—The original engineering build number for the release.



If the Version and Origins release numbers are the same, then the release is not an official release but rather a Beta test version.

Who—The user login ID for this software build.

Date—The date and time that the build was made.

Company Name—3Com Corporation (or OEM partner if desired)

Product Name—The PathBuilder product for which this image was built: *PathBuilder S700, PathBuilder S600, PathBuilder S330, or PathBuilder S310.*

In addition to the management processor firmware information listed above, the Report Firmware Version screen also lists the *Boot Firmware Release*—the version number of the boot firmware containing the bootstrap code used to bring up the operation firmware.)

Downloading New Management Processor Firmware

The PathBuilder S330/S310 module retains the operation firmware in a flash memory bank located in the motherboard. On power-up or reset, the code image is copied from the flash memory to the main memory.

The flash memory retains a copy of the operation firmware and can be upgraded using TFTP or the Xmodem protocol. TFTP is used if you are attached over the Ethernet interface through a Telnet session. Xmodem is used if you are attached to serial port 1 on a VT100 terminal.



We recommend that you avoid using the serial interfaces unless the Ethernet interface is unavailable, as a download could take 30 minutes at 9600 baud using the serial interfaces.

When downloading, the flash memory is overwritten with the new code. Once the firmware is successfully downloaded, a system reset brings up the new code.



The following instructions pertain to UNIX environments. You can also download firmware from a PC: from a TFTP application, configure for binary mode, specify the location of the image files, and use the PUT command.

Downloading via the Ethernet Port

To download new firmware using TFTP, via the Ethernet port, follow these steps:



Be sure to log in via Telnet. If you log in at a serial port, the download sequence will attempt an Xmodem rather than a TFTP download.

- 1 Obtain the correct image file location and name from 3Com Customer Service.
- 2 Telnet into the PathBuilder S330/S310 unit.
- 3 From the System Administration menu, select [7] *Download Firmware*. The following prompt appears:

```
This action will erase the flash memory
Do you want to download firmware (Y/N) [N]?
```

- 4 Enter **y** and wait for the **Ready to download...** message.
- 5 From a workstation or PC (typically the same one doing the Telnet), invoke TFTP using the PathBuilder S330/S310 IP address. From TFTP do:

```
binary
put image.abs
```

where **image.abs** is the filename of the image file to download)

The download will complete in about two minutes (over lightly loaded Ethernet). The TFTP should indicate that the file is transferred, and the Telnet screen should display "download complete."

Downloading via the Serial Port

To download new firmware using the Xmodem protocol, via the serial port, follow these steps:



You must use a terminal emulation program that supports Xmodem protocol.

- 1 Obtain the correct image file location and name from 3Com Customer Service.
- 2 Log into the PathBuilder S330/S310 unit through a serial port.
- 3 From the System Administration menu, select [7] *Download Firmware*. The following prompt appears:

```
This action will erase the flash memory
Do you want to download firmware (Y/N) [N]?
```

- 4 Enter **y**. The PathBuilder S330/S310 unit assumes that an Xmodem download is to be done and looks for that protocol over the serial port. Once the unit has erased the flash memory, a message on the screen indicates that the unit is ready to accept an Xmodem download.
- 5 On the terminal emulation prompt, select Xmodem protocol and input the file name of the binary file to be downloaded.



The typical download time at 9600 baud is greater than 30 minutes.

Updating the Flash File System

The flash file system contains system configuration information which is automatically saved in flash memory at a predetermined interval. To update the flash file system immediately, rather than at the next scheduled interval, follow these steps:

- 1 From the System Administration menu, select [8] *Update Flash File System*. The following prompt appears:

Do you want to update the flash file system (Y/N) [N]?

- 2 Enter **y** to update the flash file system.



CAUTION: *The user configuration data is automatically saved into flash memory every minute. If there is a system failure (for example, a power failure), any changes that you make during the auto-saving interval will be lost. Thus, we recommend that you use the [8] Update Flash File System option, as described above, immediately after you make major configuration changes.*

Resetting the Interface Card

The PathBuilder S330/S310 software allows you to reset only the MCPU interface card and the Voice Compression module (VCM) card. Resetting the MCPU reboots the system. To reset the MCPU interface card or the VCM card, follow these steps:



If you reset the MCPU interface card, you will terminate your Telnet session.

- 1 From the System Administration menu, select [9] *Reset Interface Card*. You are prompted to select the card you want to reset.
- 2 Enter the option corresponding to the card you want to reset (MCPU or VCM). The following prompt appears:

Are you sure you want to reset this card (Y/N) [N]?

- 3 Enter **y** to reset the selected card.

Viewing an Equipment List

To view information about the modules currently installed on your PathBuilder S330/S310:

From the System Administration menu, select [10] *Show Equipment List*. Figure 49 shows a representative Equipment List.

Figure 49 Equipment List

SLOT	CARD-TYPE	PART#-idprom	PART#-oem	SERIAL#	REV#
0	Shelf	030-11970-0001	030-11970-0001	BEAC002371	AA
1	MCPU	030-11970-0001	030-11970-0001	BEAC002371	AA
2	CTX	030-11970-0001	030-11970-0001	BEAC002371	AA
3	DS1 UNI (4)	030-11970-0001	030-11970-0001	BEAC002371	AA
4	OC3 UNI	030-11970-0001	030-11970-0001	BEAC002371	AA
5	SIM	030-11970-0001	030-11970-0001	BEAC002371	AA
6	ETHERNET	030-11970-0001	030-11970-0001	BEAC002371	AA
7	CBR-E1(3)/U35	030-11755-0001	030-11755-0001	BEBC001002	AAcksum err
8	VOICE COMP (DSX)				

Press any key to previous menu.

The Equipment List displays the following information for each installed module:

Slot—Slot number. This is a reference number for the ports on the motherboard. This number corresponds to the number on the List Card menu. (See Figure 51, later in this chapter.)

Card type—The card type: Shelf, MCPU, CTX, T1/E1 UNI (4), OC3/STM-1 UNI, SIM, Ethernet, or CBR T-1DSX, or CBR E1.

PART#-idprom—The part number as programmed at the factory.

PART#-oem—The part number for OEM customers.

Serial #—The serial number for the card. This is the same for all ports on the motherboard. The optional CBR module has a separate serial number.

Rev #—The revision number for the card. This is the same for all ports on the motherboard, as they come already installed in the unit. The optional CBR module has a separate revision number.

Using the Configuration Management Menu

Select [2] *Configuration Management* from the Main menu to display the Configuration Management menu, shown in Figure 50. Use this menu to access submenus and screens that allow you to:

- **Manage cards**—View shelf configuration information and configure the PathBuilder S330/S310 CPU, CTX, ports, CBR module, and Voice Compression module.
- **Manage circuits**—List, add, modify, and delete virtual circuits.
- **Manage the bridge**—Set the bridge aging timer and configure the bridge.
- **Manage the video dial feature**—View the call routing table, manually start and end video dial-up sessions.

Figure 50 Configuration Management Menu

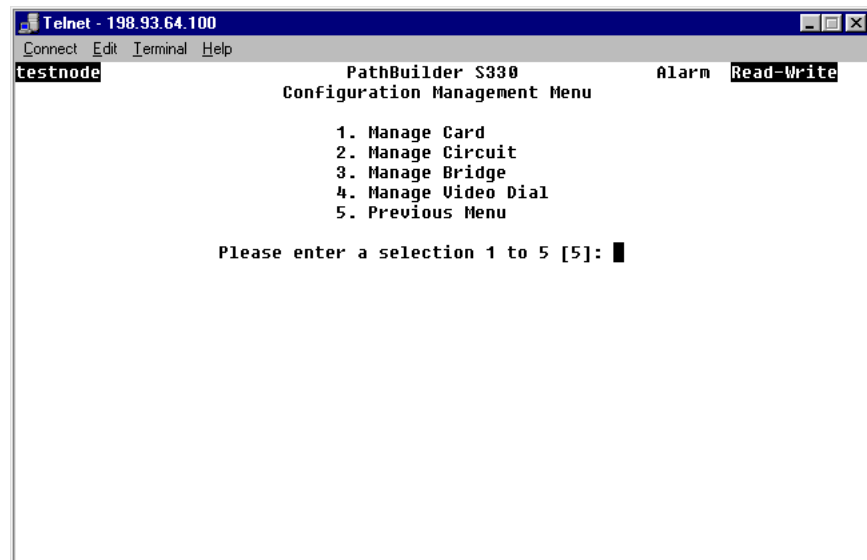

Using the List Card Menu

The List Card menu, shown in Figure 51, lists the shelf and all installed interfaces.

To display the List Card menu follow these steps:

- 1 From the Main menu select *[2] Configuration Management*.
- 2 From the Configuration Management menu, select *[1] Manage Card*.

Select *[0] Shelf* from the List Card menu to view configuration information for the shelf. The Shelf Configuration screen is a read-only screen that displays the *Hardware Revision* and *Serial Number*.

The remaining options (1 and above) on the List Card menu display menus that allow you to configure specific modules and ports. The following sections tell you how to perform the specific configurations available from the List Card menu.

Figure 51 List Card Menu

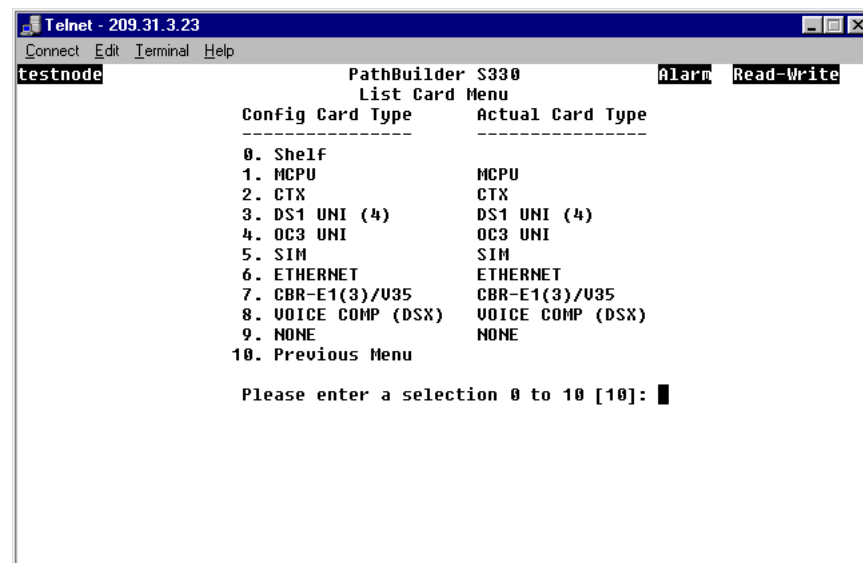

Configuring the Management CPU

MCPU configuration involves viewing configuration information and managing shapers. To display the MCPU Menu, follow these steps:

- 1 From the Configuration Management menu, select *[1] Manage Card* to display the List Card menu.
- 2 Select *[1] MCPU* to display the MCPU Configuration menu, shown in Figure 54.

From the MCPU Card menu, you access the submenus and screens from which you view configuration information and configure shapers, as described in the following subsections.

Figure 52 MCPU Configuration Menu

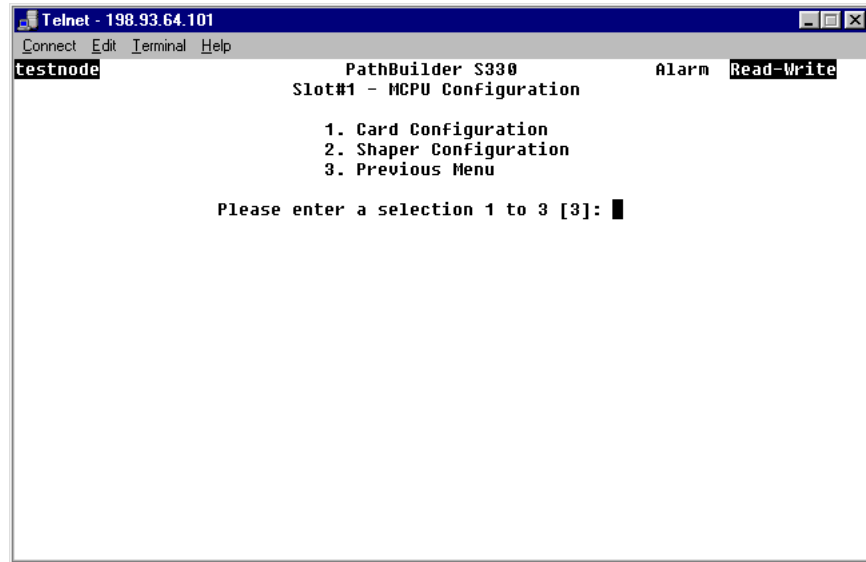

Viewing MCPU Configuration Information

To view configuration information for the management CPU:

From the MCPU Configuration menu, select *[1] Card Configuration* to open the Management Processor Configuration screen. This screen displays the following CPU configuration information:

- Hardware revision
- Serial number
- Status (In Service or Out of Service)

Configuring MCPU Shapers

The PathBuilder S330/S310 supports three MCPU shapers parameters:

- **Peak Cell Rate (PCR)**—The maximum rate that can be passed.
- **Sustained Cell Rate (SCR)**—The maximum average rate that a bursty, on-off traffic source can send; used in conjunction with maximum burst size.
- **Maximum Burst Size (MBS)**—The maximum number of cells that can be sent at the peak rate; used in conjunction with sustained cell rate.

Using the MCPU Shapers screen, shown below in Figure 53, you can configure up to 15 shapers. The values that you set for the shapers on this screen are the values that are then available for the Shaper Number parameter that you set when you configure certain types of virtual circuits. See “Common Virtual Circuit Parameters” later in this chapter for details.

How you configure the MCPU shapers depends on the type of service you have.

- If you have a peak rate service:
 - Set the peak rate at the maximum allowable value.
 - Set the sustained cell rate at the same rate as the peak rate.
- If you have a sustained rate service:
 - Set the peak rate at the line rate (for example 45Mbps for a DS3 line).
 - Set the sustained cell rate and maximum burst rate at the values given to you by your service provider.



CAUTION: When assigning shapers for VCM circuits, be sure that the shapers are wider than the bandwidth used for the voice traffic.

To configure the MCPU shapers, follow these steps:

- 1 From the MCPU Card menu, shown in Figure 52, select [2] Shaper Configuration to display the MCPU Shaper screen, shown in Figure 53.

The MCPU Shaper screen consists of a table listing the current shaper values in bits/second (bits for the maximum burst size shaper) and cells/second (cells for the maximum burst size shaper). Initially, the shapers are set to default values.

Figure 53 MCPU Shaper Screen

Shaper Number	SCR		PCR		MBS		Alarm	Read-Write
	bps	cps	bps	cps	bits	cells		
1	56000	132	784000	1849	424	1		
2	112000	264	784000	1849	424	1		
3	224000	528	784000	1849	424	1		
4	448000	1057	784000	1849	424	1		
5	673000	1588	784000	1849	424	1		
6	1351000	3187	1351000	3187	424	1		
7	1492000	3520	1538000	3628	424	1		
8	1538000	3628	1538000	3628	424	1		
9	1923000	4535	1923000	4535	424	1		
10	2380000	5615	2564000	6047	424	1		
11	4000000	9433	4000000	9433	424	1		
12	6060000	14293	6060000	14293	424	1		
13	8000000	18867	8000000	18867	424	1		
14	10000000	23584	10000000	23584	424	1		
15	16666000	39308	16666000	39308	424	1		

Use ARROW keys to navigate, ENTER to edit, ESC to go back, S to save changes

- 2 To enter a new shaper value, use the arrow keys on your keyboard to move to the cell in the shaper table that you want to change.
 - To set a new Sustainable Cell Rate or Peak Cell Rate shaper, enter the new value in the bits/second (bps) column. The system automatically calculates the cells/second (cps) based on the value you enter.
 - To set a new Maximum Burst Size shaper, enter the new value in the cells column. The system automatically calculates the bits based on the value you enter.

Configuring the CTX

CTX configuration involves managing buffers and managing shapers. To display the CTX Menu, follow these steps:

- 1 From the Configuration Management menu, in Figure 50, select [1] *Manage Card* to display the List Card menu, shown earlier in Figure 51.
- 2 Select [2] *CTX* to display the CTX menu, shown in Figure 54.

Figure 54 CTX Menu

```

Telnet - 198.93.64.101
Connect Edit Terminal Help
testnode PathBuilder S330 Alarm Read-Write
          CTX Menu
          1. Manage Shapers
          2. Manage Buffers
          3. Apply CTX Buffer Changes
          4. Show UC Statistics By Shaper
          5. Show UC Statistics By Buffer
          6. Previous Menu
          Please enter a selection 1 to 6 [6]:
  
```

From the CTX menu, you access the submenus and screens from which you perform buffer and shaper configuration, as described in the following subsections.

Configuring CTX Shapers

The PathBuilder S330/S310 supports ten peak rate shapers. The shapers are separated into ten virtual queue-trunks:

- 4 for the group 1 IMA WAN interface:
 - Trunk bulk
 - medium
 - low1
 - low2
- 2 for the AAL5 SAR (Ethernet and V.35/RS-449 packet)
 - SAR output
 - SAR input



CAUTION: *The default configuration is optimized for performance.*

- 4 for the OC3/STM-1 interface:
 - OC3/STM-1 bulk (MMF or SMF)
 - OC3/STM-1 queue 1
 - OC3/STM-1 queue 2
 - OC3/STM-1 queue 3
 - OC3/STM-1 queue 4

You can assign shapers for these queue-trunks based on peak rate (or bulk shaping) towards the WAN. To do this, follow these steps:

- 1 From the Configuration Management menu, select [1] *Manage Card* to display the List Card menu.
- 2 Select [2] *CTX* to display the CTX menu, shown in Figure 54.
- 3 From the CTX menu, select [1] *Manage Shapers*. The CTX Shapers menu appears, as shown in Figure 55.

Figure 55 CTX Shapers Menu

```

Telnet - 198.93.64.101
Connect Edit Terminal Help
testnode PathBuilder S330 Alarm Read-Write
          CTX Shapers

          Shaper          Cells/Second
1) Trunk Bulk          390.625K
2) Trk Grp 1 Q1        390.625K
3) Trk Grp 1 Q2        390.625K
4) Trk Grp 1 Q3        390.625K
5) SAR Output          78.125K
6) SAR Input           78.125K
7) OC3 Bulk            390.625K
8) OC3 Q1              390.625K
9) OC3 Q2              390.625K
10) OC3 Q3             390.625K

Enter Shaper# (1..10) or 11 for previous page[11]:

```

- 4 Select the number corresponding to the shaper you want to configure. A prompt appears similar to the following:

```
Enter cells/sec, (150..195 312K)
```

- 5 Enter the desired shaper value.

Configuring CTX Buffers

The CTX is an output-buffered switch, with a 64K cell buffer capacity. The software sets up a default configuration, but you can change it if you want. For example, you should make the queue (buffer) used for your router traffic as large as possible. To do this, you must first deallocate memory from another queue—OC3/STM-1 queue 3, for example—and reallocate the memory to the queue that will carry your router traffic. See “CTX Output Queues and Memory Partition” in Appendix B, for reference information pertaining to configuring the output buffers.

To change the default output buffer configuration, follow these steps:

- 1 From the Configuration Management menu, select [1] *Manage Card* to display the List Card menu.
- 2 Select [2] *CTX* to display the CTX menu, shown above in Figure 54.
- 3 From the CTX menu, select [2] *Manage Buffers*. The CTX Buffers menu, shown in Figure 56, appears.

Figure 56 CTX Buffers Menu

	Slot	Interface	Queue	Buffer	Cells	Cong On %	Cong Off %
1)	3	IMA Grp 1	0 (high)	768		75	50
2)	3	IMA Grp 1	1	768		75	50
3)	3	IMA Grp 1	2	768		75	50
4)	3	IMA Grp 1	3	19200		75	50
5)	3	IMA Grp 2	0 (high)	768		75	50
6)	3	IMA Grp 2	1	768		75	50
7)	3	IMA Grp 3	0 (high)	768		75	50
8)	3	IMA Grp 3	1	768		75	50
9)	3	IMA Grp 4	0 (high)	768		75	50
10)	3	IMA Grp 4	1	768		75	50
11)	4	OC3	0 (high)	768		75	50
12)	4	OC3	1	768		75	50
13)	4	OC3	2	768		75	50
14)	4	OC3	3	19200		75	50
15)		(SAR ports)	0 (high)	768		75	50
16)		(SAR ports)	1	6400		75	50
17)	7	(EXP7)	0 (high)	768		75	50
18)	7	(EXP7)	1	768		75	50
19)	8	(EXP8)	0 (high)	768		75	50
20)	8	(EXP8)	1	768		75	50

Enter Queue# (1..20) or 21 for previous page [21]: █

- Select the number corresponding to the queue for which you want to change the buffer size. The CTX Queue Buffer Configuration menu, shown in Figure 57, appears. This menu lists the current buffer configuration for the selected queue and provides options that allow you to change the buffer size and set congestion thresholds.

Figure 57 Configuring CTX Buffers and Congestion Thresholds

Interface: Slot 3: IMA Grp 1
Queue: 0 (high)
Buffer Size: 768
Congestion On: 75%
Congestion Off: 50%

1. Set Buffer Size
2. Set Congestion On
3. Set Congestion Off
4. Previous Menu

Please enter a selection 1 to 4 [4]: █

WARNING: Changes to CTX buffer configuration take effect only after item 3 of the CTX Menu (2 back) is selected and entered.

- Select [1] *Set Buffer Size*. The following prompt appears:
Enter Buffer Size (768..62580 cells):
- Enter the desired buffer size, in cells (256 cells = 1 block).
- Use the [2] *Set Congestion On* and/or [3] *Set Congestion Off* options to change the default congestion thresholds.

When you select one of these options, a prompt appears at the bottom of the screen, allowing you to enter a new threshold in the range 0% to 100%. When the buffer reaches the *Congestion On* threshold, the congestion filter is on. When the buffer falls below the *Congestion Off* threshold, the congestion filter is off.

For example, if you set *Congestion On* to 75% and *Congestion Off* to 50%, the congestion filter is on when the buffer is 75% full and is off when the buffer drops below 50% full.

See “Setting Congestion Thresholds” below for further details about congestion thresholds.



CAUTION: *You should enable early packet discard for AAL5 traffic only.*

- 8 Select [4] *Previous Menu* to return to the CTX Buffers menu.
- 9 Press [Esc] to return to the CTX menu.
- 10 Select [3] *Apply CTX Buffer Changes* to apply your settings.



CAUTION: *This operation will affect traffic.*

Setting Congestion Thresholds

For every connection where early packet discard is enabled, a status is kept when there is a partial packet for that connection in the queue. Once the queue cell level exceeds the *Congestion On* thresholds, only connections with partial packets already existing in the queue are allowed in. Cells from other connections are dropped. Once the congestion has subsided to the *Congestion Off* level, then all remaining connections are allowed.

Set the *Congestion On* threshold based on the maximum packet size expected and the number of active connections sending packets at a particular instant based on a probability model.

Set the *Congestion On* level to allow some hysteresis in the operation.

Configuring Ports

The PathBuilder S330/S310 ports each have an administrative and an operational status. To set up a virtual circuit, you must first set the administrative status of the port which will carry the circuit online to In Service. You can also configure other parameters, depending on the type of port.



When you set the administrative status to Out of Service, the operational status is set to Out of Service whether or not the port is actually operational or not. Once you set the administrative status to In Service (online), the operational status will indicate the true port status (Out of Service if there is a port failure, or In Service if not).

The following sections tell you how to configure specific ports on the PathBuilder S330/S310.

Configuring the T1/E1 Interface

Configuring the T1/E1 interface involves the following tasks:

- Configuring the four individual T1/E1 ports
- Setting up and configuring UNI and/or IMA groups (if desired)
- Viewing IMA link and group status
- Configuring the T1/E1 card



The PathBuilder S310 has only one T1/E1 port and does not support IMA groups.

Configuring the T1/E1 Ports

To configure the individual T1/E1 ports, follow these steps:

- 1 From the Configuration Management menu, select [1] *Manage Card* to display the List Card menu, shown earlier in Figure 54.
- 2 From the List Card menu, select [3] *DS1 UNI* to open the T1 (DS1) UNI or E1 UNI Configuration menu. Figure 58 shows the T1 (DS1) UNI Configuration menu. The E1 UNI Configuration menu is the same.

Figure 58 T1 (DS1) UNI Configuration Menu

```
Telnet - 198.93.64.100
Connect Edit Terminal Help
testnode
PathBuilder S330 Alarm Read-Write
Slot#3 DS1 UNI Configuration

1. Port Configuration
2. IMA Link Status
3. Group Configuration
4. IMA Group Status
5. Card Information
6. Previous Menu

Please enter a selection 1 to 6 [6]: █
```

- 3 Select [1] *Port Configuration* to open the T1 (DS1)/E1 UNI Port Configuration Selection menu. Figure 59 shows the T1 (DS1) UNI Port Selection menu. The E1 UNI Port Configuration menu is the same.

Figure 59 T1 (DS1) UNI Port Selection Menu

```

Telnet - 198.93.64.100
Connect Edit Terminal Help
testnode PathBuilder S330 Alarm Read-Write
Slot#3 DS1 UNI Port Configuration

1. Port 1
2. Port 2
3. Port 3
4. Port 4
5. Previous Menu

Please enter a selection 1 to 5 [5]:

```

- 4 Select the number corresponding to the T1/E1 port you want to configure to open the Port Configuration menu. Figure 60 shows a T1 (DS1) UNI Port Configuration menu. The E1 UNI Port Configuration menu is similar.

Figure 60 Configuring a T1/E1 Port

```

Telnet - 198.93.64.100
Connect Edit Terminal Help
testnode PathBuilder S330 Alarm Read-Write
Slot#3 Port#1 - DS1 UNI-CSU Configuration

Application: CSU          Group: 1
LBO: 0 dB                Admin. Status: Out of Service
Line Code: B8ZS          Operation Status: Out of Service
Framing: ESF             Inband Lpbk: Disabled
Timing: System
Gain Limit: 36 dB
AFA: No

1. Set Application        7. Set Admin. Status
2. Set LBO                8. Set Inband Lpbk
3. Set Framing           9. Previous Menu
4. Set Timing
5. Set Gain Limit
6. Set AFA

Please enter a selection 1 to 9 [9]:

```

The Port Configuration menu lists the current parameters for the selected T1/E1 port and provides options for changing the settings.

- 5 Change any of the following information (by selecting the appropriate options and responding to the prompts that appear at the bottom of the screen) to configure the selected T1/E1 port:

Application—The application:

CSU—straight T1, long haul (up to 2,000 feet)

DSX—short haul T1 (up to 655 feet)

LBO (T1 only)—Line Build Out. The setting for the transmit signal level: 0, 7.5, 15, or 22 db. The LBO compensates for the distance between the card and the CSU/repeater. It is a setting for the transmit signal level.

Framing—The type of frame organization configured for the T1/E1 port interface: *D4* or *ESF* for T1. For E1 *Framing* is a read-only parameters and is always set to *multi-frame*. Set this parameter to match the service provider or device connection framing.



CAUTION: A framing mismatch can cause LOF, OOF alarm conditions and result in traffic loss.

Timing (T1 only)—The type of input clock service configured for the T1 module. Set the timing source to system if you are using the T1 module as a trunk module.

System—Configures the T1 module to use the internal clock as the timing source.

Loop—Configures the T1 module to use the input port Rx clock as the timing source; timing is received from the service “loop.” Select Loop if the T1 UNI module is used for the network/carrier service termination, in which case the carrier (the service “loop”) typically provides the timing source.

Gain Limit (T1 only)—The setting for the receive signal level: 26 or 36 dB.

AFA—Enables (yes) or disables (no) Automatic Frequency Adjustment. AFA monitors the error rate detected by the CRC (cyclic redundancy check) error-checking scheme of each of the T1/E1 links (ports). It automatically disables and re-enables a port when the error rate on that port is at a set level for a set time.

Activation Rate—The CRC (cyclic redundancy check) BER (bit error rate) at which AFA takes a link out of service based on the Activation Min.: 10^{-4} , 10^{-5} , 10^{-6} , 10^{-7} . For further details about setting this parameter, see “Activation/Deactivation Bit Error Rates” below. This parameter appears only when AFA is enabled.

Activation Min.—The period during which AFA monitors the link condition prior to taking it out of service, in minutes: 1 to 15. This parameter appears only when AFA is enabled.

Deactivation Rate—The CRC (cyclic redundancy check) BER (bit error rate) at which AFA puts a link in service based on the Deactivation Min.: 10^{-4} , 10^{-5} , 10^{-6} , 10^{-7} . For further details about setting this parameter, see “Activation/Deactivation Bit Error Rates” below. This parameter appears only when AFA is enabled.

Deactivation Min.—The period during which AFA monitors the link condition prior to putting it in service, in minutes: 1 to 15. This parameter appears only when AFA is enabled.

Admin Status—Administrative status: *Out of Service* or *In Service*.

Inband Lpbk (T1 only)—Enables or disables inband loopback detection.

Activation/Deactivation Bit Error Rates

Table 22 translates bit errors rates into the total number of errors for various time periods. Use this table as a reference when you are selecting activation and deactivation bit error rates for the AFA feature.

Table 22 Bit Error Rates Translated into Total Number of Errors

Bit Error Rate (BER)	Total Errors in 1 second	Total Errors in 1 Minute	Total Errors in 2 Minutes	Total Errors in 5 Minutes	Total Errors in 15 Minutes
10 ⁻⁴	15	900	1800	4500	13500
10 ⁻⁵	1.5	90	180	450	1350
10 ⁻⁶	0.15	9	18	45	135
10 ⁻⁷	0.015	1	2	5	13

The T1 (DS1)/E1 UNI Configuration menu lists the following additional read-only parameters:

Group—The number of the group to which the ports belong.

Tx LID—Transmit link identification. This should match the Rx LID of the remote end IMA device. Tx LID is displayed only if the port is part of an IMA group.

Rx LID—Receive link identification. This should match the Tx LID of the remote end IMA device. Rx LID is displayed only if the port is part of an IMA group.

Operation Link Delay—Operation link delay synchronized, in msec. This is the actual link delay used to synchronize the IMA links. Operations LDS is displayed only if the port is part of an IMA group.

- 6 Select [9] *Previous Menu* to return to the T1/E1 UNI Configuration menu.
- 7 Repeat steps 3 and 4 for any other T1/E1 ports that you want to configure.

Configuring UNI and IMA Groups

You can map two to four T1/E1 ports into an IMA group, thereby creating a logical, inverse-multiplexed, high-speed link. The PathBuilder S330 also supports UNI groups.



The PathBuilder S310 features a single T1/E1 port and does not support IMA or UNI groups.



The DS3/E3 UNI shares the same queue (Queue 1) as the Group 1 IMA UNI; therefore, if a DS3/E3 expansion card is installed in slot 9, the system deletes Group 1 and all corresponding VCs on startup and generates an information only alarm. Furthermore, you cannot add Group 1 if a DS3/E3 expansion card is installed—either in the chassis or in the database. If you change the card type for slot 9 to DS3/E3 via the List Card menu, Group 1 and the corresponding VCs are not deleted until the system is restarted.

Adding UNI Groups

To set up a UNI group, follow these steps:

- 1 From the Configuration Management menu, select [1] *Manage Card* to display the List Card menu, shown earlier in Figure 51.
- 2 From the List Card menu, select [3] *DS1 UNI* to open the T1 (DS1) UNI or E1 UNI Configuration menu, shown earlier in Figure 58.
- 3 From the T1 (DS1) UNI or E1 UNI Configuration menu, select [3] *Group Configuration* to display the Group menu, shown in Figure 61.

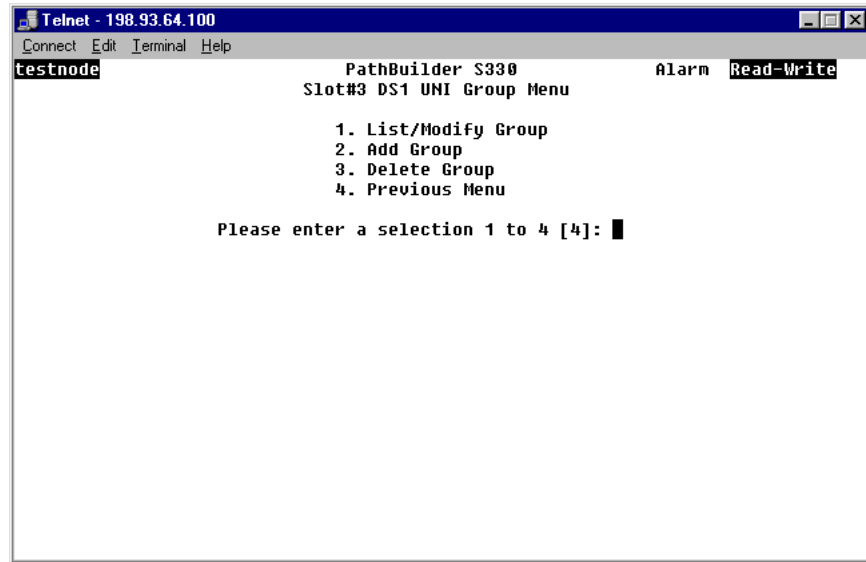
Figure 61 Group Menu

```
Telnet - 198.93.64.100
Connect Edit Terminal Help
testnode PathBuilder S330 Alarm Read-Write
Slot#3 DS1 UNI Group Menu

1. List/Modify Group
2. Add Group
3. Delete Group
4. Previous Menu

Please enter a selection 1 to 4 [4]: █
```

- 4 Select [2] *Add Group* to display the Add Group menu, shown in Figure 62.

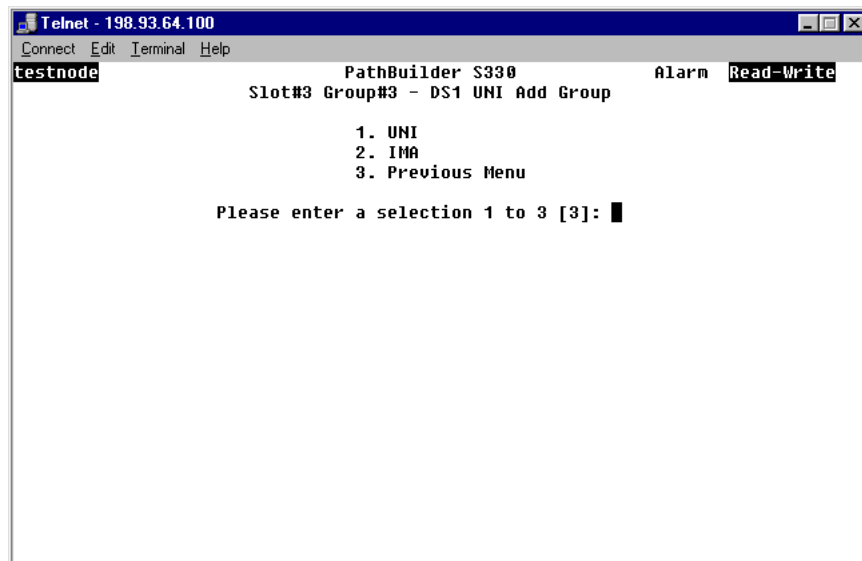
Figure 62 Add Group Menu (Selecting Group Type)

```
Telnet - 198.93.64.100
Connect Edit Terminal Help
testnode PathBuilder S330 Alarm Read-Write
Slot#3 Group#3 - DS1 UNI Add Group

1. UNI
2. IMA
3. Previous Menu

Please enter a selection 1 to 3 [3]: █
```

- 5 Select [1] *UNI*. The Add Group menu appears as shown in Figure 63.

Figure 63 Add Group Menu (Adding UNI Group)

```

Telnet - 198.93.64.100
Connect Edit Terminal Help
testnode PathBuilder S330 Alarm Read-Write
Slot#3 Group#3 - DS1 UNI Add Group

Admin. Port(s):
Operation Port(s):
Admin. Status: Out of Service
Operation status: Out of Service

1. Set Admin. Port(s)
2. Set Admin. Status
3. Previous Menu

Please enter a selection 1 to 3 [3]: █

```

- 6 Select *[1] Set Admin. Port(s)*. The following prompt appears at the bottom of the screen:
Enter Admin Port(s):
- 7 Enter the port numbers for the T1/E1 port you want to include in the UNI group.
- 8 Select *[2] Set Admin. Status* and enter **2** to put the group in service.
- 9 Select *[3] Previous Menu*.
- 10 If desired, repeat steps 5-8 to set up a second UNI group and put it into service.

Adding IMA Groups

- 1 From the Configuration Management menu, select *[1] Manage Card* to display the List Card menu, shown earlier in Figure 51.
- 2 From the List Card menu, select *[3] DS1 UNI* to open the T1 (DS1) UNI or E1 UNI Configuration menu, shown earlier in Figure 58.
- 3 From the T1 (DS1) UNI or E1 UNI Configuration menu, select *[3] Group Configuration* to display the Group menu, shown in Figure 64.

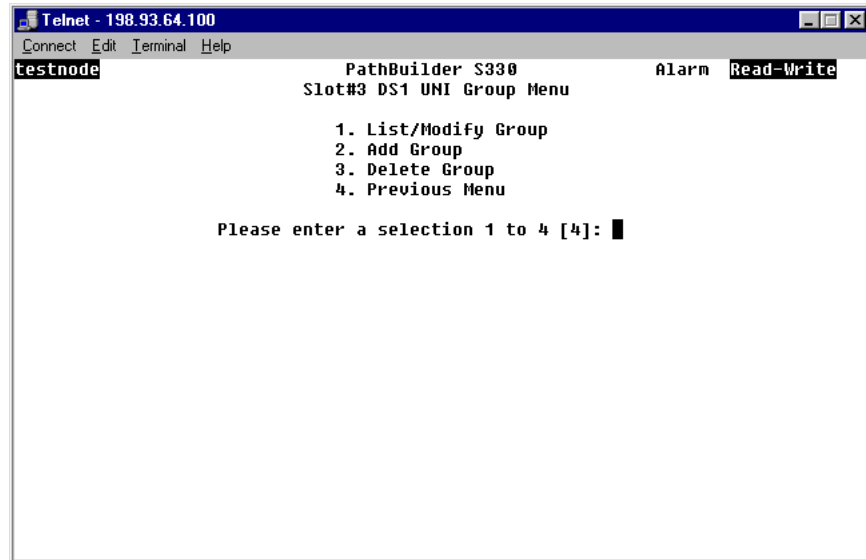
Figure 64 Group Menu

- 4 Select [2] *Add Group* to display the Add Group menu, shown in Figure 65.

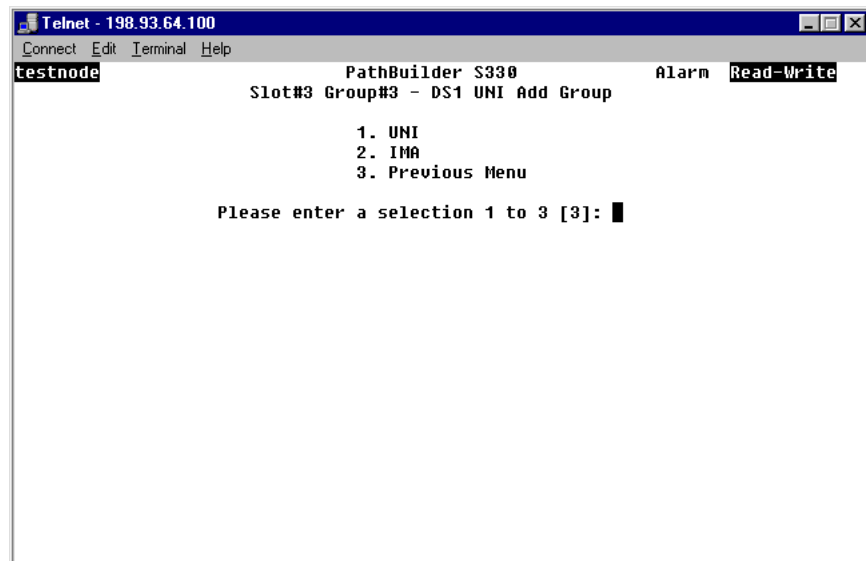
Figure 65 Add Group Menu (Selecting Group Type)

- 5 Select [2] *IMA*. The Add Group menu appears as shown in Figure 66.

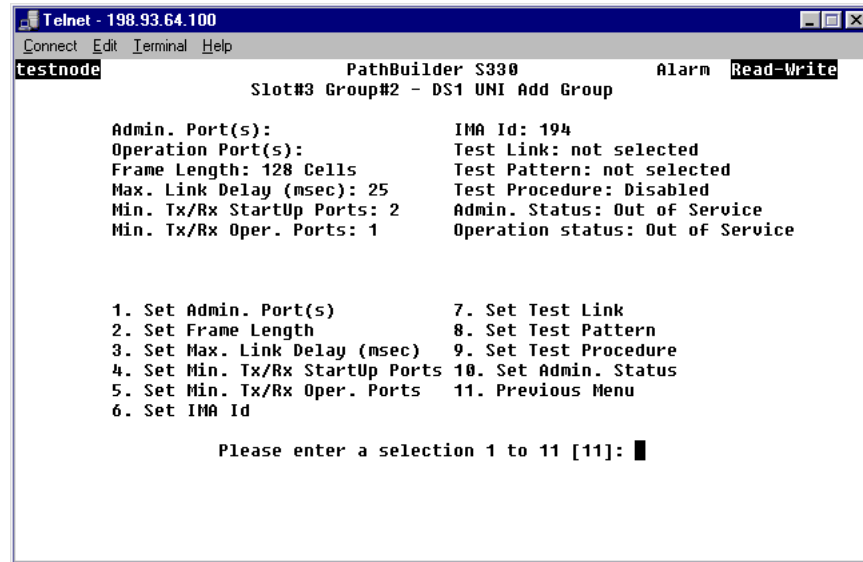
Figure 66 Add Group Menu (Adding IMA Group)

- 6 Select [1] *Set Admin. Port(s)*. The following prompt appears at the bottom of the screen:

Enter Admin Port(s) (1..4):

- 7 Enter the port numbers for the T1/E1 ports you want to include in the group. You can use a hyphen to indicate a range of ports. For example, to include ports 1-3 in a group you could enter **1-3**.
- 8 Specify any of the following information (by selecting the appropriate options and responding to the prompts that appear at the bottom of the screen) to configure the IMA group.

Frame Length—The frame length: 32, 64, 128, 256.

Max. Link Delay—The maximum link differential delay allowed in the group: 0 to 70 msec.

Min Tx/Rx Startup Ports—The minimum number of ports in the group that must be operational in order for the group to come up: 1 to n, where n is the number of ports in the group.

Min Tx/Rx Oper. Ports—The minimum number of ports in the group that must be operational in order for the group to come up and be operational: 1 to n, where n is the number of ports in the group.

IMA ID—A user-selected number to identify the IMA group.

Test Link—The port number of the link that is to perform the test procedure.

Test Pattern—The pattern to be looped back in the test procedure: 0-254.

Test Procedure—Enables or disables the test procedure. When the test procedure is enabled, the test pattern is sent out on the designated test link and then looped back on the other links in the group.

Admin Status—The administrative status of the group: *In Service* or *Out of Service*.

- 9 Select [11] *Previous Menu*.
- 10 If desired, repeat steps 5-8 to set up another IMA group.

Viewing and Modifying IMA and UNI Groups

Once you have added a group, you use the List/Modify Group menu to view and modify group configuration parameters.

To view and/or modify an existing group, follow these steps:

- 1 From the Group menu, shown in Figure 61, select [1] *List/Modify Group* to open the List/Modify Group Selection menu.
- 2 Enter the number corresponding to the group you want to view or modify to display the List/Modify Group menu for that group. Figure 67 shows the List/Modify Group menu for an IMA group. The List/Modify Group menu for a UNI group is similar, but it lists only the parameters you can set for UNI groups: *Admin Ports* and *Admin Status*.

Figure 67 Modifying an Existing IMA Group

```

Telnet - 198.93.64.100
Connect Edit Terminal Help
testnode PathBuilder S330 Alarm Read-Write
Slot#3 Group#2 - DS1 UNI List/Modify Group

Admin. Port(s): 2-4          IMA Id: 232
Operation Port(s):          Test Link: not selected
Frame Length: 128 Cells     Test Pattern: not selected
Max. Link Delay (msec): 25   Test Procedure: Disabled
Min. Tx/Rx StartUp Ports: 3  Admin. Status: Out of Service
Min. Tx/Rx Oper. Ports: 3    Operation status: Out of Service

1. Set Admin. Port(s)        7. Set Test Link
2. Set Frame Length          8. Set Test Pattern
3. Set Max. Link Delay (msec) 9. Set Test Procedure
4. Set Min. Tx/Rx StartUp Ports 10. Set Admin. Status
5. Set Min. Tx/Rx Oper. Ports 11. Previous Menu
6. Set IMA Id

Please enter a selection 1 to 11 [11]: █

```

- 3 If the Admin. Status of the group is In Service, select [10] *Set Admin. Status* and enter **1** to take the group out of service.



You must take the group out of service before you can modify it.

- 4 Change any of the group parameters as desired.

Deleting IMA and UNI Groups

To delete an existing IMA or UNI group, follow these steps:

- 1 From the Group menu, shown in Figure 61, select [3] *Delete Group* to open the Delete Group Selection menu.
- 2 Enter the number corresponding to the group you want to delete to open the Delete Group menu, shown in Figure 68. This menu lists the parameters for the selected group and warns you that deleting the group will delete any virtual circuits using that group.

Figure 68 Delete Group Menu

```

Telnet - 209.31.3.23
Connect Edit Terminal Help
testnode PathBuilder S330 Alarm Read-Write
Slot#3 Group#1 DS1 UNI Delete Group

Admin. Port(s): 1-4 IMA Id: 14
Operation Port(s): Test Link: not selected
Frame Length: 128 Cells Test Pattern: not selected
Max. Link Delay (msec): 25 Test Procedure: Disabled
Min. Tx StartUp Ports: 4 Admin. Status: Out of Service
Min. Rx StartUp Ports: 4 Operation status: Out of Service
Min. Tx Oper. Ports: 4
Min. Rx Oper. Ports: 4

Warning: This will delete 5 vc's using this group
Are you sure you want to delete Group# 1 ? (y/n, [n]): █

```

- 3 Enter **y** in response to the confirmation prompt to delete the group.



When you delete an IMA group, all the VCs using that group are also deleted.

Viewing IMA Link Status

To view IMA Link Status for a selected T1/E1 port, follow these steps:

- 1 From the Configuration Management menu, select **[1] Manage Card**.
- 2 From the List Card menu, select **[3] DS1 UNI** to open the T1 (DS1) UNI or E1 UNI Configuration menu, shown earlier in Figure 58.
- 3 Select **[2] IMA Link Status** to open the IMA Link Status menu, shown in Figure 69. The IMA Status menu lists only the ports that are members of an IMA group.

Figure 69 IMA Link Status Menu

```

Telnet - 198.93.64.100
Connect Edit Terminal Help
testnode PathBuilder S330 Alarm Read-Write
Slot#3 DS1 IMA UNI Link Status Menu

1. Port 2
2. Port 3
3. Port 4
4. Previous Menu

Please enter a selection 1 to 4 [4]: █

```

- 4 Enter the number corresponding to the port for which you want to view IMA link status. The IMA Link Status screen for that port appears, as shown in Figure 70.

Figure 70 IMA Link Status Screen

```

Telnet - 198.93.64.100
Connect Edit Terminal Help
testnode PathBuilder S330 Alarm Read-Write
Slot#3 Link#2 DS1-CSU IMA Link Status

Group : 2                               Tx LID : 0
NE Tx State : not in group              Rx LID : 0
NE Rx State : not in group              Operation Link Delay (msec) : 0
FE Tx State : not in group              Rx Test Pattern : 255
FE Rx State : not in group              Test Procedure : disabled
NE Rx Failure : none
FE Rx Failure : none

Press any key to previous menu.

```

The IMA Link Status screen lists the following information pertaining to the IMA status of an individual link in an IMA group.

NE Tx State—The near-end transmit state in the interworking link state machine. Table 23 lists the possible link states.

NE Rx State—The near-end transmit state in the interworking link state machine. Table 23 lists the possible link states.

FE Tx State—The far-end transmit state in the interworking link state machine. Table 23 lists the possible link states.

FE Rx State—The far-end transmit state in the interworking link state machine. Table 23 lists the possible link states.

Table 23 Possible IMA Link States

State	Tx Condition	Rx Condition
not in group	This link is not part of the IMA group.	This link is not part of the IMA group.
unusable blocked	This is caused by LOS, which would result in back clock from the framer if the port is in looped timing.	This is caused by AFA, excessive delay, or mismatched protocol.
usable	This link is ready to pass data.	This link is ready to pass data.
active	This link is passing data.	This link is passing data.

NE Rx Failure—Near-end Rx failure status in the interworking link state machine. lists the possible IMA link failure status conditions. Table 24 lists the possible IMA link failure status conditions.

FE Rx Failure—Far-end Rx failure status in the interworking link state machine. Table 24 lists the possible IMA link failure status conditions.

Table 24 Possible IMA Link Failure Status Conditions

Failure	Description
link failure	This is caused by LOS, AIS, OOF, or LCD.
LIF failure	This is caused by LIF.
LODS failure	This is caused by LODS.
Misconnected	This is caused by bad IMA ID, bad link ID, or bad SCCI.
blocked	This is caused by AFA, excessive delay, or mismatched protocol.
fault	This is caused by bad M value, bad symmetry, bad offset, or duplicate link ID.
far end Tx link unusable	This is caused by the far end reporting Tx unusable in the ICP cells.
far end Rx link unusable	This is caused by the far end reporting Rx unusable in the ICP cells.
no failure	The link has no failure.

Tx LID—Transmit logical link ID: *0-31*. This number reflects the local IMA ID.

Rx LID—Receive logical link ID: *0-31*. This number reflects the remote IMA ID.

Operation Link Delay—The differential link delay referenced to the fastest link in the same group.

Rx Test Pattern—The received test pattern received: *0-254*; *255* indicates that no pattern has been received.

Test Procedure—The status of the test procedure: *disabled*, *operating*, or *link failed*.

Viewing IMA Group Status

To view IMA status for a selected group, follow these steps:

- 1 From the Configuration Management menu, select *[1] Manage Card*.
- 2 From the List Card menu, select the number corresponding to the slot in which the T1 UNI or E1 UNI card is installed to open the Group Menu.
- 3 Select *[4] IMA Group Status* to open the Group Status Selection menu, shown in Figure 71.

Figure 71 Group Status Selection Menu

```

Telnet - 198.93.64.100
Connect Edit Terminal Help
testnode PathBuilder S330 Alarm Read-Write
Slot#3 DS1 UNI Group Status Selection

1. Group 2
2. Previous Menu

Please enter a selection 1 to 2 [2]: █

```

- 4 Enter the number corresponding to the group for which you want to view IMA status. The IMA Group Status screen for that group appears, as shown in Figure 72.

Figure 72 IMA Group Status Screen

```

Telnet - 198.93.64.100
Connect Edit Terminal Help
testnode PathBuilder S330 Alarm Read-Write
Slot#3 Group#2 DS1 IMA Group Status

Operation Port(s): Rx Framers Length : 128 cells
NE State : not configured Least Delay Link : 2
FE State : not configured Oper. Link Delay (msec) : 0
Failure Status : none Tx Avabl. Cell Rate (cps) : 0
FE Tx Clocking : common Rx Avabl. Cell Rate (cps) : 0
Tx Timing Ref. Link : 2 # Tx Configured Links : 0
Rx Timing Ref. Link : 2 # Rx Configured Links : 0
Rx IMA ID : 0 # Tx Active Links : 0
NE State Last Changed : 03/15/00 # Rx Active Links : 0
06:02:31

Press any key to previous menu. █

```

The IMA Group Status screen lists the following information pertaining to the IMA status of the group as a whole.

Operation Port(s)—The port numbers of the active links in the group.

NE State—The near-end state.

FE State—The far-end state.

Failure—Failure status:

Near End Asymmetric—Near end rejected asymmetrical configuration or operation chosen by the far end.

Far End Invalid M—Far end rejected the M value chosen by the user on the near end.

Other Failures—The near end group detected multiple IMA ID, multiple M, or multiple symmetry, or the group has duplicated IMA ID, or the far end reported configuration abort without any reason.

Near End Insufficient Links—This is a normal transitional state when the near end group is coming up. If it persists, it indicates that the group indeed does not have enough links to come up and pass data.

Far End Insufficient Links—This is a normal transitional state when the far end group is coming up. If it persists, it indicates that the group indeed does not have enough links to come up and pass data.

Near End Blocked—The near end group cannot pass data due to LODS.

Far End Blocked—The far end group has enough links, but cannot pass data for some other reason.

Near End Startup—This is a normal transitional state when the near end group is coming up.

Far End Startup—This is a normal transitional state when the far end group is coming up.

No Failure—The group has no failure.

FE Tx Clocking—Far-end transmit clocking mode: *common* or *independent*.

Tx Timing Ref. Link—The near end transmitting timing reference port for cell clock recovery.

Rx Timing Ref. Link—The near end received timing reference port for cell clock recovery.

Rx IMA ID—The IMA receive group ID. This number reflects the remote IMA ID.

NE State Last Changed—The date and time at which the near-end state last changed.

Rx Framer Length—Receive M value. The frame length of the first link that can communicate with the far end is chosen as the frame length of the far end group.

Least Delay Link—The port number of the fastest link in the group.

Oper. Link Delay—Operational link delay; the actual value of the link differential delay.

Tx Available. Cell Rate (cps)—The available cell rate for active Tx links in this group: *0-28,728 cps* for T1, M=128; *0-35,920 cps* for E1, M=128. The available cell rate indicates how much bandwidth can be carried across the group. It varies, depending on how many links in the group are actually working.

Rx Available Cell Rate (cps)—The available cell rate for active Rx links in this group: *0-28,728 cps* for T1, M=128; *0-35,920 cps* for E1, M=128. The available cell rate indicates how much bandwidth can be carried across the group. It varies, depending on how many links in the group are actually working.

Tx Configured Links—The number of configured transmit links.

Rx Configured Links—The number of configured receive links.

#Tx Active links—The number of active transmit links.

#Rx Active links—The number of active receive links.

Configuring the T1/ E1 Card

The only type of configuration you can perform on the T1/E1 UNI card is to put it in service or out of service.

To put the T1/E1 UNI card in service or out of service, follow these steps:

- 1 From the Configuration Management menu, shown earlier in Figure 50, select *[1] Manage Card* to display the List Card menu, shown earlier in Figure 51.
- 2 From the List Card menu, select the number corresponding to the slot in which the T1 UNI or E1 UNI card is installed to display the T1 (DS1) UNI or E1 UNI Configuration menu, shown earlier in Figure 58.
- 3 From the T1 (DS1) UNI or E1 UNI Configuration menu, select *[5] Card Information* to display the Card Configuration menu. Figure 73 shows the T1 (DS1) UNI Card Configuration menu. The E1 UNI Card Configuration menu is the same.

Figure 73 Configuring the T1/E1 Card

```

Telnet - 198.93.64.100
Connect Edit Terminal Help
testnode PathBuilder S330 Alarm Read-Write
Slot#3 DS1 UNI Configuration

HW Rev: AA
Serial Number: BEAC002371
Admin. Status: In Service
Operation Status: In Service
Operation Group: None
Num. of IMA Group(s): 1

1. Set Admin. Status
2. Previous Menu

Please enter a selection 1 to 2 [2]: █

```

- 4 Select *[1] Set Admin Service* and enter **2** to put the card in service or **1** to take it out of service.

In addition to the current T1/E1 card configuration, the T1/E1 UNI Card Configuration menu lists the following group-related information:

Operation Group—The active IMA groups in the card.

Num. of IMA Group(s)—The number of IMA groups created (but not necessarily active) on the card.

Configuring the OC3/STM-1 Port

To configure the OC3/STM-1 port, follow these steps:



The PathBuilder S310 does not support OC3/STM-1; the OC3/STM-1 port is disabled on that device.

- 1 From the Configuration Management menu, shown in Figure 50, select [1] *Manage Card* to display the List Card menu, shown in Figure 51.
- 2 From the List Card menu, select [4] *OC3 UNI* to open the SONET UNI Configuration menu, shown in Figure 74. This menu displays the current configuration for the OC3/STM-1 port and provides options that allow you to change certain settings.

Figure 74 Configuring the OC3/STM-1 Port

```

Telnet - 198.93.64.100
Connect Edit Terminal Help
testnode PathBuilder S330 Alarm Read-Write
Slot#4 SONET UNI Configuration

Fiber type: Multi-Mode
HW Rev: AA
Serial Number: BEAC002371
Admin. Status: Out of Service
Operation Status: Out of Service
Sonet Interface Mode: oc-3
ATM Payload Scramble: Yes
Timing Source: System

1. Set Admin. Status
2. Set Sonet Interface Mode
3. Set ATM Payload Scramble
4. Set Timing Source
5. Previous Menu

Please enter a selection 1 to 5 [5]: █

```

- 3 Set the following parameters as desired:

Admin. Status—Administrative status: *Out of Service* or *In Service*.

Sonet Interface Mode—The SONET interface supports two modes: *OC3* and *STM-1*. Choose the mode used at your location. *OC3* is used most often in the United States, while *STM-1* is common in other countries.

ATM Payload Scramble—Enables (*yes*) or disables (*no*) payload scrambling for the OC3/STM-1 port. The default is disabled (*no*). Payload scrambling is a technique used to avoid certain transmission equipment behaviors (for example, erroneous alarm conditions) that are caused by sensitivity to certain bit patterns in the ATM payload. When you set payload scrambling to *yes*, the ATM Payload Scramble scrambles the 48 byte payload in outgoing cells in a defined manner and unscrambles the payload in incoming cells. The payload scramble settings must match at the two ends of the OC3/SDH trunk.

Timing Source—The timing source for the OC3/STM-1 transmit clock.

Loop—Configures the OC3/STM-1 port interface to use the input port Rx clock as the timing source; timing is received from the service “loop.” Select *Loop* if the OC3/STM-1 port is used for the network/carrier service termination, in which case the carrier (the service “loop”) typically provides the timing source.

System—Configures the OC3/STM-1 port interface to use the internal system clock as the timing source.

Configuring the DS3/E3 UNI Module

To configure the DS3 UNI or E3 UNI module, follow these steps:

- 1 From the List Card menu, select [9] *DS3 UNI* to open the DS3 UNI Configuration menu. Figure 75 shows the DS3 UNI Configuration menu. The E3 UNI Configuration menu is similar.

Figure 75 DS3 UNI Configuration Menu

```

Telnet - 209.31.3.23
Connect Edit Terminal Help
testnode PathBuilder S330 Alarm Read-Write
Slot#9 DS3 UNI Configuration

HW Rev:
Serial Number:
Admin. Status: In Service
Operation Status: No Response

LBO Length: "<255"
DS3 Framing Mode: CBIT
ATM Cell Mapping: PLCP
ATM Payload Scramble: Yes

FEAC Loopback: Disable
DS3 Timing Source: System
PLCP Timing Source: DS3 Timing
CTX Timing Source: DS3 Rx Clock

1. Set Admin. Status
2. Set LBO Length
3. Set DS3 Framing Mode
4. Set ATM Cell Mapping
5. Set ATM Payload Scramble
6. Set FEAC Loopback
7. Set DS3 Timing Source
8. Set PLCP Timing Source
9. Set CTX Timing Source
10. Previous Menu

Please enter a selection 1 to 10 [10]: █

```

- 2 Set the following parameters as desired:

Admin Status—Administrative Status: *In Service* or *Out of Service*.

LBO Length (DS3 only)—Line Build Out length. The signal generation/regeneration of the distance between the PathBuilder S600 and the next crossconnect or FOTs (Fiber Optic Terminal system), in feet: 0-225 or 225-450.

DS3 Framing Mode (DS3 only)—The type of frame organization configured for the specified port interface: *Cbit* or *M23*. Set this parameter to match the framing type offered by your service provider. *Cbit* is the most common setting, as its use of overhead bits for administration and maintenance allows the service provider more visibility in isolating any issues with the physical line connections through the WAN. You must match this setting at the two ends of the DS3 trunk.

ATM Cell Mapping—How the carrier will provision the DS3 UNI service from the carrier ATM switch: *Clear* (HEC) or *PLCP* (Physical Layer Convergence Protocol). *Clear* is the option preferred by both domestic and international service providers and within private ATM networks, as it gives more payload bandwidth than *PLCP*. You must match this setting at the two ends of the DS3 trunk.

ATM Payload Scramble—Enables (*yes*) or disables (*No*) payload scrambling for the DS3 port. Payload scrambling scrambles the 48-byte payload in outgoing cells in a defined manner and unscrambles the payload in incoming cells. It is a technique used to avoid certain transmission equipment behaviors (for example, erroneous alarm conditions) that are caused by sensitivity to certain bit patterns in the ATM payload. You must match this setting at the two ends of the DS3 trunk.

FEAC Loopback (DS3 only)—Enables or disables the system from responding to FEAC (Far-End Alarm Condition) loopback commands (loopback activate and deactivate FEAC codes) from the central office. FEAC is a DS3 overhead function that the service provider may use for establishing loopback for problem resolution of the network. The service provider uses FEAC codes to obtain downstream or upstream conditions of a DS3 network. When the FEAC Loopback option is enabled, the system responds to a loopback activate command by enabling the DS3 line loopback. The system removes the loopback automatically after 15 minutes or when it receives the deactivate command.

DS3 Timing Source (DS3 only)—The timing source for the DS3 transmit clock: *system* or *loop*. If you set the *DS3 Timing Source* to *system* at one end of the DS3 trunk, you must set it to *loop* at the other end.

System—Configures the port interface to use the system reference clock within the shelf as a reference for transmitting.

Loop—Configures the port interface to use the input port Rx clock as the timing source; timing is received from the service “loop.” Select this option if the DS3 UNI module is used for the network/carrier service termination, in which case the carrier (the service “loop”) typically provides the timing source.

E3 Timing Source (E3 only)—The timing source for the E3 transmit clock: *system* or *loop*. If you set the *E3 Timing Source* to *system* at one end of the E3 trunk, you must set it to *loop* at the other end.

System—Configures the port interface to use the system reference clock within the shelf as a reference for transmitting.

Loop—Configures the port interface to use the input port Rx clock as the timing source; timing is received from the service “loop.” Select this option if the E3 UNI module is used for the network/carrier service termination, in which case the carrier (the service “loop”) typically provides the timing source.

PLCP Timing Source (DS3 only)—The PLCP timing source for the DS3 port:

System Clock—PLCP is timed from the internal 8kHz backplane clock.

DS3 Timing—PLCP is timed from the 8kHz reference clock derived from the received PLCP.

CTX Timing Source—The CTX timing source for the DS3/E3 port.

DS3/E3 Rx Clock—Selects the DS3 or E3 Rx clock as the CTX timing source.

Configuring the Serial Interface

Configuring the serial interface involves the following tasks:

- Configuring the serial port
- Configuring the serial card

Configuring the Serial Port

To configure the serial port, follow these steps:

- 1 From the Configuration Management menu, select *[1] Manage Card* to display the List Card menu, shown earlier in Figure 51.
- 2 From the List Card menu, select *[5] SIM* to display the SIM Configuration Port/Card Selection menu, shown in Figure 76.

Figure 76 SIM Configuration Port/Card Selection Menu

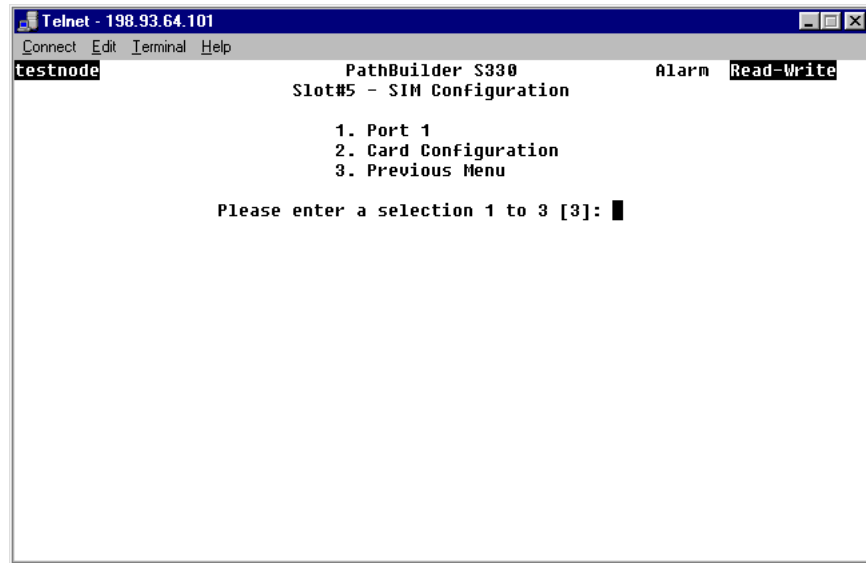

- 3 Select *[1] Port 1* to display the SIM Port Configuration Port/LMI selection menu, shown in Figure 77.

Figure 77 SIM Port Configuration Port/LMI Selection Menu

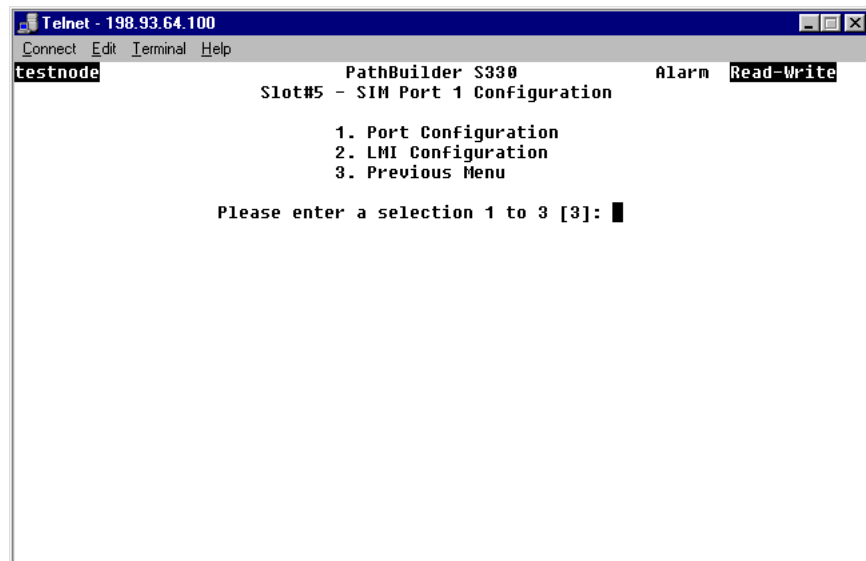

- 4 Select *[1] Port Configuration* to display the SIM Port Configuration menu, shown in Figure 78. This menu displays the current serial port configuration and provides options that allow you to change certain parameters.

Figure 78 Configuring the Serial Port

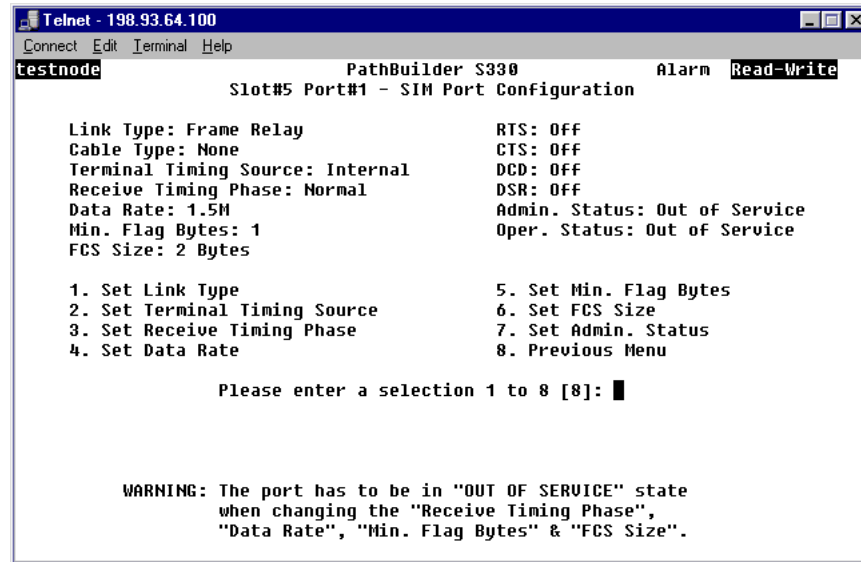

- 5 Change the following parameters, as desired:

Link Type—The input/output protocol for encapsulation and SAR to AAL5 conversion.

DXI —ATM Forum Mode 1A

SDLC—ITU standard HDLC/SDLC frame

Frame Relay—Frame Relay Forum Specification 5 and 8; modes 1 and 2

Terminal Timing Source—This parameter applies only when the attached cable is DCE type cable. The setting for the Terminal Timing depends on the nature and speed of the device application, but the typical configuration is *Internal*—the PathBuilder S330/S310 provides the clock for the device application. In any case, the Terminal Timing Source setting for the PathBuilder S330/S310 serial port must be the opposite of that for the device. For example, if the Terminal Timing Source for the router is set to Internal, then you must set the Terminal Timing Source for the serial port to External.

Internal—Configures the port to use the internal clock as the terminal timing source. The PathBuilder S330/S310 provides the clock to clock in the data traffic from a router or other data device.

External—Configures the port to use an external device as the terminal timing source. The PathBuilder S330/S310 accepts the clock for data from the router or other data device.

Receive Timing Phase—Receive timing phase control. This parameter applies only when the attached cable is DCE type cable. Depending on the speed of the device application and the clock phases, particularly those of the return clock, you may have to set *Receive Timing Phase* to *Inverted* (invert the clock) to ensure correct clock and data phase. This option is used most often to correct for cable length delays when *Terminal Timing* is set to *Internal*.

Normal—The receive timing from the remote endpoint (node) is normal clocking.

Inverted—The receive timing from the remote endpoint (node) is inverted clocking.

Data Rate—The data rate supported by the port: 48K, 97K, 195K, 390K, 781K, 1.5M, 3.1M, or 6.2M. This parameter applies only when the attached cable is DCE type cable. It is a very important parameter, as it allows you to direct the SIM to shape particular data applications so as not to exceed the guaranteed bandwidth established by your service provider in your service contract. The *Data Rate* setting also allows you to optimize the entire WAN ATM application by traffic engineering your ATM access applications so as to maintain traffic flow across the network.

Min. Flag Bytes—The minimum number of flag bytes required to distinguish a frame: 1, 2, 4, 6, 8, 10, 12, or 14.

FCS Size—The number of bytes to use for FCS (Frame Check Sequence) calculation for each frame. FCS is the CRC remainder sent at the end of a frame. This parameter is valid only for HDLC/SDLC data.

Admin. Status—Administrative status: Out of Service or In Service.

- 6 Select [8] *Previous Menu* to return to the SIM Port Configuration Port/LMI Selection menu, shown earlier in Figure 77.
- 7 If desired, selected [2] *LMI Configuration* to display the SIM LMI Configuration menu, shown in Figure 79. This menu allows you to set the protocol for the local management interface.



You can set the LMI protocol only if the Link Type is set to Frame Relay on the SIM Port Configuration menu. If the Link Type is set to DXI or SDLC, the LMI Configuration option does not appear on the SIM Port Configuration Port/LMI selection menu, shown earlier in Figure 76.

Figure 79 SIM LMI Configuration Menu

```

Telnet - 198.93.64.100
Connect Edit Terminal Help
testnode PathBuilder S330 Alarm Read-Write
Slot#5 Port#1 - SIM LMI Configuration

Protocol: none

1. Set Protocol
2. Previous Menu

Please enter a selection 1 to 2 [2]:

```

- 8 Select [1] *Set Protocol*. The following prompt appears at the bottom of the screen:
(1 = none, 2 = q.933a, 3 = t1.617d)
- 9 Enter the number corresponding to the desired protocol or **1** for no LMI.

Configuring the Serial Card

The only type of configuration you can perform on the serial card is to put it in service or out of service. To set the administrative status of the serial card, follow these steps:

- 1 From the Configuration Management menu, shown earlier in Figure 50, select [1] *Manage Card* to display the List Card menu, shown in Figure 51.
- 2 From the List Card menu, select [5] *SIM* to display the SIM Configuration Port/Card Selection menu, shown in Figure 76.
- 3 Select [2] *Card Configuration* to display the SIM Card Configuration menu, shown in Figure 80.

Figure 80 Configuring the Serial Card

```

Telnet - 198.93.64.100
Connect Edit Terminal Help
testnode PathBuilder S330 Alarm Read-Write
          Slot#5 - SIM Card Configuration

          HW Rev: AA
          Serial Number: BEAC002371
          Admin. Status: In Service
          Oper. Status: In Service
          Max. Frame Size: 8 KB

          1. Set Admin. Status
          2. Previous Menu

          Please enter a selection 1 to 3 [3]: █
  
```

- 4 Select [1] *Set Admin. Status* to put the Ethernet card in service or out of service.



The maximum frame size is fixed at 8KB.

Configuring the Ethernet Interface

Configuring the Ethernet interface involves the following tasks:

- Configuring the Ethernet port
- Configuring the Ethernet card
- Configuring the bridge

Configuring the Ethernet Port

The only type of configuration you can perform on the Ethernet port is to put it in service or out of service. To set the administrative status of the Ethernet port, follow these steps:

- 1 From the Configuration Management menu, select [1] *Manage Card* to display the List Card menu, shown earlier in Figure 51.
- 2 From the List Card menu, select [6] *ETHERNET* to display the Ethernet Configuration Port/Card Selection menu, shown in Figure 81.

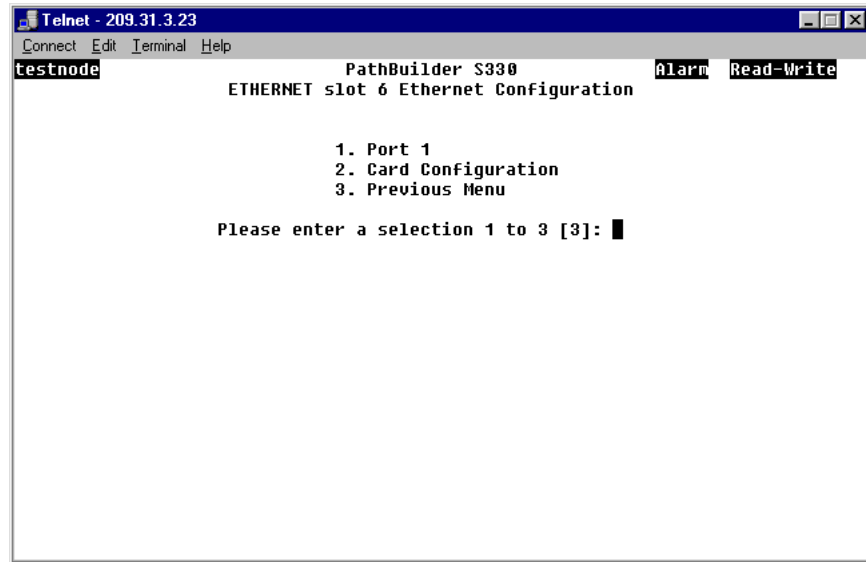
Figure 81 Ethernet Configuration Port/Card Selection Menu

```
Telnet - 209.31.3.23
Connect Edit Terminal Help
testnode PathBuilder S330 Alarm Read-Write
ETHERNET slot 6 Ethernet Configuration

1. Port 1
2. Card Configuration
3. Previous Menu

Please enter a selection 1 to 3 [3]: █
```

- 3 Select *[1] Port 1* to display the Ethernet Port Configuration menu, shown in Figure 82. This menu displays the current Ethernet port configuration and provides an option that allows you to set the administrative status for the Ethernet port.

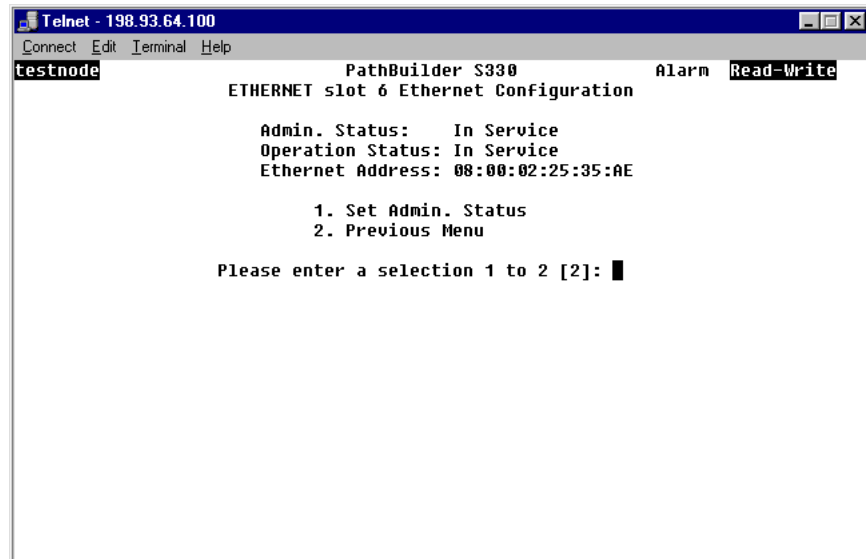
Figure 82 Configuring the Ethernet Port

```
Telnet - 198.93.64.100
Connect Edit Terminal Help
testnode PathBuilder S330 Alarm Read-Write
ETHERNET slot 6 Ethernet Configuration

Admin. Status: In Service
Operation Status: In Service
Ethernet Address: 08:00:02:25:35:AE

1. Set Admin. Status
2. Previous Menu

Please enter a selection 1 to 2 [2]: █
```

- 4 Select *[1] Set Admin. Status* to put the Ethernet port in service or out of service.

Configuring the Ethernet Card

The only type of configuration you can perform on the Ethernet card is to put it in service or out of service. To set the administrative status of the Ethernet card, follow these steps:

- 1 From the Configuration Management menu, select *[1] Manage Card* to display the List Card menu, shown earlier in Figure 51.
- 2 From the List Card menu, select *[6] ETHERNET* to display the Ethernet Configuration Port/Card Selection menu, shown earlier in Figure 81.

- 3 Select *[2] Card Information* to display the Ethernet Card Configuration menu, shown in Figure 83. This menu displays the current Ethernet card configuration and provides an option that allows you to set the administrative status for the Ethernet card.

Figure 83 Configuring the Ethernet Card

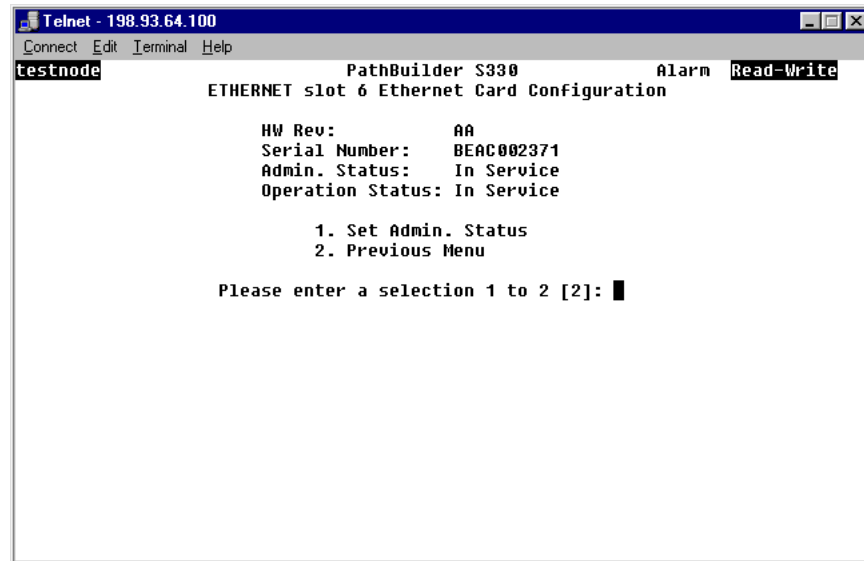

- 4 Select *[1] Set Admin. Status* to put the Ethernet card in service or out of service.

Configuring the Bridge

All of the virtual channels assigned to a particular slot and port form a network bridge. In order to enable the Ethernet port to operate, you must configure the bridge with the required user-filtering options and an aging timer value.

The aging timer value you specify will be listed in the Age column on the List Forwarding Table. The system deletes station address entries when they have had no traffic for the specified period of time. To keep addresses in the List Forwarding table permanently, set the Aging Timer to Permanent. For further details about the List Forwarding Table, see "Viewing the List Forwarding Table" later in this chapter.

To configure the bridge, follow these steps:

- 1 From the Configuration Management menu, select *[3] Manage Bridge* to display the Manage Bridge menu, shown in Figure 84.

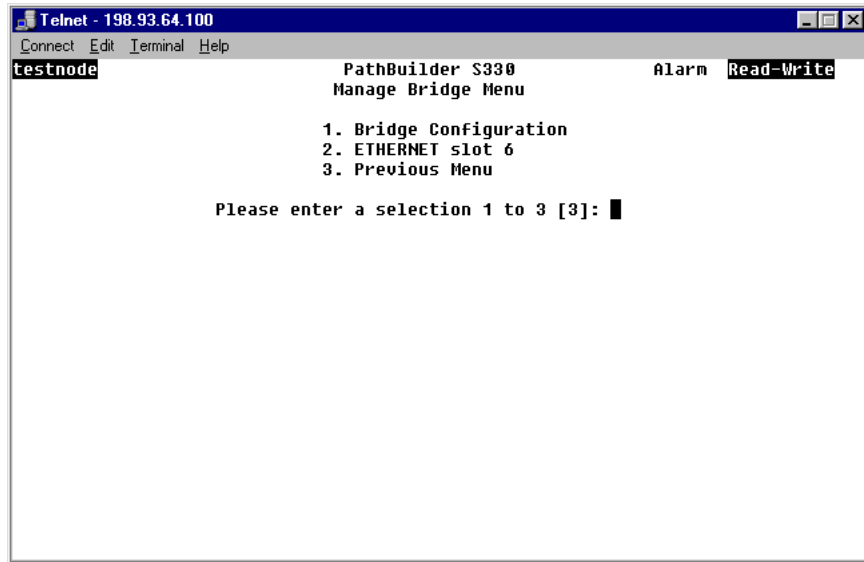
Figure 84 Manage Bridge Menu

- From the Manage Bridge menu, select [1] *Bridge Configuration* to display the Bridge Configuration menu, shown in Figure 85. The current aging timer setting is displayed below the menu title (3 minutes in the sample menu shown in the figure).

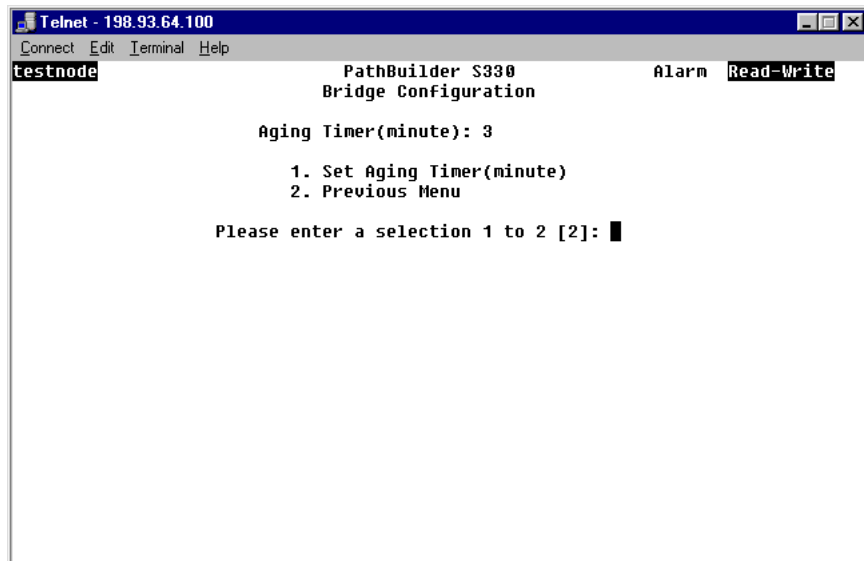
Figure 85 Bridge Configuration Menu

- Select [1] *Set Aging Timer*. The following prompt appears at the bottom of the screen:
Enter Aging Timer (minute):
- Enter the desired timer interval, in minutes.
- Select [2] *Previous Menu* to return to the Manage Bridge menu.
- From the Manage Bridge menu, select [2] *Ethernet Slot #6 Port 1* to display the Bridge Menu for the Ethernet port, as shown in Figure 86.

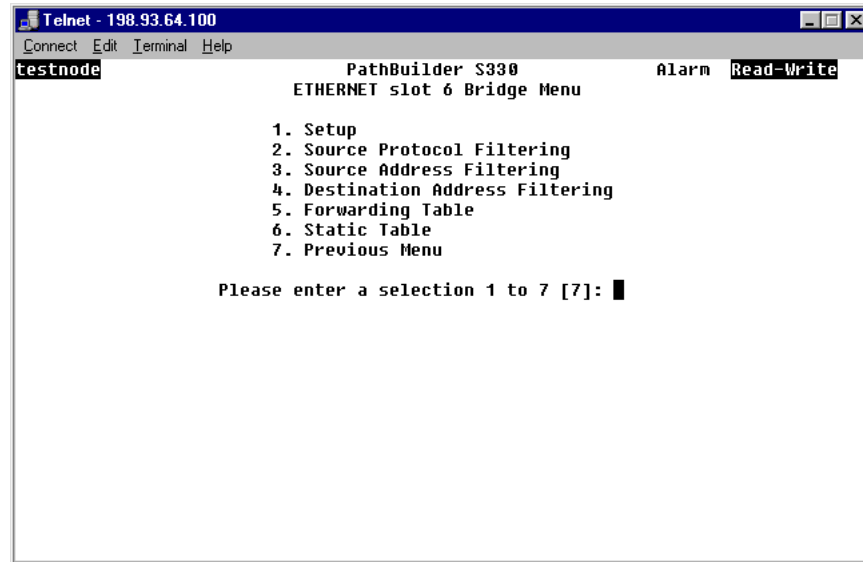
Figure 86 Bridge Menu

From the Bridge menu, you can:

- Configure source protocol filtering, source address filtering, and destination address filtering.
- Display the forwarding table for the bridge.
- Construct a static table (a table of source/destination pairs which you do not want to be aged out of the forwarding table) for the bridge.

The following subsections tell you how to perform these operations.

Configuring Source Protocol Filtering

Source protocol filtering allows the bridge to filter out packets with certain protocols. You can use this type of filtering to prevent certain type of protocol traffic from being bridged across the ATM network. Protocols such as IPX and Appletalk, for example, can be filtered on the sending end. This is useful in restricting your local Novell network or Appletalk data traffic from being transmitted on long distance ATM links, thereby saving bandwidth and providing security.

To configure source protocol filtering, follow these steps:

- 1 From the Bridge Configuration menu, select [2] *Source Protocol Filtering* to display the Source Protocol Filter menu, shown in Figure 87.

Figure 87 Source Protocol Filter Menu

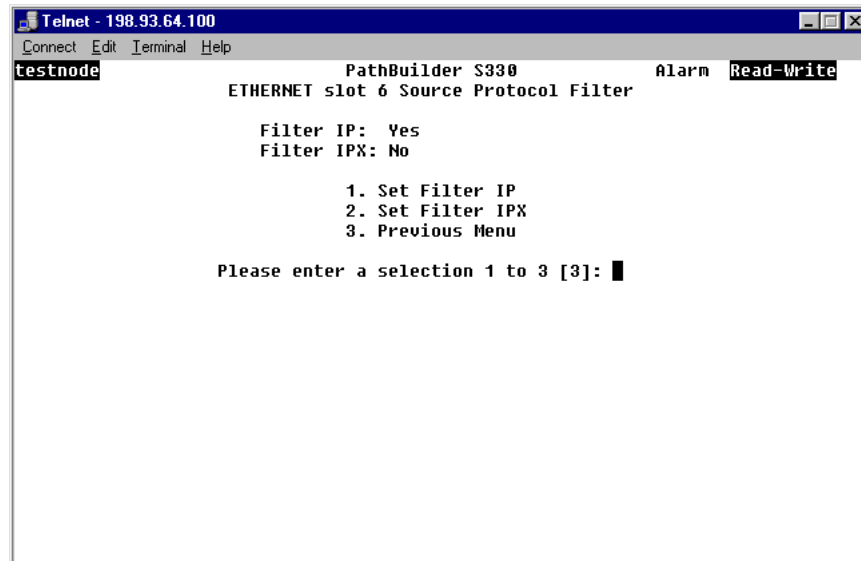

The current statuses of the source protocol filters are listed at the top of the menu. Yes indicates that packets with that protocol will be rejected. No indicates that packets with that protocol will be transmitted across the bridge.

- 2 Change the filter settings as desired by entering the number corresponding to the filter you want to set and responding to the prompt that appears at the bottom of the screen. The list at the top of the menu is updated to reflect your change.

For example, if you want to configure an IP filter, select [1] *Set Filter IP*. The following prompt appears at the bottom of the screen:

```
Enter Filter IP (1=No, 2=Yes):
```

Enter **2** to configure an IP filter; the bridge will reject packets with IP (Internet Protocol).

- 3 Select [3] *Previous Menu* to return to the Bridge menu.
- 4 Select [1] *Setup* to display the Bridge Setup menu, shown in Figure 88. This menu allows you to enable or disable the filters you have configured.

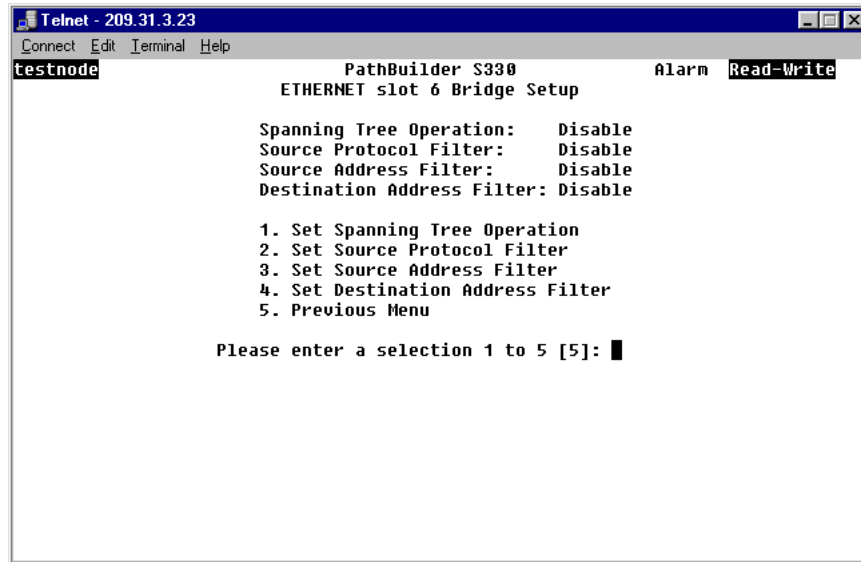
Figure 88 Bridge Setup Menu

- 5 Select [1] *Set Source Protocol Filter*. The following prompt appears at the bottom of the screen:

Enter Source Protocol Filter (1=Disable, 2=Enable)

- 6 Enter **2** to enable the source protocol filter.

Configuring Source Address Filtering

Source address filtering allows the bridge to prevent packets containing a specific source address from traversing the bridge. You can use source address filtering to prevent some stations from transmitting on the ATM WAN link. This type of filtering is useful for preventing specific stations in a common protocol group on the Ethernet LAN from transmitting bursty and useless network data across the bridge and onto the WAN.

To configure source address filtering, follow these steps:

- 1 From the Bridge menu, select *[3] Source Address Filtering* to display the Source Address Filter menu, shown in Figure 89.

Figure 89 Source Address Filter Menu

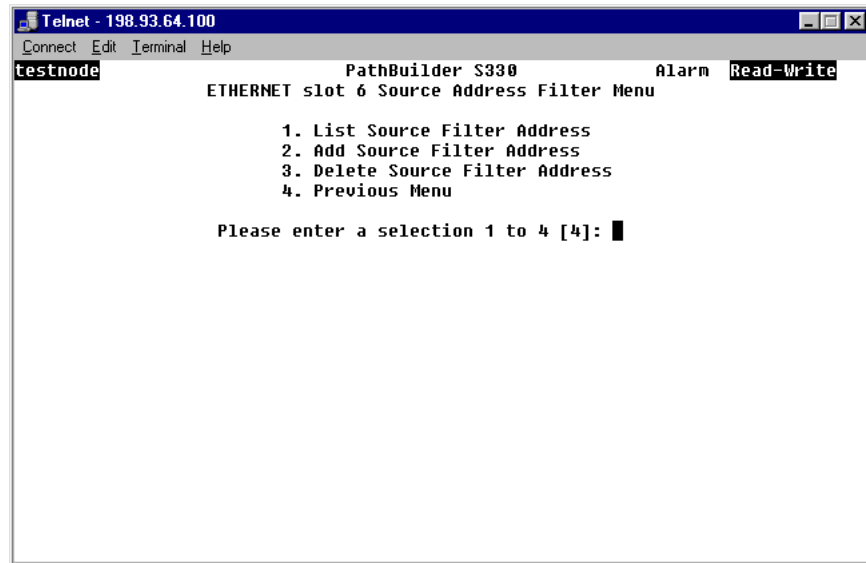

- 2 Select *[2] Add Source Filter Address*. The Add Source Address Filter screen appears. This screen displays the following prompt:

Enter MAC Address (XX:XX:XX:XX:XX:XX or <CR>):

- 3 Enter the MAC address of the station from which you do not want packets to traverse the bridge. After you make your entry, you are returned to the Source Address Filter menu.
- 4 Repeat steps 2 and 3, as desired, to add more addresses to the source filter list.
 - To view the current list, select *[1] List Source Filter Address* from the Source Filter Address menu.
 - To change an address in the list, delete the incorrect address and add the correct address.
 - To delete an address from the list, select *[3] Delete Source Filter Address* from the Source Filter Address menu and enter the number corresponding to the address you want to delete. Then enter **y** at the confirmation prompt to delete the selected address.
- 5 Select *[4] Previous Menu* to return to the Bridge menu
- 6 Select *[1] Setup* to display the Bridge Setup menu, shown earlier in Figure 88. This menu allows you to enable or disable the filters you have configured.
- 7 Select *[2] Set Source Address Filtering*. The following prompt appears at the bottom of the screen:

Enter Source Address Filter (1=Disable, 2=Enable)

- 8 Enter **2** to enable the source address filter.

Configuring Destination Address Filtering

Destination address filtering prevents LAN packets with destination addresses specified in the filter from being sent to the WAN. You can use destination address filtering to prevent some stations from receiving data from the ATM WAN link. For example, you can save network-traffic-sensitive stations (such as local file servers and CAD servers) from unnecessary data coming from the WAN.

To configure destination address filtering, follow these steps:

- 1 From the Bridge menu, select *[4] Destination Address Filtering* to display the Destination Address Filter menu, shown in Figure 90.

Figure 90 Destination Address Filter Menu

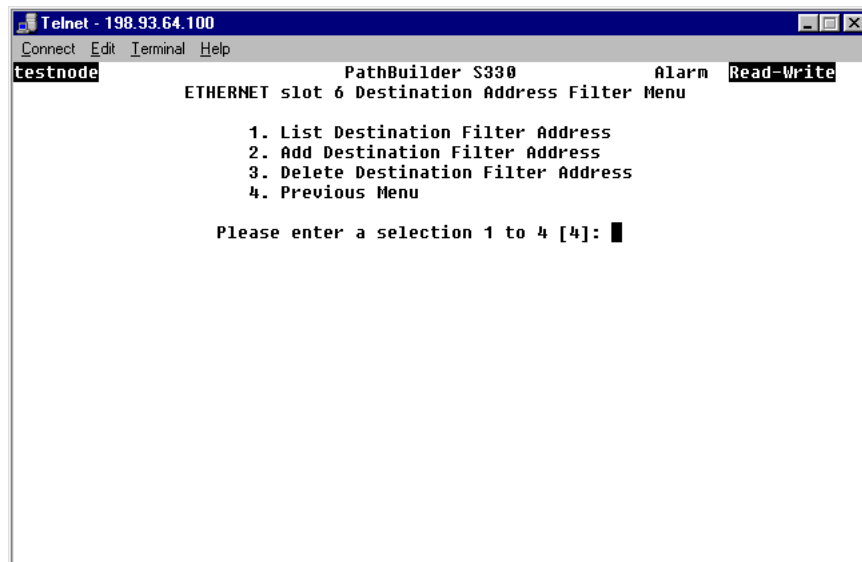

- 2 Select *[2] Add Destination Filter Address*. The Add Destination Address Filter screen appears. This screen displays the following prompt:
Enter MAC Address (XX:XX:XX:XX:XX:XX or <CR>):
- 3 Enter the MAC address of the destination to which you do not want packets to be sent across the bridge. After you make your entry, you are returned to the Source Address Filter menu.
- 4 Repeat steps 2 and 3, as desired, to add more addresses to the destination filter list.
 - To view the current list, select *[1] List Destination Filter Address* from the Destination Filter Address menu.
 - To change an address in the list, delete the incorrect address and add the correct address.
 - To delete an address from the list, select *[3] Delete Destination Filter Address* from the Destination Filter Address menu and enter the number corresponding to the address you want to delete. Then enter **2** at the confirmation prompt to delete the selected address.
- 5 Select *[4] Previous Menu* to return to the Bridge menu.
- 6 Select *[1] Setup* to display the Bridge Setup menu, shown earlier in Figure 88. This menu allows you to enable or disable the filters you have configured.

- 7 Select *[3] Set Destination Address Filter*. The following prompt appears at the bottom of the screen:

```
Enter Destination Address Filter (1=Disable, 2=Enable)
```

- 8 Enter **2** to enable the destination address filter.

Viewing the List Forwarding Table

The List Forwarding Table is a current forwarding table for the bridge. To display this table, select *[5] Forwarding Table* from the Bridge menu. Figure 91 shows a representative List Forwarding Table.

Figure 91 List Forwarding Table

```

Telnet - 198.93.64.100
Connect Edit Terminal Help
testnode PathBuilder S330 Alarm Read-Write
ETHERNET slot 6 List Forwarding Table

MAC Address      Disp.      Location      Age
1. 00:00:0C:3E:A8:39 Bridge    ENET 6        0 secs
2. 00:80:3F:20:03:91 Bridge    ENET 6       150 secs
3. 08:00:02:25:35:AE Local      ENET 6      Permanent

Press ESC to go to previous menu.

```

The List Forwarding Table identifies the port on which a certain MAC address is located. This can be an Ethernet port or an ATM VC. Using the information in the List Forwarding table, the bridge knows where to send a MAC address when it receives one. If the Ethernet port receives a packet, and the destination MAC address is not in the List Forwarding table, the port broadcasts the packet—sends it to all Vxs associated with that port.

The List Forwarding Table includes the following columns of information:

MAC Address—The destination MAC address.

Disp.—Disposition:

Bridge—The default disposition.

Flood—Flood the frame on all available VCs.

Filter—Drop this frame.

L_Static—Destination MAC address is in Bridge Static Table.

SRC_Address_Filtering—User-configured source address filter.

DEST_Address_Filtering—User-configured destination address filter.

Location— The port (slot and port number) on which the destination MAC address is located.

Age—The age of the station address entry in the List Forwarding Table: *Permanent* (indicating that the entry is on the Bridge Static Table) or a specified number of seconds. To specify the age, change the Aging Timer setting on the Bridge Configuration menu. See “Configuring the Bridge” earlier in this chapter, for details. The system uses the Age parameter to delete station address entries when they have had no traffic for the specified period of time.

Constructing the Bridge Static Table

The Bridge Static Table is a list of destination MAC addresses that you want to maintain in the List Forwarding Table and do not want to be purged by the aging timer. The *Disp.* column for these addresses in the Forwarding Table reads *L-Static* to indicate that they will remain in the Forwarding Table until they are manually deleted from the Static Table.

To construct the Bridge Static Table, follow these steps:

- 1 From the Bridge menu, select [6] *Static Table* to display the Bridge Static Table menu, shown in Figure 92. From this menu, you can view the Static table and add and delete entries from it.

Figure 92 Bridge Static Table Menu

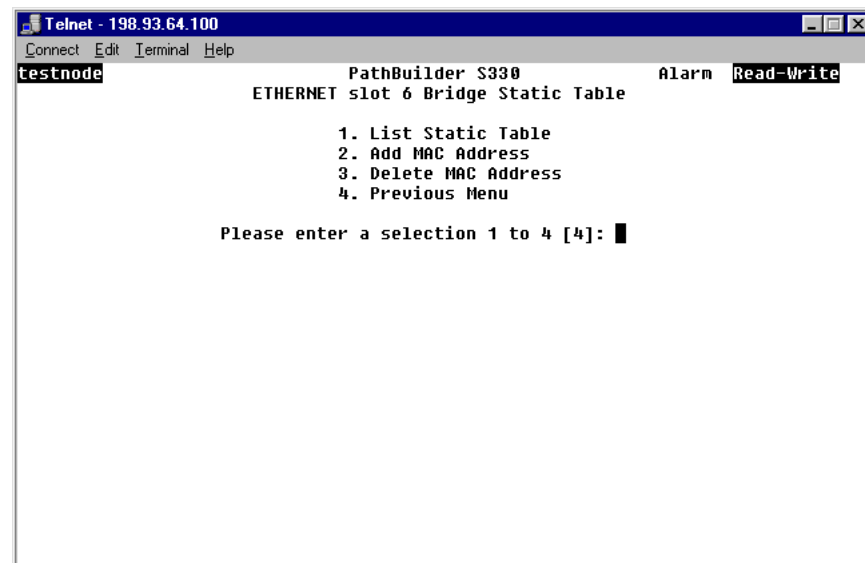

- 2 Select [2] *Add MAC Address*. The Add MAC address screen appears. This screen displays the following prompt:

```
Enter MAC Address (XX:XX:XX:XX:XX:XX or <CR>):
```
- 3 Enter the destination MAC address that you want to add to the Bridge Static Table. This address will not be purged when the List Forwarding Table is aged, and the Age column on the List Forwarding Table will display *Permanent* for this entry.
- 4 Repeat steps 2 and 3, as desired, to add more addresses to the Bridge Static Table.
 - To view the current Bridge Static Table, select [1] *List Static Table* from the Bridge Static Table menu.
 - To delete an address from the table, select [3] *Delete MAC Address* from Bridge Static Table menu and enter the number corresponding to the address you want to delete. Then enter **y** at the confirmation prompt to delete the selected address from the Bridge Static Table.

Enabling and Disabling the Spanning Tree

Spanning Tree (IEEE 802.1d) is a technique that detects loops in a network and logically blocks the redundant paths, ensuring that only one route exists between any two LANs. It eliminates the duplication of packets and provides fault tolerance for resilient networks.

To enable or disable the Spanning Tree, follow these steps:

- 1 From the Configuration Management menu, select *[3] Manage Bridge* to display the Manage Bridge menu, shown earlier in Figure 84.
- 2 From the Manage Bridge menu, select the number corresponding to the slot and port combination for which you want to enable or disable the Spanning Tree. The Bridge Menu for the selected slot/port combination appears, as shown earlier in Figure 86.
- 3 Select *[1] Setup* to display the Bridge Setup menu, shown earlier in Figure 88.
- 4 Select *[1] Set Spanning Tree Operation*. The following prompt appears:
Enter Spanning Tree Operation (1=Disable, 2=Enable):
- 5 Enter **1** or **2** to disable or enable the Spanning Tree.



For further information on Spanning Tree and how it operates, see "Typical Ethernet and Voice Application Configurations" in Appendix B.

Configuring the CBR Module

The optional CBR module features three T1/E1 CBR ports and one serial port (PathBuilder S330) or one T1/E1 CBR port and one serial port (PathBuilder S310).

Configuring the CBR module involves the following tasks:

- Configuring the CBR T1/E1 port(s)
- Configuring the CBR serial port
- Configuring the CBR card

Configuring the CBR T1-DSX/E1 Port(s)

To configure the CBR T1-DSX/E1 port(s), follow these steps:

- 1 From the Configuration Management menu, select *[1] Manage Card*.
- 2 From the List Card menu, shown earlier in Figure 51, select *[7] CBR* to open the CBR Configuration Selection menu. Figure 93 shows the CBR E1 Configuration Selection menu. The CBR T1-DSX Configuration Selection menu is the same.

Figure 93 CBR E1 Configuration Menu

```

Telnet - 198.93.64.100
Connect Edit Terminal Help
testnode PathBuilder S330 Alarm Read-Write
Slot#7 CBR E1 and U35 Configuration

1. Port 1
2. Port 2
3. Port 3
4. Port 4 (U.35)
5. Card Configuration
6. Previous Menu

Please enter a selection 1 to 6 [6]: █

```

- 3** Select the option corresponding to the port you want to configure ([1] Port 1, [2] Port 2, or [3] Port 3). The CBR T1-DSX/E1Port Configuration menu for the selected port appears. Figure 94 shows a CBR Port Configuration menu for an CBR E1 card.



For the PathBuilder S310, you can configure only one T1-DSX/E1 port on the CBR module.

Figure 94 CBR E1 Port Configuration Menu (Unstructured Mode)

```

Telnet - 209.31.3.23
Connect Edit Terminal Help
testnode PathBuilder S330 Alarm Read-Write
Slot#7 Port#1 - CBR E1 Configuration

Line Code: HDB3           Signaling: No Signaling
Port Mode: Unstructured   CRC-4: Disabled
Framing: No Framing      Admin. Status: Out of Service
Timing: Loop             Operation Status: Out of Service
Idle Timer: 5 seconds    Sel DS0 Chan's: None

1. Set Port Mode          5. Set CRC-4
2. Set Framing            6. Set Admin. Status
3. Set Timing             7. Previous Menu
4. Set Idle Timer

Please enter a selection 1 to 7 [7]: █

```

As shown in Figure 95, if you set the Port Mode to Structured Voice, you can set additional trunk conditioning (TC) parameters on the CBR Port Configuration menu.

Figure 95 CBR E1 Port Configuration Menu (Structured Voice Mode)

```

Telnet - 209.31.3.23
Connect Edit Terminal Help
testnode PathBuilder S330 Alarm Read-Write
Slot#7 Port#1 - CBR E1 Configuration

Line Code: HDB3 Idle Timer: 5 seconds
Port Mode: Struct Voice Signaling: CAS
Framing: multi-frame CRC-4: Enabled
TC Signaling Type: R2(E1) Admin. Status: Out of Service
TC1 Signaling Bits: on-hook Operation Status: Out of Service
TC2 Signaling Bits: off-hook Sel DS0 Chan's: None
Timing: Loop

1. Set Port Mode 6. Set Timing
2. Set Framing 7. Set Idle Timer
3. Set TC Signaling Type 8. Set CRC-4
4. Set TC1 Signaling Bits 9. Set Admin. Status
5. Set TC2 Signaling Bits 10. Previous Menu

Please enter a selection 1 to 10 [10]: █

```

4 Set the following port configuration parameters.

LBO (T1-DSX only)—Line Build Out. LBO refers to the signal generation/regeneration of the distance between the PathBuilder S330/S310 and the next crossconnect of FOTs (Fiber Optic Terminal system), in feet: 1-100, 100-200, 200-300, 300-400, 400-500 or 500-600.

Line Code (T1-DSX only)—The zero code suppression technique configured to the CBR T1-DSX port. Set this parameter to match the service provider or device connection line coding. The default is *B8ZS*. The *Line Code* must match at local and remote ports.

AMI—Alternate mark inversion; a T1 (1.544 Mbps) carrier line coding format whereby successive ones (marks) are alternately inverted.

B8ZS—Binary 8 Zero Substitution; a T1 (1.544Mbps) carrier line coding format used to accommodate “ones density” for clear channel transmission.



The Line Code for CBR E1 ports is a read-only parameter and is always set to HDB3.

Port Mode—The type of service configured to the specified port:



Both Structured Data and Structured Voice modes allow end to end DS0 connectivity.



For PRI (Primary Rate Interface) signaling, you must set the Port Mode to Structured Voice.

Structured Data — Structured service provides N x 64 kbit/second capability, where N ranges between 1 and the maximum number of available DS0 channels. Structured data service passes traffic with signaling information disabled—it provides for DS0 midspan carrier access without A & B signaling bits terminating DS1 or E1 framing at the CBR T1-DSX or CBR E1 interface.

Structured Voice — Structured service provides N x 64 kbit/second capability, where N ranges between 1 and the maximum number of available DS0 channels. Structured voice service passes traffic with signaling information enabled—it provides for DS0 midspan carrier access with A & B signaling bits terminating DS1 or E1 framing at the CBR T1-DSX or CBR E1 interface.

In structured voice mode, you can build either structured voice or structured data virtual circuits.

Unstructured — Unstructured service provides T1-DSX or E1 frame tunneling; it allows the application to utilize the entire available bandwidth at a bit rate of 1.544 (T1) or 2 (E1) Mbps. T1-DSX framing is optional in this service mode.

Framing—The type of frame organization configured for the T1-DSX or E1 port interface: *D4* or *ESF* for the CBR T1-DSX module; *G.704* for the CBR E1 module. Set this parameter to match the service provider or device connection framing. The *Framing* must match at local and remote ports.



CAUTION: *A framing mismatch can cause LOF, OOF alarm conditions and result in traffic loss.*

TC Signaling Type (Structured Voice mode only)—The trunk condition signaling type: *PLAR*, *E&M/PLAR*, *FXS*, *FXO*, *FXS-GroundStart*, or *FXO-GroundStart*. This is the type of signaling done between PBXs. This also sets the signaling type used for each of the virtual circuits across this port.



For PRI signaling, you must set the TC Signaling Type to PLAR when the port is configured for structured voice.

TC1 Signaling Bits / TC2 Signaling Bits (Structured Voice mode only)—Trunk condition 1 and trunk condition 2 signaling bits: onhook or offhook. The default for TC1 Signaling Bits is onhook, while the default for TC2 Signaling is offhook. The default values are usually suitable for PBX applications, but for channel bank applications you should set TC2 Signaling Bits to onhook. For further details about trunk conditioning, see “DS0 Trunk Conditioning” later in this section.

Timing—The type of input clock service configured for the port interface. The default is System. The *SRTS* and *Adaptive* options are normally used for voice applications—*SRTS* for unstructured voice applications and *Adaptive* for structured voice applications.

System—Configures the port interface to use the internal clock as the timing source.

Loop—Configures the port interface to use the input port Rx clock as the timing source; timing is received from the service “loop.” Select *Loop* if the T1-DSX port is used for the network/carrier service termination, in which case the carrier (the service “loop”) typically provides the timing source.

SRTS (unstructured ports only)—Synchronous Residual Time Stamp; a means to measure the service clock frequency against a network-wide synchronization signal. SRTS measures input frequency against the master network clock source and adjusts the line rate by sending residual time stamps in the AAL1 header to the remote end.

Adaptive (unstructured ports only)—A non-required network-wide synchronization technique used to regenerate the input service clock. Adaptive timing uses a buffer depth indicator at the receiver to adjust the line rate: the fuller the buffer, the faster the line rate; the emptier the buffer, the slower the line rate.

Figure 96 illustrates the SRTS and Adaptive timing options.

Figure 96 CBR T1-DSX Timing Options

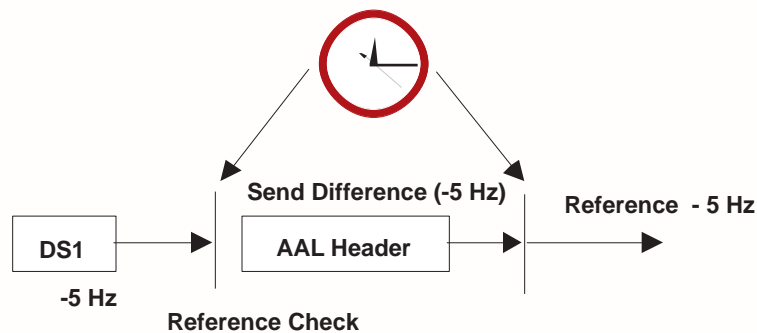

Synchronous Residual Time Stamp (SRTS)

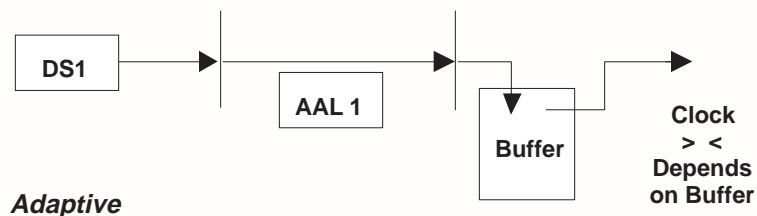

Idle Timer—This parameter applies to the video dial feature. Use it to set the length of time, in seconds (6-60) after which the CBR software shuts off cell transmission and puts the virtual circuit into a listening mode if no cells have been received on a T1-DSX/E1 port connected to an MCU device. If a T1-DSX/E1 port is connected to an MCU device, the bandwidth allocated to the virtual circuits must be saved when a video conference is not in progress. To accomplish this, the CBR software starts an internal timer when no cell is being received. If the amount of time you specify as the *Idle Timer* expires before another cell is received, the software shuts off cell transmission and puts the virtual circuit into a listening mode.

DBA Bits Mask (Structured Data ports only)—Dynamic bandwidth allocation bits mask; a numeric code, in the range 1-255, representing a mask that masks off bits that are not a portion of the idle code. When a DSX-1/E-1 CBR port is configured as structured data, all virtual circuits in the port use a preselected DBA Bits Mask. The decimal number that represents the DBA Bits Mask corresponds to an internal 8-bit value. The default DBA Bits Mask is 127.



The DBA Bits Mask parameter is designed to accommodate situations in which the PathBuilder S330/S310 must communicate with equipment that uses non-standard signaling patterns. In most cases you should leave this parameter set to its default value. If you are experiencing problems with a CCS circuit, however, you may need to set the DBA Bits Mask to a different value. The PathBuilder S330/S310 performance monitoring feature reports the data bytes to the cell bus on the CBR port. You can check this statistic to determine if you need to set a non-default DBA Bits Mask. For details, see “CBR ATM Statistics” in Chapter 5.

CRC-4 (E1 only)—Enables (*yes*) or disables (*no*) Cyclic Redundancy Check 4 (CRC-4) information. CRC-4 is a framing option that checks for errors in data. It is a communication check for parity/framing and is used for performance monitoring in E1 networks. CRC4 can be enabled only in structured and multi-frame mode.

Admin Status—Administrative status: *Out of Service* or *In Service*.

- 5 Select *[10] Previous Menu* to return to the CBR T1-DSX or CBR E1 Configuration Selection menu.
- 6 Repeat steps 3 and 4 for the other CBR T1-DSX or CBR E1 ports you want to configure.

DS0 Trunk Conditioning

When the PathBuilder S330 is powered up, all DS0 channels on the T1 are trunk conditioned, six DS0s at a time. This trunk conditioning readies the PBX for voice communication. It is performed using TC1 signaling bits first and then TC2 signaling bits. The trunk conditioning stays in the each state (TC2 then TC3) for one second. The DS0s that are not assigned to a PBC stay trunk conditioned, forcing the PBX not to use them.

If there is an alarm state or any error condition that will impact traffic, the affected DS0 channels are trunk conditioned using TC1 signaling bits first, and then TC 2 signaling bits. The trunk conditioning stays in the each state (TC1 then TC2) for one second. This trunk conditioning prevents calls from being placed over a bad line.

Configuring the CBR Serial Port

To configure the CBR serial port, follow these steps:

- 1 From the Configuration Management menu, select *[1] Manage Card*.
- 2 From the List Card menu, shown earlier in Figure 51, select *[7] CBR*. The CBR T1-DSX or CBR E1 Configuration Selection menu appears, as shown in above in Figure 93.
- 3 Select *[4] Port 4 (V.35)* to display the CBR T1-DSX/E1 V35 Configuration menu. Figure 97 shows the CBR E1 V35 Configuration menu. The CBR T1-DSX V.35 Configuration menu is the same.

Figure 97 Configuring the CBR Serial Port

```

Telnet - 209.31.3.23
Connect Edit Terminal Help
testnode PathBuilder S330 Alarm Read-Write
Slot#7 Port#4 - CBR E1 V35 Configuration

SCT Clock Source: Internal          Cable ID: None
SCR Clock Source: Internal          RTS CTS DCD DSR: Off Off Off Off
SCTE Clock Source: Echo Clock From DTE Selected DS0 Channels: None
SCTE Clock Phase Control: Normal    DSR Option: Forced On
56K/64K Mode: 64K Mode              CTS&DCD Option: Forced On
Dial Timer: 5 seconds                Admin. Status: Out of Service
Cable Attach Status: Not Attached    Operation Status: Out of Service
Cable Mode: None

1. Set SCT Clock Source              6. Set Dial Timer
2. Set SCR Clock Source              7. Set DSR Option
3. Set SCTE Clock Source             8. Set CTS&DCD Option
4. Set SCTE Clock Phase Control      9. Set Admin. Status
5. Set 56K/64K Mode                 10. Previous Menu

Please enter a selection 1 to 10 [10]: █

```

- 4 Set the following port configuration parameters as desired:

SCT Clock Source—The type of input clock service configured for the port interface.

Recovered—A non-required network-wide synchronization technique used to regenerate the input service clock. Adaptive timing uses a buffer depth indicator at the receiver to adjust the line rate: the fuller the buffer, the faster the line rate; the emptier the buffer, the slower the line rate.

Internal—Configures the port interface to use the internal clock as the timing source.

SCR Clock Source—The type of output clock service configured for the port interface.

Internal—Configures the port interface to use the internal clock as the timing source.

Adaptive—A non-required network-wide synchronization technique used to regenerate the input service clock. Adaptive timing uses a buffer depth indicator at the receiver to adjust the line rate: the fuller the buffer, the faster the line rate; the emptier the buffer, the slower the line rate.

SCTE Clock Source—The Rx timing source for the serial interface: *Echo Clock from DTE or DCE Transmit Clock*.

SCTE Clock Phase Control—Receive timing phase control. This parameter applies only when the attached cable is DCE type cable. Depending on the speed of the device application and the clock phases, particularly those of the return clock, you may have to set SCTE Clock Phase Control to Inverted (invert the clock) to ensure correct clock and data phase.

Normal—The receive timing from the remote endpoint (node) is normal clocking.

Inverted—The receive timing from the remote endpoint (node) is inverted clocking.

56K/64K Mode—The T1 DSU/CSU mode to be emulated: *56k Mode* (n x 56) or *64k Mode* (n x 64).

Dial Timer—The amount of time, in seconds, after which dialing is assumed to be ended if no further digits have been received: 6-60. This parameter applies to the video dial feature. The RS-366 specification does not require all calls to be ended with the EON (End of Number) digit. If no EON is available, the CBR software uses the Dial Timer to determine when dialing is complete. The CBR software resets the timer each time a digit is received. When the timer expires, the dialing is assumed to be completed, and the RS-366 driver forwards the call to the call handling task for further processing.



When used alone, the CBR V.35 interface is used in the lease line environment, and all of the interface signals are forced to on. When used with RS-366, the CBR V.35 interface is used in a switched environment. The DSR and CTS&DCD options allow you to emulate the switched environment by specifying that certain interface signals should go off in alarm conditions.

DSR Option—Specifies the behavior of the DSR interface signal:

Forced On—Force the DSR signal to *on* in all conditions.

Follow DTR—Direct the DSR signal to follow the DTR signal.

Toggle—Toggle the DSR signal *off* for three seconds and then to *on* after the DSC goes *off*.

CTS&DCD Option—Specifies the behavior of the CTS and DCD interface signals:

Forced On—Force the CTS and DCD signals to *on* in all conditions.

Follow DTR—Direct the CTS and DCD signals to follow the DTR signal.

Follow DTR & DSC—Direct the CTS and DCD signals to follow the DTR and DSC signals.

Admin. Status—Administrative status: *In Service* or *Out of Service*.

Configuring the CBR Card

The only type of configuration you can perform on the T1/E1 UNI card is to put it in service or out of service.

To put the T1/E1 UNI card in service or out of service, follow these steps:

- 1 From the Configuration Management menu, select [1] *Manage Card*.
- 2 From the List Card menu, shown earlier in Figure 51, select [7] *CBR*. The CBR T1-DSX or CBR E1 Configuration Selection menu appears, as shown earlier in Figure 93.
- 3 Select [5] *Card Configuration* to display the CBR Card Configuration menu. Figure 98 shows the CBR E1 Card Configuration menu. The CBR t1-DSX Card Configuration menu is the same.

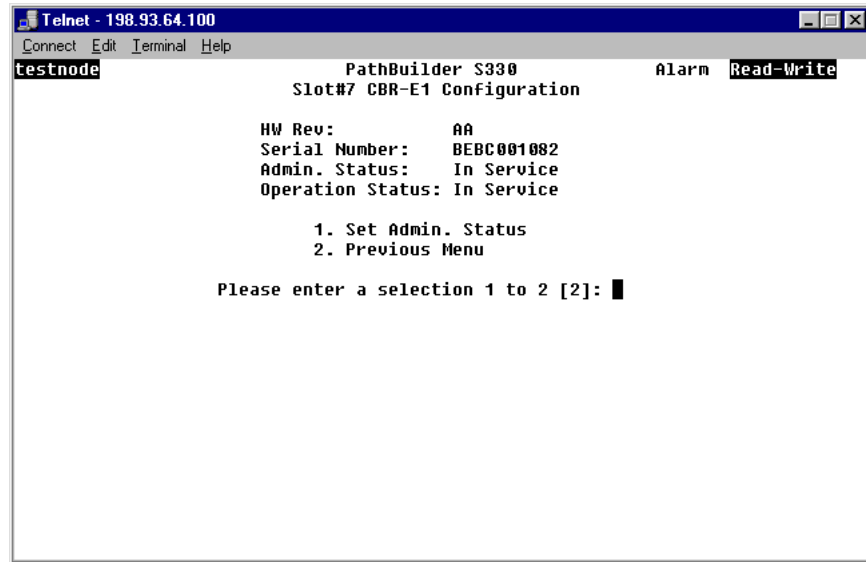
Figure 98 CBR Card Configuration Menu

- 4 Select [1] Set Admin Status and enter 2 to put the CBR card in service or 1 to take it out of service.

Configuring the Voice Compression Module

The optional Voice Compression module (VCM) consists of one T1/E1 interface which you connect to a PBX trunk. The T1/E1 interface's 24/31 DS0 channels can carry individual voice, fax, modem, or data connections—or you can bundle multiple DS0s to provide connections for high-rate applications such as video conference or multiple-link PPP. For CCS, a DS0 is used as an ISDN D-channel for carrying signal messages.

Configuring the VCM involves the following tasks:

- Configuring the channels
- Configuring the T1/E1 port
- Configuring the VCM card

The following subsections describe these tasks. For details about configuring virtual circuits for the VCM, see "Configuring Virtual Circuits" later in this chapter.

Configuring VCM DS0 Channels

To configure VCM DS0 channels, follow these steps:

- 1 From the VCM Configuration menu, shown earlier in Figure 100, select [1] Channel Configuration.

The following prompt appears:

```
Enter Channel (1-8):
```

- 2 Enter the number of the channel you want to configure.

After you enter the channel number, the VCM Channel Configuration menu opens. Figure 99 shows a representative VCM Channel Configuration menu.

Figure 99 VCM Channel Configuration Menu

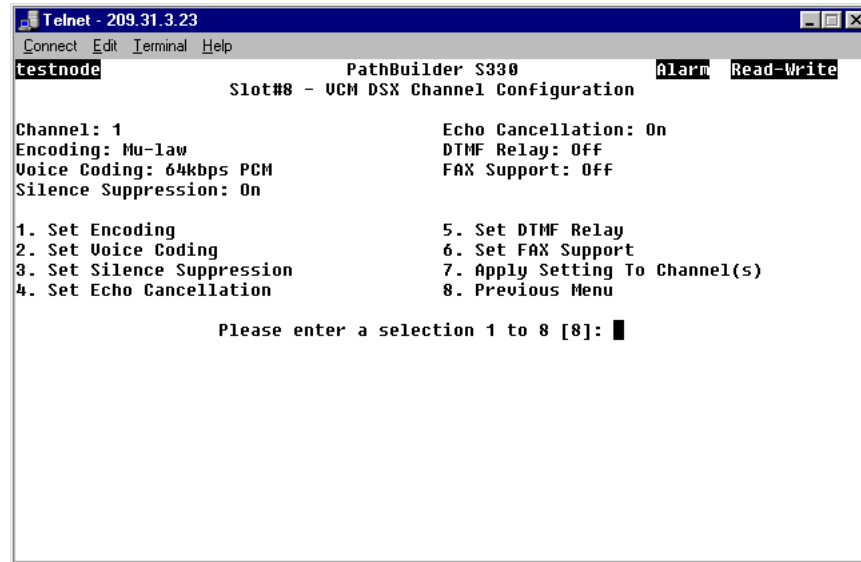

- 3 Set the following channel configuration parameters:

Encoding—Encoding scheme: *A-law* (United States) or *Mu-law* (international).

Voice Coding—Voice compression algorithm: *Clear data*, *64kbps PCM*, *40kbps ADPCM*, *32kbps ADPCM*, *24kbps ADPCM*, *16kbps ADPCM*, or *8kbps G.729A*.

Silence Compression—Enable (*On*) or disable (*Off*) silence compression and comfort noise injection. If you enable *Silence Suppression*, the system will automatically insert comfort noise when it detects silence in the voice transmission.

Echo Cancellation—Enable (*On*) or disable (*Off*) echo cancellation. If you enable *Echo Cancellation*, the DSP will perform up to 16ms echo cancellation.

DTMF Relay—Enable (*On*) or disable (*Off*) DTMF Relay. If you enable *DTMF Relay* the Voice Compression module sends DTMF using a different packet. If you disable *DTMF Relay*, the Voice Compression module simply compresses the voice signal.

FAX Support—Enable (*On*) or disable (*Off*) FAX relay. If you set *FAX Support* to *On*, the system modulates and demodulates the fax and transfers fax data.

- 4 Select [7] *Apply Setting to Channel(s)* to apply your settings to one or more channels. The following prompt appears:

Enter Channel(s) (1-8):

- 5 Enter the number(s) of the channel(s) to which you want to apply the settings. You can enter a single channel, a range of channels (for example: **4-6**), or a list of channels separated by commas (for example: **4, 5, 6**).

Configuring the VCM T1/E1 Port

To configure the VCM T1/E port, follow these steps:

- 1 From the Main menu, select [2] *Configuration Management* to open the Configuration Management menu, shown earlier in Figure 50.
- 2 From the Configuration Management menu, select [1] *Manage Card* to open the List Card menu, shown earlier in Figure 51.

- 3 From the List Card menu, enter the number corresponding to the slot in which the VCM you want to configure is installed (**7** or **8**) to open the VCM Configuration menu. Figure 100 shows the VCM T1-DSX Configuration menu. The VCM E1 Configuration menu is the same.

Figure 100 VCM Configuration Menu

```

Telnet - 209.31.3.23
Connect Edit Terminal Help
testnode PathBuilder S330 Alarm Read-Write
          Slot#8 VCM DSX Configuration

          1. Channel Configuration
          2. Port Configuration
          3. Card Configuration
          4. Previous Menu

          Please enter a selection 1 to 4 [4]: █
  
```

- 4 Select **[2]** *Port Configuration* to open the VCM Port Configuration menu. Figure 101 shows the VCM T1-DSX Port Configuration menu. The VCM E1 Port Configuration menu is similar.

Figure 101 VCM Port Configuration Menu

```

Telnet - 209.31.3.23
Connect Edit Terminal Help
testnode PathBuilder S330 Alarm Read-Write
          Slot#8 Port#1 - VCM DSX Port Configuration

LBO: 330-440 ft          TC1 Signaling Bits: on-hook
Line Code: B8ZS         TC2 Signaling Bits: off-hook
Framing: ESF            Timing: System
Signaling: CAS          Admin. Status: Out of Service
TC Signaling Type: E&M  Operation Status: Out of Service

          1. Set LBO
          2. Set Line Code
          3. Set Framing
          4. Set Signaling
          5. Set TC Signaling Type
          6. Set TC1 Signaling Bits
          7. Set TC2 Signaling Bits
          8. Set Timing
          9. Set Admin. Status
          10. Previous Menu

          Please enter a selection 1 to 10 [10]: █
  
```

- 5 Set the following port configuration parameters.

LBO (T1-DSX only)—Line Build Out. LBO refers to the signal generation/regeneration of the distance between the PathBuilder S330/S310 and the next crossconnect of FOTs (Fiber Optic Terminal system), in feet: 1-110, 110-220, 220-330, 330-440, 440-550, 550-600 or 600+.

Line Code—The zero code suppression technique configured to the VCM T1/E1 port. Set this parameter to match the service provider or device connection line coding. The *Line Code* must match at local and remote ports.

AMI—Alternate mark inversion; a carrier line coding format whereby successive ones (marks) are alternately inverted.

B8ZS (T1-DSX only)—Binary 8 Zero Substitution; a T1 (1.544Mbps) carrier line coding format used to accommodate “ones density” for clear channel transmission.

HDB3 (E1 only)—High Density Bipolar 3; an E1 carrier line coding format. To transmit data and maintain synchronization, E0 transmitters use HDB3 encoding to replace runs of four consecutive zeros.

Framing—The type of frame organization configured for the T1-DSX or E1 port interface: *D4* or *ESF* for VCM T1-DSX; *No Multiframe* or *Multiframe* for VCM E1. Set this parameter to match the service provider or device connection framing. The *Framing* must match at local and remote ports.



CAUTION: *A framing mismatch can cause LOF, OOF alarm conditions and result in traffic loss.*

Signaling—The signaling type configured for the VCM T1/E1 port: *CAS* (channel associated signaling) or *CCS* (common channel signaling).



The TC Signaling Type, TC1 Signaling Bits, and TC2 Signaling Bits parameters are applicable only when Signaling is set to CAS.

TC Signaling Type—The trunk condition signaling type: *PLAR*, *E&MIPLAR*, *FXO-Loop Start*, *FXS-Loop Start*, *FXO-Ground Start*, *FXS-Ground Start*, or *R2-E1*. This is the type of signaling done between PBXs. This also sets the signaling type used for each of the virtual circuits across this port.

TC1 Signaling Bits / TC2 Signaling Bits—Trunk condition 1 and trunk condition 2 signaling bits: onhook or offhook. The default for TC1 Signaling Bits is onhook, while the default for TC2 Signaling is offhook. The default values are usually suitable for PBX applications, but for channel bank applications you should set TC2 Signaling Bits to onhook. For further details about trunk conditioning, see “DS0 Trunk Conditioning” earlier in this chapter.

Timing—The type of input clock service configured for the port interface. The default is *System*.

System—Configures the port interface to use the internal clock as the timing source.

Loop—Configures the port interface to use the input port Rx clock as the timing source; timing is received from the service “loop.” Select *Loop* if the VCM T1/E1 port is used for the network/carrier service termination, in which case the carrier (the service “loop”) typically provides the timing source.

CRC (E1 only)—Enables (*With CRC multiframe*) or disables (*No CRC multiframe*) Cyclic Redundancy Check (CRC) information. CRC is a framing option that checks for errors in data. It is a communication check for parity/framing and is used for performance monitoring in E1 networks.

Admin Status—Administrative status: *Out of Service* or *In Service*.

Configuring the VCM Card

To configure the VCM card, follow these steps:

- 1 From the VCM Configuration menu, shown earlier in Figure 100, select *[3] Card Configuration* to open the VCM Card Configuration menu. This menu lists information about the VCM card and allows you to set the card's administrative status. Figure 102 shows a representative VCM Card Configuration menu.

Figure 102 VCM Card Configuration Menu

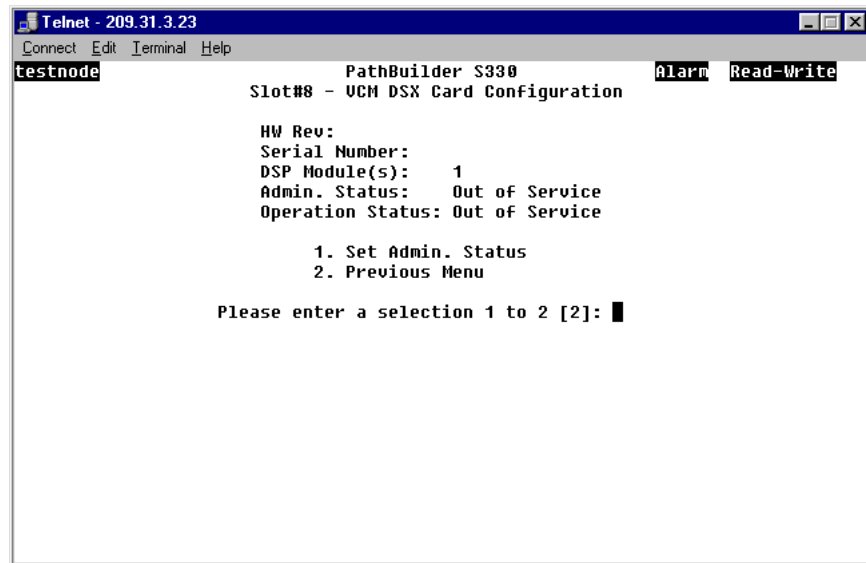

- 2 Select *[1] Set Admin Status* and put the VCM card *In Service* or *Out of Service*.

Configuring Virtual Circuits

Once you have configured the PathBuilder S330/S310's modules and ports, you can start setting up virtual circuits. A virtual circuit is a bi-directional path between data ports of connecting ATM units. You should have a circuit plan developed in advance.

The PathBuilder S330/S310 supports both VPCs (virtual path connections) and VCCs (virtual channel connections). A virtual path is an aggregate collection of virtual channels for the purpose of assigning the channels to a single physical layer. A virtual channel is a connection between data ports.

- You define a VPC at the connecting units by assigning it a Virtual Path Identifier (VPI) for each direction of transmission.
- You define a VCC at the connecting units by assigning it a Virtual Path Identifier (VPI) and a Virtual Channel Identifier (VCI) for each direction of transmission. You can connect one or more virtual circuits to a data port by assigning each a different VPI and VCI. The VPI and VCI numbers are normally assigned as a pair: VPI/VCI.

When you add a virtual circuit, you make a connection from the selected port to for traffic to flow through the PathBuilder S330/S310 and across the ATM WAN service. Typically, the VPI and VCI numbers for one side of the circuit are assigned by the network service provider or local IS administrator—depending on whether your network is a public or private ATM network.

The port VPI/VCI ATM circuit designators must match the application being supported. For example, if an OC3/STM-1 multi-mode fiber module is installed in the Side B slot of the PathBuilder WAN Access Switch and is connected to a LAN ATM switch device, then the Rx VPI/VCI for the ATM LAN interface must match the Tx VPI/VCI for the OC3/STM-1 UNI module and vice versa. This ensures the first step in making the connection into the PathBuilder S330.

Supported Classes of Virtual Circuits

The PathBuilder S330/S310 supports four classes of virtual circuits;

PVC—Standard VP/VCC permanent virtual circuits connecting various type of data ports. For details about setting up PVC virtual circuits, see “Adding PVC Virtual Circuits” later in this chapter.

RS366 Template—Video-associated virtual circuit templates. When the circuit defined by an RS366 template is activated, it supports dialed video conferencing over an ATM network. For details setting up RS-366 virtual circuit templates, see “Defining RS366 (Video) Virtual Circuit Templates” later in this section.

VCM VCC—Voice Compression module VCC virtual circuits. VCM VCC circuits carry individual voice, fax, modem, or data connections. For details about setting up VCM VCC circuits, see “Adding Voice Compression Module VCC Circuits” later in this chapter.

VCM Subchannel—Voice Compression module subchannel circuits. VCM subchannel circuits carry multiple voice samples from a single DS0 and/or voice samples from multiple DS0s, thereby providing connections for high-rate applications such as video conference or multiple-link PPP. For details about setting up subchannel circuits, see “Adding VCM Subchannel Circuits” later in this chapter.

Adding Virtual Circuits

To define a virtual circuit, follow these steps:

- 1 From the Configuration Management menu, select [2] *Manage Circuit* to display the Virtual Circuit Menu, shown in Figure 103.

Figure 103 Virtual Circuit Menu

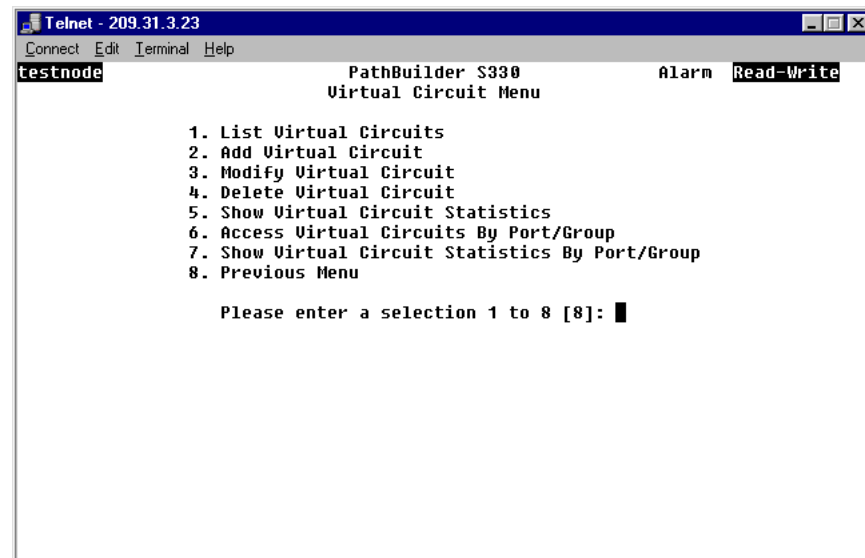

- 2 Select [2] *Add Virtual Circuit*. The Add Virtual Circuit screen appears as shown in Figure 104.

Figure 104 Initial Add Virtual Circuit Screen

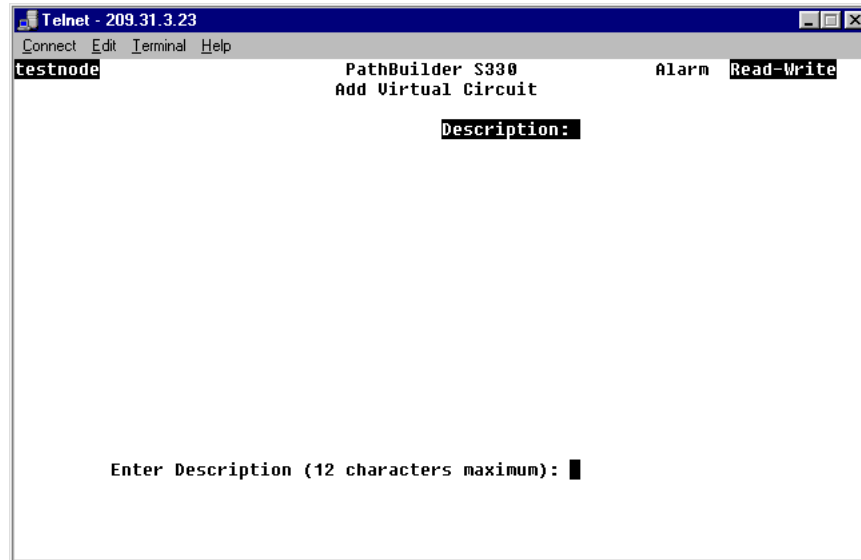

- 3 Enter a description for the virtual circuit you are defining.



We recommend that you do not use the description <366 call>. This is the default description that the system assigns to video virtual circuits when they are activated.

A second screen appears. As shown in Figure 105, the description you entered appears at the top of the screen, and a prompt at the bottom of the screen asks you to select the virtual circuit class: *PVC*, *RS366 Template*, *VCM VCC*, or *VCM Subchannel*. For descriptions of the available VC classes, see “Supported Classes of Virtual Circuits” earlier in this section.

Figure 105 Selecting the Virtual Circuit Class:

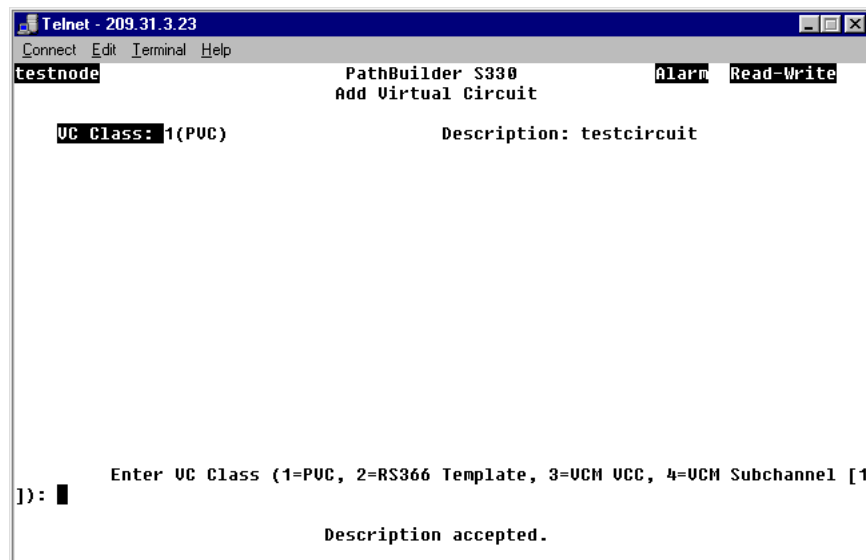

- 4 Enter the number corresponding to the class of virtual circuit you want to define.
 - If you want to create a standard VPC/VCC permanent virtual circuit to connect data ports, select [1] *PVC* and follow the instructions under “Adding PVC Virtual Circuits”.
 - If you want to create a virtual circuit to support video conferencing, select [2] *RS366 Template* and follow the instructions under “Defining RS366 (Video) Virtual Circuit Templates”.
 - If you want to create a VCC virtual circuit to connect VCM ports, select [3] *VCM VCC* and follow the instructions under “Adding Voice Compression Module VCC Circuits”.
 - If you want to create a VCM subchannel circuit that bundles multiple DSOs, select [4] *VCM Subchannel* and follow the instructions under “Adding VCM Subchannel Circuits”.

Adding PVC Virtual Circuits

To configure a VPC/VCC virtual circuit to connect data ports, follow these steps:

- 1 When you are prompted to select the virtual circuit type, as shown earlier in Figure 105, enter **1** to create a *PVC* circuit.

As shown in Figure 106, you are prompted to select a virtual circuit type.

Figure 106 Selecting the PVC Virtual Circuit Type: VCC or VPC

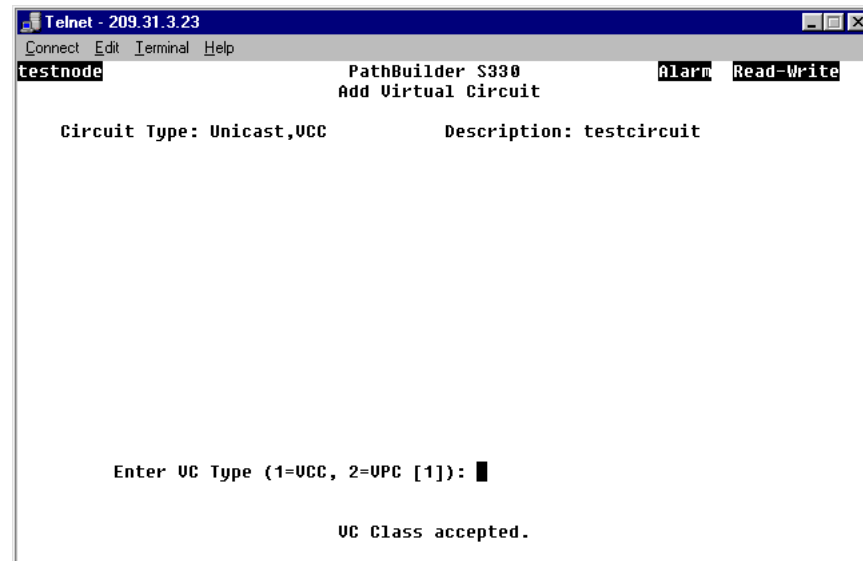

- 2 Enter the number corresponding to the type of virtual circuit you want to configure:

VCC (virtual channel connection)—You can use this connection type for circuit between non-UNI and UNI cards and between UNI and UNI cards; both the VPIs and the VCIs will be translated.

VPC (virtual path connection)—You can use this connection type only for circuits between UNI and UNI cards; only the VPIs will be translated.



To operate a circuit as a VP, set the connection type to VPC.

A screen appears, listing the PathBuilder S330/S310 modules and ports by slot number and prompting you to select a slot for side A, as shown in Figure 107.

Figure 107 Selecting a Slot for Side A of the Virtual Circuit

- 3 Enter the slot number for the module that you want to define as side A of the virtual circuit. For example, to assign the SIM card as side A, you would enter **5**.



The default slot number is indicated by an asterisk. To select the default slot number, simply press [Enter].

After you enter the slot number, the Add Virtual Circuit screen displays the selected slot number and port type, lists the parameters you will enter for side A of the circuit, and prompts you to set the first parameter. The parameters listed vary, depending on the type of port you selected. See “Virtual Circuit Parameters”, later in this section, for parameter descriptions.



You can also create an in-band circuit between two nodes by defining the PathBuilder S330/S310 MCU—with its own IP address—as one side of the virtual circuit. This enables you to manage a remote hub from a local network management station. See “Configuring In-band Management” in Chapter 3, for details.

- 4 Follow the prompts that appear at the bottom of the screen, pressing [Enter] after each entry. Default values are listed in square brackets ([]) at the end of each prompt.



Your settings are added to list of parameters at the top of the screen as you enter them. You must enter a setting for all the parameters for which you are prompted in order to add a circuit. Press [Delete] to back up to a previous selection.

When you have entered a setting for each parameter, the Add Virtual Screen again displays the list of PathBuilder S330/S310 modules and ports by slot number and prompts you to enter a slot number for side B of the circuit, as shown in Figure 108.

Figure 108 Add Virtual Circuit Screen with Side A Completed

```

Telnet - 209.31.3.23
Connect Edit Terminal Help
testnode PathBuilder S330 Alarm Read-Write
Add Virtual Circuit

Circuit Type: Unicast,UCC          Description: testcircuit

SIDE A                               SLOT CARD
Slot/Port/Card: 7/1/CBR-E1(3)/U35   * 3 DS1
CDU Buffer Size: 1 ms                 4 OC3
Cell Loss Integ Period: 2500 ms      7 CBRE
Payload Size/Type: 47 bytes/voice
Onhook Detection: 1(Disabled)
Signaling Type: 7(R2)
Tel Channels: 1
Priority: 0
Early Packet Discard: 1(no)

Enter Side B Slot ([3]): █

Priority accepted.

```



Some parameters that appear on the Add Virtual Circuit screen may not apply to the particular circuit you are configuring. The system skips any non-applicable parameters and does not allow you to set them. In addition, certain parameters may be displayed for information only; you cannot change these read-only values.

- 5 Select the slot number corresponding to the module by which you are connected to the network for side B of the circuit.
- 6 Repeat steps 3 and 4 for side B of the circuit. After you enter the last parameter for side B, the following prompt appears at the bottom of the screen:

```
Enter Admin. Status (1=out of service, 2=in service [2]):
```
- 7 Set the administrative status for the circuit. The following prompt appears at the bottom of the screen:

```
Is the above information correct (y/n)?
```
- 8 Enter **y** to confirm your configuration. Figure 109 shows a completed data port VCC circuit. As shown in the figure, the following message appears at the bottom of the screen:

```
VC has been added.
Press any key to continue.
```

Figure 109 Completed Data Port VCC Virtual Circuit

```

Telnet - 198.93.64.100
Connect Edit Terminal Help
testnode PathBuilder S330 Alarm Read-Write
Add Virtual Circuit

Circuit Type: Unicast,UCC          Description: testcircuit5
Admin. Status: 2(in service)
SIDE A                               SIDE B
Slot/Port/Card: 7/1/CBR-E1(3)/U35  Slot/Port/Card: 4/OC3 UNI
CDU Buffer Size: 1 ms                Receive UPI/UCI: 0/4
Cell Loss Integ Period: 2500 ms      Transmit UPI/UCI: 0/4
Payload Size/Type: 47 bytes/voice     Priority: 0
Onhook Detection: 1(Disabled)         Early Packet Discard: 1(no)
Signaling Type: 7(R2)
Tel Channels: 2
Priority: 0
Early Packet Discard: 1(no)

Enter Admin. Status (1=out of service, 2=in service [2]):

UC has been added.
Press any key to continue.

```

- 9 Press any key to return to the Virtual Circuit menu.

Configuring CBR Circuits for DBA

This section provides guidelines for configuring CBR circuits for various types of dynamic bandwidth allocation (DBA)—both for CAS (channel associated signaling) and CCS (common channel signaling applications). Table 25 summarizes the key CBR port and virtual circuit parameters for these types of applications. For details about how DBA works, see “DS0 Signaling and Dynamic Bandwidth Allocation” in Appendix B.

Table 25 CBR Port and Circuit Settings for CAS versus CCS

Parameter	Setting for CAS	Setting for CCS
Port Mode	Structured Voice	Structured Data
Port Data Bits Mask	N/A	Leave at default setting (127) in most cases; for details see “Checking the Data Bytes to Determine a DBA Bits Mask Setting” after this table
VC Payload Size/Type	Voice	Set automatically when VC Mode set to DBA
VC Onhook Detection	Enabled	Set automatically when VC Mode set to DBA
VC Mode	N/A	DBA for channels 1-23 (DSX-1) or 1-15 and 17-31 (E1) Normal for channel 24 (DSX-1) or 16 (E1)

Checking the Data Bytes to Determine a DBA Bits Mask Setting CCS monitors for voice activity. In most cases the default *DBA Bits Mask* (127) works, but if you are having a problem with a CCS circuit, you can set the *DBA Bits Mask* to monitor any bits. The unit will monitor the virtual circuit, and you can use the activity reported on the channel (reported under CBR ATM statistics as *Data Bytes To*) to determine the proper *DBA Bits Mask*. For details about checking the data bytes, see “CBR ATM Statistics” in Chapter 5.

Configuring CBR Circuits for Structured Voice DBA (CAS) In structured voice DBA, the CBR software reads the stored signaling bits and releases bandwidth when it detects an on-hook (idle) condition. Use structured voice circuits with DBA for CAS (channel associated signaling) applications.

To configure a CBR virtual circuit for structured voice DBA, follow these basic steps:

- 1 Configure the CBR port as follows:
 - Set the *Port Mode* to *Structured Voice*.
 - Set the other port parameters as appropriate for your application.
- 2 Configure the CBR virtual circuit as follows:
 - Set the *Payload Size/Type* to *Voice*.
 - Set *Onhook Detection* to *Enabled*.
 - Set the other circuit parameters as appropriate for your application.

Configuring CBR Circuits for Clear Channel Signaling Due to rob-bit signaling, each T1 DS0 channel can have only up to 56 Kbps of bandwidth.

To create a full 64 Kbps DS0 clear channel, follow these basic steps:

- 1 Configure the CBR port as follows:
 - Set the *Port Mode* to *Structured Voice*.
 - Set the other port parameters as appropriate for your application.
- 2 Configure the T1 CBR virtual circuit as follows:
 - Set the *Payload Size/Type* to *Data*.
 - Set *Onhook Detection* to *Disabled*.
 - Set the other circuit parameters as appropriate for your application.

Configuring CBR Circuits for Structured Data DBA (CCS) In structured data DBA, the CBR software reads the DS0 payload bytes and releases bandwidth when it detects an on-hook (idle) condition. Use structured data circuits with DBA for CCS (common channel signaling) applications.

To configure a CBR virtual circuit for structured data DBA, follow these basic steps:

- 1 Configure the CBR port as follows:
 - Set the *Port Mode* to *Structured Data*.
 - Set the other port parameters as appropriate for your application.
- 2 Configure the CBR circuit as follows:
 - Set the *Mode* to *DBA*.
 - Set the other circuit parameters as appropriate for your application.



The Payload Size/Type, Onhook Detection and Signaling Type parameters are set automatically when you set the circuit Mode to DBA.

Setting up a PRI PBX Tie Line PRI signaling is a type of CCS in which one channel (24) is used to signal for the other channels (1-23). This is in contrast to CAS in which signaling is done on all channels.

To set up a PRI PBX tie line, follow these basic steps:

- 1 Configure the CBR port as follows:
 - Set the *Port Mode* to *Structured Data*.
 - Set the other port parameters as appropriate for your application.
- 2 Configure the CBR circuits as follows:
 - For channel 24, set the *Mode* to *Normal*.
 - For channels 1-23, set the *Mode* to *DBA*.
 - Set the other circuit parameters as appropriate for your application.

Defining RS366 (Video) Virtual Circuit Templates

The RS366 video dial feature uses CBR virtual circuits to support dialed video conferencing over an ATM network. The feature works as follows:

- To set up RS366 virtual circuit *templates*, you follow the same basic procedure that you do to add PVC virtual circuits (see “Adding Virtual Circuits” for details). The RS-366 (video) templates are identified as such when you select *RS366 Template* (rather than *PVC*) as the *VC Type* (see step 4 under “Adding Virtual Circuits”). Before you can make a video call, you must set up an RS366 virtual circuit template.
- You can define as many templates as you want to connect to different destinations.
- When the phone number associated with a given template is dialed, the PathBuilder S330/S310 software locates the template and uses it to create a temporary virtual circuit to which it assigns the default description *<366 call>*.



A video connection is established either via the Manual Connect A Site menu, as described in “Managing Video Dial-up Sessions” later in this chapter, or when someone dials the phone number associated with the video circuit on a video keypad.

- Data for the video conference is transmitted and received over the newly-created *<366 call>* circuit.
- When the call is disconnected, the system deletes the *<366 call>* circuit, but preserves the template upon which the circuit was based for future use.

For further details about video conferencing and information on setting up call routing tables for *point-to-point video conferencing* (between remote PathBuilder S330/S310 switches) and *multi-point video conferencing* (both between remote PathBuilder switches and between a central PathBuilder S330/S310 and remote PathBuilder S330/S310 switches) see “Video Conferencing” in Appendix B.



Since only one video virtual circuit is active at any given time, you must build multiple video-associated virtual circuits—even though they use the same physical port and T1/E1 channels.

To define an RS366 (video) virtual circuit template, follow these steps:

- 1 When you are prompted to select the virtual circuit type, as shown earlier in Figure 105, select [2] *RS366 Template*.

As shown in Figure 110, the screen lists the slot in which the CBR module is installed, and you are prompted to enter that slot number.

Figure 110 Selecting the Slot for Side A of a Video Virtual Circuit Template

```
Telnet - 209.31.3.23
Connect Edit Terminal Help
testnode PathBuilder S330 Alarm Read-Write
Add Virtual Circuit

Circuit Type: RS366 Template Description: testcircuit2

SLOT CARD
-----
* 7 CBR

Enter Side A Slot ([7]): 7

UC Class accepted.
```

- 2 Enter the appropriate slot number.

The screen lists the Slot/Port/Card you have selected, and you are prompted to enter the port number of the CBR module port from which you want to build the video circuit, as shown in Figure 111.

Figure 111 Selecting the CBR Module Port for Side A of a Video Virtual Circuit

```
Telnet - 209.31.3.23
Connect Edit Terminal Help
testnode PathBuilder S330 Alarm Read-Write
Add Virtual Circuit

Circuit Type: RS366 Template Description: testcircuit2

CBR SIDE
Slot/Port/Card: 7/1/CBR-E1(3)/035

Enter Side A Port (1..4 [1]): 1

Slot accepted.
```

- 3 Enter the desired port number.
 - If you are setting up point-to-point video conferencing (between remote PathBuilder S330/S310 switches).
 - Enter **4** to select the serial (V.35) port.
 - If you are setting up multi-point video conferencing (both between remote PathBuilder S330/S310 switches and between remote PathBuilder S330/S310 switches and a central PathBuilder S330/S310 switch).
 - For the remote units, enter **4** to select the CBR serial (V.35) port.
 - For the central unit, enter **1**, **2**, or **3** to select one of the CBR T1-DSX/E1 ports.

The Add Virtual Circuit screen lists the parameters you will enter for side A of the circuit template and prompts you to set the first parameter. See “CBR Module Virtual Circuit Parameters”, later in this chapter, for parameter descriptions.

- 4 Follow the prompts that appear at the bottom of the screen, pressing [Enter] after each entry.



Your settings are added to list of parameters at the top of the screen as you enter them. You must enter a setting for all the parameters for which you are prompted in order to add a circuit template. Press [Delete] to back up to a previous selection.

When you have completed side A of the circuit template by entering a setting for each parameter, the Add Virtual Circuit screen displays a list of PathBuilder S330/S310 modules that you can use for side B of the circuit template.

Figure 112 shows the Add Virtual Circuit screen with side A completed for a video virtual circuit template using the CBR serial port. Figure 113 shows the Add Virtual Circuit screen with side A completed for a virtual circuit template using a CBR T1-DSX/E1 port.

Figure 112 Side A Completed for Video Virtual Circuit Using CBR Serial Port

```

Telnet - 209.31.3.23
Connect Edit Terminal Help
testnode PathBuilder S330 Alarm Read-Write
Add Virtual Circuit

Circuit Type: RS366 Template      Description: testcircuit2
CBR SIDE                        SLOT CARD
Slot/Port/Card: 7/4/CBR-E1(3)/U35  -----
CDU Buffer Size: 1 ms              * 3 DS1
Cell Loss Integ Period: 2500 ms    4 OC3
Payload Size/Type: 47 bytes/data
Onhook Detection: 1(Disabled)
Signaling Type: No Signaling
V.35 Bandwidth: 24 x 64K
Phone#: 535-2345
Priority: 0
Early Packet Discard: 1(no)

Enter Side B Slot ([3]): █

Priority accepted.

```

Figure 113 Side A Completed for Video Virtual Circuit Using CBR T1-DSX/E1 Port

```

Telnet - 209.31.3.23
Connect Edit Terminal Help
testnode PathBuilder S330 Alarm Read-Write
Add Virtual Circuit

Circuit Type: RS366 Template      Description: testcircuit3

CBR SIDE                          SLOT CARD
Slot/Port/Card: 7/1/CBR-E1(3)/U35  * 3 DS1
CDU Buffer Size: 1 ms              4 OC3
Cell Loss Integ Period: 2500 ms
Payload Size/Type: 47 bytes/voice
Onhook Detection: 1(Disabled)
Signaling Type: 7(R2)
Tel Channels: 1
Phone#: 535-2347
Priority: 0
Early Packet Discard: 1(no)

Enter Side B Slot ([3]): █

Priority accepted.

```

- 5 Select the slot number corresponding to the module by which you are connected to the network for side B of the circuit template.
- 6 Repeat steps 3 and 4 for side B of the circuit template. After you enter the last parameter for side B, the following prompt appears at the bottom of the screen:

Is the above information correct (y/n)?

- 7 Enter **y** to confirm your configuration. The following message appears at the bottom of the screen:

VC has been added.

Press any key to continue.

Figure 114 shows a completed video virtual circuit template. When the phone number 555-2345 is dialed, the circuit that this template defines will be activated.

Figure 114 Completed RS366 (video) Virtual Circuit Template

```

Telnet - 209.31.3.23
Connect Edit Terminal Help
testnode PathBuilder S330 Alarm Read-Write
Add Virtual Circuit

Circuit Type: RS366 Template      Description: testcircuit2

CBR SIDE                          UNI SIDE
Slot/Port/Card: 7/4/CBR-E1(3)/U35  Slot/Group/Card: 3/1/DS1 UNI (4)
CDU Buffer Size: 1 ms              Receive UPI/UCI: 0/2
Cell Loss Integ Period: 2500 ms    Transmit UPI/UCI: 0/2
Payload Size/Type: 47 bytes/data    Priority: 0
Onhook Detection: 1(Disabled)       Early Packet Discard: 1(no)
Signaling Type: No Signaling
U.35 Bandwidth: 24 x 64K
Phone#: 535-2345
Priority: 0
Early Packet Discard: 1(no)

Enter Side B Priority (0(high)..3(low) [0]):

UC has been added.
Press any key to continue.█

```

- 8 Press any key to return to the Virtual Circuit menu.

Adding Voice Compression Module VCC Circuits

To configure a VPC/VCC virtual circuit to connect data ports, follow these steps:



You must configure at least one VCM VCC circuit before you can configure any VCM subchannel circuits.

- 1 When you are prompted to select the virtual circuit type, as shown earlier in Figure 105, enter **3** to create a VCM VCC circuit.

A screen appears, listing the modules available to assign as side A of the virtual circuit, as shown in Figure 108.

Figure 115 Selecting a Slot for Side A of a VCM VCC Virtual Circuit

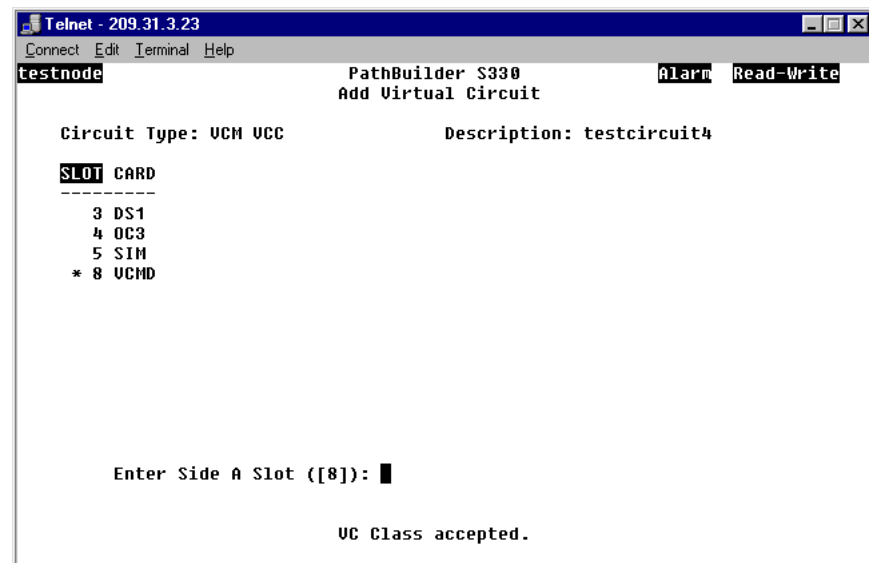

- 2 Enter the number corresponding to the slot in which the Voice Compression module is installed (**7** or **8**) to assign the VCM to side A of the circuit.

The Add Virtual Circuit screen displays the selected slot number and port type, lists the parameters you will enter for side A of the circuit, and prompts you to set the first parameter, as shown in Figure 116.

- 3 Follow the prompts that appear at the bottom of the screen, pressing [Enter] after each entry. Default values are listed in square brackets ([]) at the end of each prompt.



Your settings are added to list of parameters at the top of the screen as you enter them. You must enter a setting for all the parameters for which you are prompted in order to add a circuit. Press [Delete] to back up to a previous selection.



CAUTION: For voice compression circuits, select the Shaper Number corresponding to the maximum shaper value (typically Shaper Number 15).



Make sure that Early Packet Discard is disabled (set to no) for voice compression circuits.

Figure 116 Configuring Side A of A VCM VCC Virtual Circuit

```

Telnet - 209.31.3.23
Connect Edit Terminal Help
testnode PathBuilder S330 Alarm Read-Write
Add Virtual Circuit

Circuit Type: UCM VCC Description: testcircuit4

SIDE A
Slot/Port/Card: 8/UCM-DSX/ENHANCED
Shaper Number: 1(56K/784K)
Priority:
Early Packet Discard:

Enter Shaper Number (1=56K/784K,2=112K/784K,3=224K/784K,
4=448K/784K,5=673K/784K,6=1.35M/1.35M,7=1.49M/1.49M,
8=1.53M/1.53M,9=1.92M/1.92M,10=2.38M/2.38M,11=4M/4M,
12=6.06M/6.06M,13=8M/8M,14=10M/10M,15=16.66M/16.66M [1]):

```

When you have entered a setting for each parameter, the Add Virtual Screen again displays the list of PathBuilder S330/S310 modules and ports by slot number and prompts you to enter a slot number for side B of the circuit, as shown in Figure 117.

Figure 117 VCM VCC Add Virtual Circuit Screen with Side A Completed

```

Telnet - 209.31.3.23
Connect Edit Terminal Help
testnode PathBuilder S330 Alarm Read-Write
Add Virtual Circuit

Circuit Type: UCM VCC Description: testcircuit4

SIDE A
Slot/Port/Card: 8/UCM-DSX/ENHANCED
Shaper Number: 1(56K/784K)
Priority: 1
Early Packet Discard: 1(no)

SLOT CARD
-----
* 3 DS1
  4 OC3
  5 SIM
  8 UCMD

Enter Side B Slot ([3]):

Early Packet Discard accepted.

```

- 4 Select the slot number corresponding to the module by which you are connected to the network for side B of the circuit.
- 5 Repeat steps 3 and 4 for side B of the circuit. The following prompt appears at the bottom of the screen:
Is the above information correct (y/n)?
- 6 Enter **y** to confirm your configuration. Figure 118 shows a completed VCM VCC circuit. As shown in the figure, the following message appears at the bottom of the screen:
VC has been added.
Press any key to continue.

Figure 118 Completed VCM VCC Virtual Circuit

```

Telnet - 209.31.3.23
Connect Edit Terminal Help
testnode PathBuilder S330 Alarm Read-Write
Add Virtual Circuit

Circuit Type: VCM VCC Description: testcircuit4

SIDE A Slot/Port/Card: 8/UCM-DSX/ENHANCED SIDE B Slot/Group/Card: 3/1/DS1 UNI (4)
Shaper Number: 1(56K/784K) Receive UPI/UCI: 0/5
Priority: 1 Transmit UPI/UCI: 0/5
Early Packet Discard: 1(no) Priority: 3
Early Packet Discard: 1(no)

Enter Side B Early Packet Discard (1=no, 2=yes [1]):

UC has been added.
Press any key to continue.

```

- 7 Press any key to return to the Virtual Circuit menu.

Adding VCM Subchannel Circuits

To configure a VCM subchannel circuit, follow these steps:



You must configure at least one VCM VCC circuit before you can configure any VCM subchannel circuits.

- 1 When you are prompted to select the virtual circuit class, as shown earlier in Figure 105, select [4] VCM Subchannel.

A screen similar to the one shown in Figure 119 appears. This screen lists the currently-configured VCM VCC circuits.

Figure 119 Selecting a VCM VCC to Use for a VCM Subchannel Circuit

```

Telnet - 209.31.3.23
Connect Edit Terminal Help
testnode PathBuilder S330 Alarm Read-Write
Add Virtual Circuit

UC# Side A card s/p rx tx Side B card s/p rx tx Description
-----
1 UCMD 8 DS1 3/1 0/1 0/1 testcircuit1
2 UCMD 8 DS1 3/1 0/4 0/4 vcmUCC
3 UCMD 8 DS1 3/1 0/5 0/5 testcircuit

Enter item# (1..3),
ESC for previous menu:

```

- Enter the number corresponding to the VCM VCC circuit upon which you want to base the subchannel circuit to open the VCM Subchannel Add Virtual Circuit screen, shown in Figure 120.

Figure 120 Configuring a VCM Subchannel Circuit

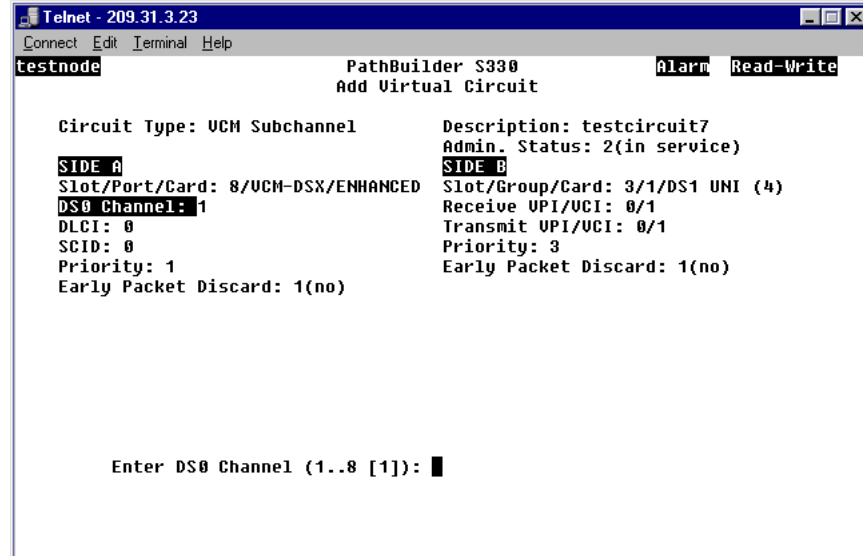

The VCM Subchannel Add Virtual Circuit screen lists the parameters for the selected VCM VCC circuit and prompts you to configure the subchannel parameters.



Make sure that Early Packet Discard is disabled (set to no) for voice compression circuits.

- Set the VCM subchannel circuit parameters, including the following:
 - DS0 Channel**—The number of the DS0 channel you want to assign to the DLCIs used by the circuit.



Since all subchannel values must be unique, it is easiest to use the same VCC and DLCI and to increment the subchannel ID (SCID).

DLCI—Enter the number of the DLCI to be used for the circuit: 16-1023.



Messages appear at the bottom of the screen after you enter the DS0 Channels and DLCI parameters, indicating that your entries have been accepted. If you do not see such a message, the system has not accepted your entry.

SCID—Subchannel ID; the ID number of the subchannel you want to assign to the DS0s used by the circuit: 4-255. After you have entered the subchannel parameters, the following prompt appears at the bottom of the screen:

```
Is the above information correct (y/n)?
```



The DLCI and SCID numbers must match for the local PathBuilder S330/S310 and the remote PathBuilder S330/S310.

- Enter **y** to confirm your configuration. shows a completed VCM subchannel circuit. As shown in the figure, the following message appears at the bottom of the screen:

```
VC has been added.
Press any key to continue.
```

Figure 121 Completed VCM Subchannel Circuit

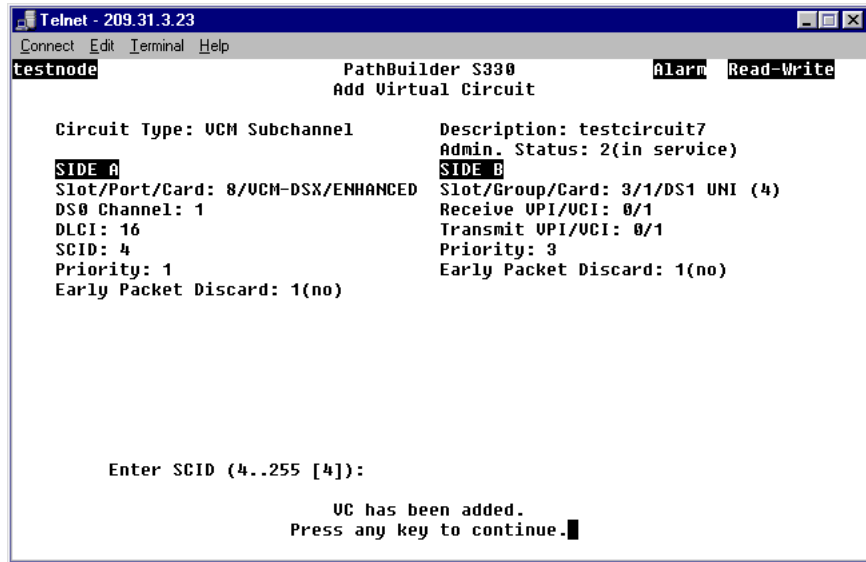

- 5 Press any key to return to the Virtual Circuit menu.

VCM Subchannel Virtual Circuit Example

The following example shows how you can set up a three-node VCM network by creating all required VCM VCC circuits and VCM subchannel circuits. Figure 122 illustrates this setup.

Figure 122 Three-Node VCM Network and Associated Virtual Circuits

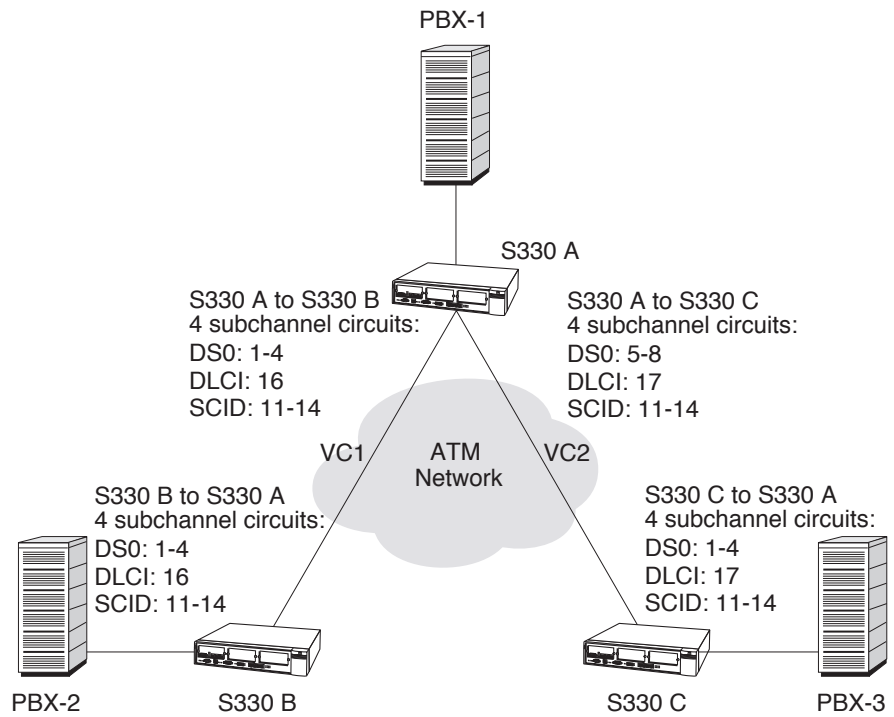

For the purposes of this example, assume you want to make the following connections:

- Connect subchannels 1-4 on PBX-1 to subchannels 1-4 on PBX-2
- Connect subchannels 5-8 on PBX-1 to subchannels 1-4 on PBX-3.

You need to build the following VCM VCC and subchannel circuits:

At PathBuilder S330 A (S330 A):

- Add a virtual circuit (VC 1) between S330 A and S330 B.
- Add a virtual circuit (VC 2) between S330 A and S330 C.
- Add four subchannel circuits to VC 1, setting the VCM circuit parameters as follows:
 - DS0: 1-4
 - DLCI:16
 - SCID: 11-14
- Add four subchannel circuits to VC 2, setting the VCM circuit parameters as follows:
 - DS0: 5-8
 - DLCI:17
 - SCID: 11-14

At PathBuilder S330 B (S330 B):

- Add a virtual circuit (VC 1) between S330 B and S330 A.
- Add four subchannel circuits to VC 1, setting the VCM circuit parameters as follows:
 - DS0: 1-4
 - DLCI:16
 - SCID: 11-14

At PathBuilder S330 C (S330 C):

- Add a virtual circuit (VC 2) between S330 C and S330 A.
- Add four subchannel circuits to VC 2, setting the VCM circuit parameters as follows:
 - DS0: 1-4
 - DLCI:17
 - SCID: 11-14

Virtual Circuit Parameters

The following subsections describe parameters you must enter when you configure virtual circuits for different port types.

Common Virtual Circuit Parameters

The following parameters are common to most port types:

Slot/Port or Group/Card—The slot number, port or IMA group number, and card type.

Shaper Number—The number corresponding to the SAR shaper you want to assign to this circuit. You define the fifteen available shapers from the MCPU Shapers screen. See “Configuring MCPU Shapers” earlier in this chapter, for details.

Priority—The priority level: *high* or *low* (MCPU, OC3/STM-1, QSIM/HSIM/FAM, Ethernet, CBR, VCM); *high*, *medium*, *low1*, or *low2* (T1/E1 UNI).

Early Packet Discard—Enables (*yes*) or disables (*no*) early packet discard. For every connection where early packet discard is enabled, a status is kept when there is a partial packet for that connection in the queue. Once the queue cell level exceeds the *Congestion On* thresholds, only connections with partial packets already existing in the queue are allowed in. Cells from other connections are dropped. Once the congestion has subsided to the *Congestion Off* level, then all remaining connections are allowed.



CAUTION: Do not enable early packet discard for AAL1 traffic.

MCPU Virtual Circuit Parameters

IP Address—The IP address for the PathBuilder S330/S310.

Subnet Mask—The subnet mask for the PathBuilder S330/S310.

T1/E1 UNI Port Virtual Circuit Parameters

Receive VPI/VCI—The VPI/VCI of cells received by the T1/E1 port.

Transmit VPI/VCI—The transmit VPI/VCI of cells transmitted by the T1/E1 port.

OC3/STM-1 Port Virtual Circuit Parameters

Receive VPI—The VPI of cells received by the OC3/STM-1 port.

Transmit VPI/VCI—The transmit VPI/VCI of cells transmitted by the OC3/STM-1 port.

Serial Port Virtual Circuit Parameters

You build connections from the local Ethernet port to a remote Ethernet port by adding Permanent Virtual Circuits (PVCs). These connections allow the packets to be transmitted through the ATM network to the destination port.

The parameters that appear on the Add Virtual Circuit screen vary, depending on the configuration of the serial port that is being connected: Frame Relay, DXI, or SDLC.



The configuration of the card you select on the List Card menu sets the attribute selection for the virtual circuit configuration parameters. If you configure a virtual circuit and then change serial port attributes—from DXI to Frame Relay or vice versa—the circuit will be deleted.

Frame Relay Virtual Circuit Parameters If the serial port is configured as a Frame Relay port, you must set the following virtual circuit parameters in addition to the common *Shaper Number*, *Priority*, and *Early Packet Discard* parameters:

Interworking Mode—The Frame Relay/ATM interworking mode: *Network* or *Service*.

Start/End Frame Relay DLCI—The starting and ending Frame Relay data link connection identifiers: 16...991. These DLCIs are used to identify a Frame Relay local connection. This parameter applies only if the *Interworking Mode* is set to *Network*.

Encapsulation Mode—The encapsulation data goes around the data packet and is used to identify the packet; enter **1** (Transparent) or **2** (Translation).

Transparent—This mode is used for point-to-point frame relay interconnection. See Figure 123. Frame Relay Forum 8 (FRF.8) Service Interworking for this is being implemented. There are two modes at which FRF.8 specifies a mode which is transparent and is in fact 1490 over ATM.

Translation—This mode is used in cases when you have ATM devices that do not support 1490 as a protocol across their ATM trunks; for example, when you have a PathBuilder S330/S310 terminating the ATM network at one end and an ATM-ready device, such as a router with an OC-3 UNI, at the other end. Typically these ATM-ready devices do not support 1490 as a protocol across their ATM trunks, so you have to do LLC_SNAP (1483) per FRF.8. Mode 1F does 1490 to 1483 translation. See Figure 124.

Figure 123 FRF.8 Transparent Encapsulation Mode

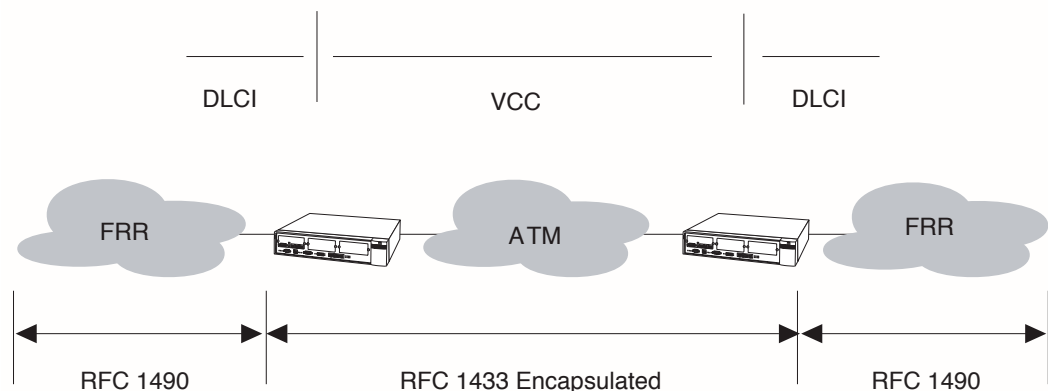
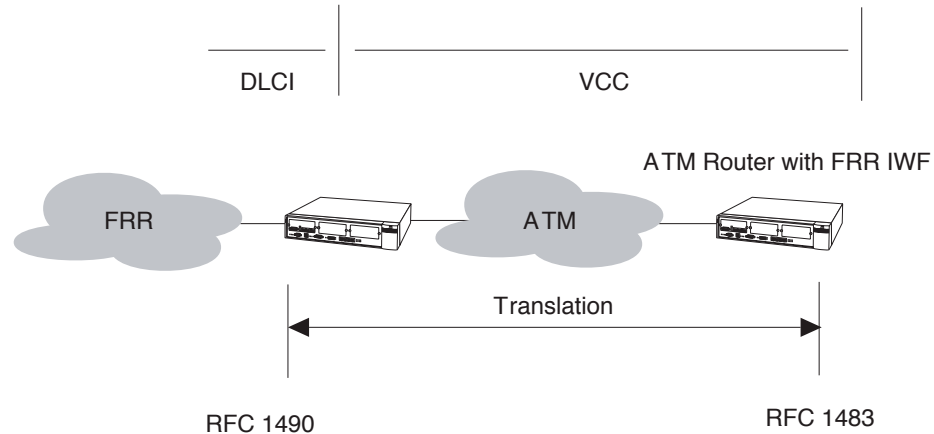

Figure 124 Translation Encapsulation Mode

DE-CLP / CLP-DE—DE to CLP / CLP to DE mapping. DE to CLP defines the value to which CLP will be set in outgoing ATM cells. CLP to DE mapping defines the value to which DE will be set from incoming ATM cells in outgoing Frame Relay frames.

Direct—Mode 1 mapping; matches DE value to CLP value. When the serial port is in this mode, it does not translate between Frame Relay (NLPID) encapsulation, rather it send it straight through the ATM network, possibly onto a Frame Relay network or device.

Always 0—Mode 2 mapping, with the CLP field mapped to a constant value of 0. Mode 2 is an operational method for indicating data congestion to either the ATM or Frame Relay network. Mode 2 allows for translation between NLPID and LLC-SNAP encapsulation. It is used when connecting a Frame Relay device or network to a non-Frame Relay device or network. For example, if the PathBuilder S330/S310 is connecting a router/FRAD over an ATM network (public or private) and at the other site a router with an ATM OC3/STM-1 UNI is connected to the WAN network, typically the router OC3/STM-1 UNI does not support NLPID and requires mode 2 mapping so that the packet can be encapsulated to LLC-SNAP.

Always 1—Mode 2 mapping, with the CLP field mapped to a constant value of 1. Mode 2 is an operational method for indicating data congestion to either the ATM or Frame Relay network. Mode 2 allows for translation between NLPID and LLC-SNAP encapsulation. It is used when connecting a Frame Relay device or network to a non-Frame Relay device or network. For example, if the PathBuilder S330/S310 is connecting a router/FRAD over an ATM network (public or private) and at the other site a router with an ATM OC3/STM-1 UNI is connected to the WAN network, typically the router OC3/STM-1 UNI does not support NLPID and requires mode 2 mapping so that the packet can be encapsulated to LLC-SNAP.

Start/End FR-SSCS DLCI—The starting and ending Frame Relay data link connection identifiers of the remote ATM Frame Relay host: 16...991.

FECN to EFCI Mapping—Defines the mapping of FECN incoming on Frame Relay to the outgoing ATM cell PTI congestion indicator.

Direct—Mode 1 mapping; matches FECN to the PTI CN bit. When the serial port is in this mode, it does not translate between Frame Relay (NLPID) encapsulation, rather it sends it straight through the ATM network, possibly onto a Frame Relay network or device.

Always 0—Mode 2 mapping. This option sets the EFCI field to 'congestion not experienced.' Mode 2 is an operational method for indicating data congestion to either the ATM or Frame Relay network. Mode 2 allows for translation between NLPID and LLC-SNAP encapsulation. It is used when connecting a Frame Relay device or network to a non-Frame Relay device or network. For example, if the PathBuilder S330 is connecting a router/FRAD over an ATM network (public or private) and at the other site a router with an ATM OC3/STM-1 UNI is connected to the WAN network, typically the router OC3/STM-1 UNI does not support NLPID and requires mode 2 mapping so that the packet can be encapsulated to LLC-SNAP.

DXI Virtual Circuit Parameters If the serial port is configured as a DXI port, you must set the following virtual circuit parameters in addition to the common *Shaper Number*, *Priority*, and *Early Packet Discard* parameters:

(DFA) VPI—The virtual path indicator (VPI) number corresponding to the DFA field: 0...15. This parameter defines the selected VPI for Mapping to/from the Port card (Router) to the trunk.

(DFA) VCI—The virtual channel indicator (VCI) number corresponding to the DFA field: 0...63. This parameter defines the selected VPI for Mapping to/from the Port card (Router) to the trunk.

(DFA) VCI Range—The DXI virtual channel indicator range: 1...32. This parameter defines the range of VCs starting from the one selected, in twos, and allows quick input of multiple VCs.

SDLC Virtual Circuit Parameters If the serial port is configured as a SDLC port, you simply set the common *Shaper Number*, *Priority*, and *Early Packet Discard* parameters.

Ethernet Port Virtual Circuit Parameters

For Ethernet port virtual circuits you simply set the common *Shaper Number*, *Priority*, and *Early Packet Discard* parameters.

CBR Module Virtual Circuit Parameters

The parameters that appear on the Add Virtual Circuit screen when you select the CBR module to be a side of a circuit vary, depending on whether you select the V.35 port or one of the T1/E1 ports. In addition to the common *Shaper Number*, *Priority*, and *Early Packet Discard* parameters, you must set the following parameters:

Port—The CBR module port number.

CDV Buffer Size—The Cell Delay Variation buffer size: *1-24 ms*. Cell delay variation refers to the spacing between cells. The PathBuilder S330/S310 provides a buffer to account for cell delay variation and thereby prevent cell loss. If the cell delay variation exceeds the size of the buffer, however, then you will lose cells. If your cell loss counts are high, try setting the cell delay variation to a higher value. Your service provider can tell you the maximum cell delay variation for your service.

Cell Loss Integ. Period—The amount of time the system will wait before declaring cell loss state.

Payload Size/Type—The ATM payload size and type. For ports other than structured voice DSX-1 ports, this is a read-only parameter. For structured voice DSX-1 ports, select *Voice* or *Data*.

- Set the *Payload Size/Type* to *Voice* to configure a CAS (channel associated signaling) channel for structured voice. For details, see "Configuring CBR Circuits for DBA," later in this Release Note.
- Set the *Payload Size/Type* to *Data* to configure a CBR circuit for clear channel signaling. For details, see "Configuring CBR Circuits for Clear Channel Signaling," later in this Release Note.

You can also set the *Payload Size/Type* to *Data* to configure CCS (common channel signaling), but this is not the preferred method. The recommended method for configuring CCS is to set the *CBR Port Mode* to *Structured Data*. For details, see "Setting up a PRI PBX Tie Line," later in this Release Note.

Onhook Detection—Enables or disables onhook detection. When you enable onhook detection, bandwidth is automatically reallocated based on the detection of an on-hook condition, as specified by the signaling type.

Signaling Type—The signaling application type: *No Signaling*, *E&M/PLAR*, *FXO-LoopStart*, *FXS-LoopStart*, or *FXO-GroundStart* for CBR T1-DSX; R2 for CBR E1. You can only modify this field in structured voice mode. In this mode, you can select any signaling application type except *No Signaling*. If you try to set the *Signaling Type* to *No Signaling* in structured voice mode, you will get an error. In structured/unstructured data modes, the *Signaling Type* defaults to *No Signaling* and cannot be modified.

V.35 Bandwidth—(serial port only) Speed (derived as $n \times 56/64K$).

Phone (RS366 templates only)—The destination phone number for the video-associated virtual circuit. You are prompted for this parameter only if you have set *Mode* to *Dial*. When you enter this number, the system runs a duplication check against the destination phone numbers that have already been entered. No calling plan is enforced, and the length of the destination phone numbers you enter for different virtual circuits can vary. When the destination phone number is dialed—either automatically through the RS-366 interface or manually through the terminal or SNMP interface—the virtual circuit is activated.

DS0 Channels—(T1-DSX/E1 ports only) Telco channels: the associated DS0s which have been assigned to the specified ATM VC connection. All available DS0 channels are automatically allocated in unstructured mode. In structured mode, the DS0 channels are bit-coded, with each bit representing one DS0 channel. You can assign DS0 channels in structured mode only. Channel conflicts within a T1/E1 port interface will result in an error.



If you are using CAS (channel associated signaling), you must build a virtual circuit for each DS0 you will use.

Voice Compression Module Virtual Circuit Parameters

If you are configuring a VCM VCC circuit, you simply set the common *Shaper Number*, *Priority*, and *Early Packet Discard* parameters. If you are configuring a VCM Subchannel circuit, you must also set the *DLCI*, *DS0 Channel*, and *Subchannel ID (SCID)*. For descriptions of the VCM Subchannel circuit parameters, see “Adding VCM Subchannel Circuits” earlier in this chapter.

VC and VP Address Translation

The PathBuilder S330/S310 supports VC and VP address translation on the receive VPI/VCI end of a circuit.

- To configure VP address translation, set the receive VCI to * when you enter the circuit address in the Add Virtual Circuit menu. This rule applies for all valid values of VPI (0 to 255).
- To configure VC address translation, set the VPI in the range 0 to 3, and set the VCI to a value other than x.

The PathBuilder S330/S310 software automatically sets the VCI to 0 whenever you select a VPI greater than 3 for the receive VPI, indicating that for values greater than 3 for the receive VPI, the PathBuilder S330/S310 can build only VP address-translated circuits. This is relevant only for the receive VPI/VCI end of the circuit.

Viewing Existing Virtual Circuits

You can view summaries of existing virtual circuits for the entire chassis or by port or group.

Viewing Virtual Circuits for the Entire Chassis

To view a summary of existing virtual circuits for the entire chassis, follow these steps:

- 1 From the Virtual Circuit menu, select *[1] List Virtual Circuits* to open the List Virtual Circuit Summary screen, shown in Figure 125.

The List Virtual Circuit summary screen, shown in Figure 125, appears. This screen shows a summary of all virtual circuits, with a virtual circuit number (VC#) assigned to each.

Figure 125 List Virtual Circuit Summary Screen

UC#	Side A card s/p rx tx	Side B card s/p rx tx	Description
1	SIM 5 DLCI:16	DS1 3/1 0/6 0/6	testcircuit5
2	CBRE 7/1 Tel:1	DS1 3/1 0/3 0/3	testcircuit3
3	CBRE 7/4 24 x 64k	DS1 3/1 0/2 0/2	testcircuit2
4	UCMD 8	DS1 3/1 0/1 0/1	testcircuit1
5	UCMD 8 DS0:1 SCID:4	DS1 3/1 0/1 0/1	testcircuit7

Enter item# (1..5),
ESC for previous menu: █

The List Virtual Circuit Summary Screen shows a summary of all virtual circuits, with a virtual circuit number (VC#) assigned to each. It displays the following information:

card—Card type.

s/p—Slot and port numbers (for side A and side B of the circuit)

Rx/Tx—Virtual circuit information specific to the card type. For example, for UNI cards, these columns list the receive/transmit VPI/VCI (for side A and side B of the circuit), while for CBR cards these columns list the DS0 channels.

Description—The description entered when the circuit was configured.

- To view more detailed information about a specific virtual circuit enter the VC# of the circuit you want to view from the List Virtual Circuit Summary screen to open the List Virtual Circuit Detail screen. This screen displays the complete list of parameters for both sides of the selected circuit.

Figure 126 shows a representative List Virtual Circuit detail screen.

Figure 126 List Virtual Circuit Detail Screen

```

Telnet - 209.31.3.23
Connect Edit Terminal Help
testnode PathBuilder S330 Alarm Read-Write
List Virtual Circuits

Circuit Type: Unicast,UCC          Description: testcircuit5
Admin. Status: 2(in service)
SIDE A                               SIDE B
Slot/Port/Card: 5/SIM              Slot/Group/Card: 3/1/DS1 UNI (4)
Interworking Mode: Network          Receive UPI/UCI: 0/6
Start/End Frame Relay DLCI: 16/16  Transmit UPI/UCI: 0/6
Encapsulation Mode: N/A             Priority: 3
DE-CLP/CLP-DE: 1(Direct)/2(Direct) Early Packet Discard: 1(no)
Start/End FR-SSCS DLCI: 16/16
FECN to EFCI Mapping: N/A
Shaper Number: 1(56K/784K)
Priority: 1
Early Packet Discard: 1(no)

Press any key to continue.

```

Viewing Virtual Circuits by Port or Group

To view a summary of existing virtual circuits for a selected port or group, follow these steps:

- 1 From the Configuration Management menu, select [2] *Manage Circuit* to open the Virtual Circuit menu, shown earlier in Figure 103
- 2 From the Virtual Circuit menu, select [6] *Access Virtual Circuits by Port/Group* to open the Access VCs by Port/Group Selection menu, shown in Figure 127. This menu lists the ports and groups on the chassis for which virtual circuits have been defined and the number of VC sides associated with each port/group.

Figure 127 Access VCs by Port/Group Selection Menu

```

Telnet - 209.31.3.23
Connect Edit Terminal Help
testnode PathBuilder S330 Alarm Read-Write
Access VCs By Port/Group

Port/Group          # UC sides
-----
1) DS1 3/1          3
2) CBRE 7/1         1
3) CBRE 7/4         1
4) UCMD 8           1

Enter item# (1..4) to display port/group VCs,
ESC for previous menu:

```

- 3 Enter the number corresponding to the port or group for which you want to view virtual circuits to open the Access Virtual Circuits by Port/Group screen, shown in Figure 128.

Figure 128 Access Virtual Circuits by Port/Group Screen

UC#	Side A				Side B				Description
	card	s/p	rx	tx	card	s/p	rx	tx	
1	UCMD	8			DS1	*3/1	0/1	0/1	testcircuit1
2	CBRE	7/4	24 x 64k		DS1	*3/1	0/2	0/2	testcircuit2
3	CBRE	7/1	Tel:1		DS1	*3/1	0/3	0/3	testcircuit3

Enter item# (1..3),
ESC for previous menu: █

The Access Virtual Circuits by Port/Group screen provides the same information as the List Virtual Circuit screen. See “Viewing Virtual Circuits for the Entire Chassis” earlier in this section for details.

To view detailed information about one of the listed circuits, enter the desired VC# to open the Access Virtual Circuits by Port/Group detail screen. This screen provides the same information as the List Virtual Circuits Detail screen, shown earlier in Figure 126. See “Viewing Virtual Circuits for the Entire Chassis” earlier in this section for details.

From the Access Virtual Circuits by Port/Group detail screen, you can:

- Enter **s** to view statistics for the selected circuit.
- Enter **d** to delete the circuit.
- Enter **m** to modify the circuit.

Modifying Existing Virtual Circuits

To modify an existing virtual circuit, follow these steps:

- 1 From the Virtual Circuit menu, select **[3] Modify Virtual Circuit**. The Modify Virtual Circuit selection screen appears. This screen displays a list of existing virtual circuits.
- 2 Enter the VC# of the circuit you want to modify.

The following prompt appears:

```
Enter Description (12 characters maximum): <circuit description>
```

where <circuit description> is the *Description* for the selected circuit.

- 3 If desired, change the circuit description by backspacing and typing over the existing description; otherwise, press [Return] to change other circuit parameters.
- 4 Follow the prompts that appear at the bottom of the screen to modify the circuit parameters as desired.

Deleting Virtual Circuits To delete an existing virtual circuit, follow these steps:

- 1 From the Virtual Circuit menu, select [4] *Delete Virtual Circuit*. The Delete Virtual Circuit screen appears. This screen displays a list of existing virtual circuits.
- 2 Enter the VC# of the circuit you want to delete.

The following prompt appears:

Are you sure you want to delete VC# <VC number>

where <vc number> is the number of the selected virtual circuit.

- 3 Enter **y** in response to the confirmation prompt to delete the circuit.



When you delete a virtual circuit involving the CBR module in structured voice mode, the DSO channels associated with that circuit are trunk conditioned and can no longer be used. See “DSO Trunk Conditioning” earlier in this chapter for further details about trunk conditioning.

Managing the Video Dial Feature

This section tells you how to manage video dial-up sessions and view the call routing table.



Before you can establish video dial-up sessions, you must configure video virtual circuits. For details see “Defining RS366 (Video) Virtual Circuit Templates” earlier in this chapter.

You manage the video dial feature from the Manage Video Dial menu, shown in Figure 129.

To display the Manage Video Dial menu:

From the Configuration Management menu, select [4] *Manage Video Dial*.

Figure 129 Manage Video Dial Menu

```

Telnet - 198.93.64.100
Connect Edit Terminal Help
testnode PathBuilder S330 Alarm Read-Write
          Manage Video Dial Menu

          1. Display Video Call Routing Table
          2. Manually Connect (Dial) A Site
          3. Manually Disconnect A Site
          4. Previous Menu

          Please enter a selection 1 to 4 [4]: █
  
```

Managing Video Dial-up Sessions

To set up, activate, and end a video dial-up session, follow these basic steps:

- 1 Create virtual circuits between the appropriate PathBuilder S330/S310 units. This effectively builds a call routing table.
For detailed instructions, see “Defining RS366 (Video) Virtual Circuit Templates”, earlier in this chapter.
- 2 Start the session either manually or automatically via the RS-366 interface. For details, see “Starting Video Dial-up Sessions” later in this section.
- 3 End the session either manually or automatically via the V.35 interface. For details, see “Ending Video Dial-up Sessions” later in this section.

Starting Video Dial-up Sessions

A video dial-up session starts (connects) automatically when someone dials a number matching one of the numbers in the call routing table (one of the numbers associated with an RS366 virtual circuit template) on a video keypad. You create the call routing table by building virtual circuits between PathBuilder S330/310 CBR modules. For details about building video virtual circuits, see “Defining RS366 (Video) Virtual Circuit Templates”, earlier in this chapter. For details about viewing the call routing table, see “Viewing the Video Call Routing Table” later in this section.

You can also start (connect) a video dial-up session manually. To do this, follow these steps:

- 1 From the Configuration Management menu, select [4] *Manage Video Dial* to display the Manage Video Dial menu, shown earlier in Figure 129.
- 2 From the Manage Video Dial menu, select [2] *Manually Connect (Dial) A Site* to display the Manually Connect A Site menu, shown in Figure 130. The current connection status is displayed at the top of the menu.

Figure 130 Manually Connect A Site Menu

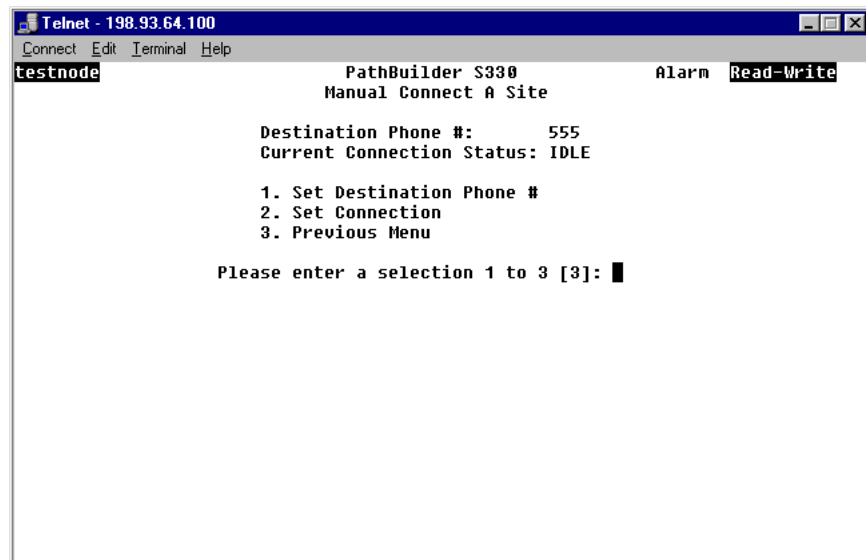

- 3 Select *[1] Set Destination Phone #* and enter the phone number of the site to which you want to connect.
- 4 Select *[2] Set Connection*. The session begins as soon as the software matches the phone number you entered in step 3 to one of the numbers on the call routing table (one of the numbers associated with an RS366 virtual circuit template).

Ending Video Dial-up Sessions

A video dial-up session ends (disconnects) automatically when the video call is disconnected.

You can also end (disconnect) a video dial-up session via the PathBuilder S330/S310 interface. To do this, follow these steps:

- 1 From the Configuration Management menu, select *[4] Manage Video Dial* to display the Manage Video Dial menu, shown earlier in Figure 129.
- 2 From the Manage Video Dial menu, select *[3] Manually Disconnect A Site* to display the Manually Disconnect A Site menu, shown in Figure 131. The destination phone number for the current session and the current connection status are displayed at the top of the menu.

Figure 131 Manually Disconnect A Site Menu

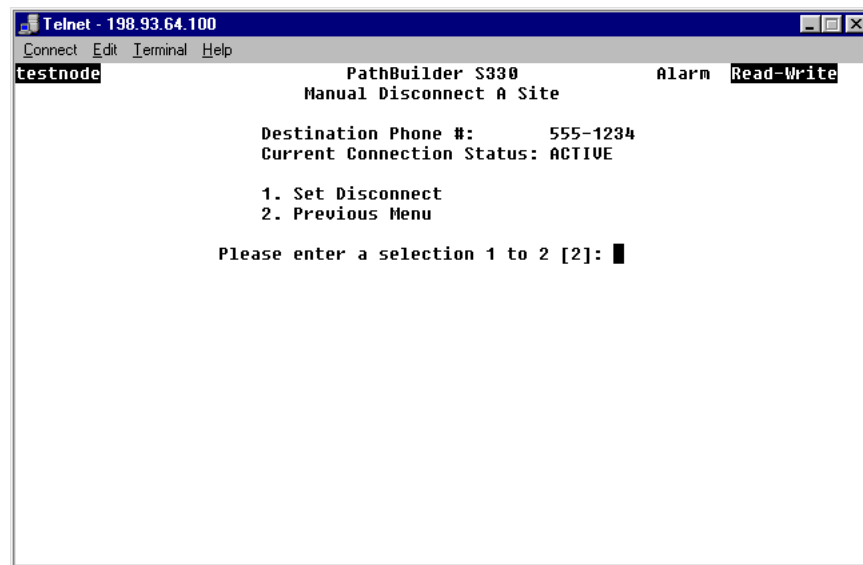

Check that a destination phone number and a current connection status of active are listed at the top of the Manually Disconnect A Site menu. If there is no active connection, your disconnect request will be rejected by the system.

- 3 Select *[1] Set Disconnect* to end the dial-up session.

Viewing the Video Call Routing Table

You build the video call routing table as you create video-associated virtual circuits between PathBuilder S330/S310 CBR modules. When you enter a number—either from a video keypad or from the Manually Connect A Site menu—to start a video dial-up session, the system checks the number you enter against the call routing table and makes a connection if it finds a match.

To view the video call routing table, follow these steps:

- 1 From the Configuration Management menu, select [4] *Manage Video Dial* to display the Manage Video Dial menu, shown earlier in Figure 129.
- 2 From the Manage Video Dial menu, select [1] *Display Video Call Routing Table* to display the Video Call Routing Table, shown in Figure 132.

Each row in the video call routing table corresponds to a video-associated virtual circuit (call) between PathBuilder S330/S310 CBR modules. The table provides the following information for each entry:

Index—A unique number identifying this entry in the call routing table.

Dest Phone #—The destination phone number associated with this call.

Tx VPI/VCI—The trunk transmission VPI/VCI associated with this call.

Rx VPI/VCI—The trunk receiving VPI/VCI associated with this call.

Speed—The speed of the call, in kbps.

Status—The status of the call: *idle* or *active*.

Figure 132 Video Call Routing Table

```

Telnet - 209.31.3.23
Connect Edit Terminal Help
testnode PathBuilder S330 Alarm Read-Write
          Display Video Call Routing Table
-----
Index  Dest Phone #          Tx VPI/VCI  Rx VPI/VCI  Speed      Status
-----
1       535-2345                0/2         0/2         24 x 64K   Idle
2       535-2347                0/3         0/3         1 x 64K    Idle
-----

ESC for previous menu: █

```

5

PATHBUILDER S330 DIAGNOSTICS AND PERFORMANCE STATISTICS

This chapter tells you how to access and manage SuperStack II PathBuilder S330 and S310 WAN access switch (PathBuilder S330/S310) system alarms, how to use available loopbacks, and how to view performance statistics for the PathBuilder S330/S310. It contains the following sections:

- Managing System Alarms
- Using Loopbacks
- Viewing Performance and ATM Statistics
- Viewing Virtual Circuit Statistics

Managing System Alarms

The PathBuilder S330 detects certain events and reports corresponding alarms and traps to the NMS station(s). These events are categorized as major alarms, minor alarms, and information. When an alarm occurs, an alarm indicator is displayed on the current menu or display, as described under “Alarm Indicator” in Chapter 3.

Viewing and Clearing Current Alarms

To view a list of current alarms, follow these steps:

- 1 From the Main menu, select [3] *Fault Management* to display the Fault Management menu shown in Figure 133.

Figure 133 Fault Management Menu

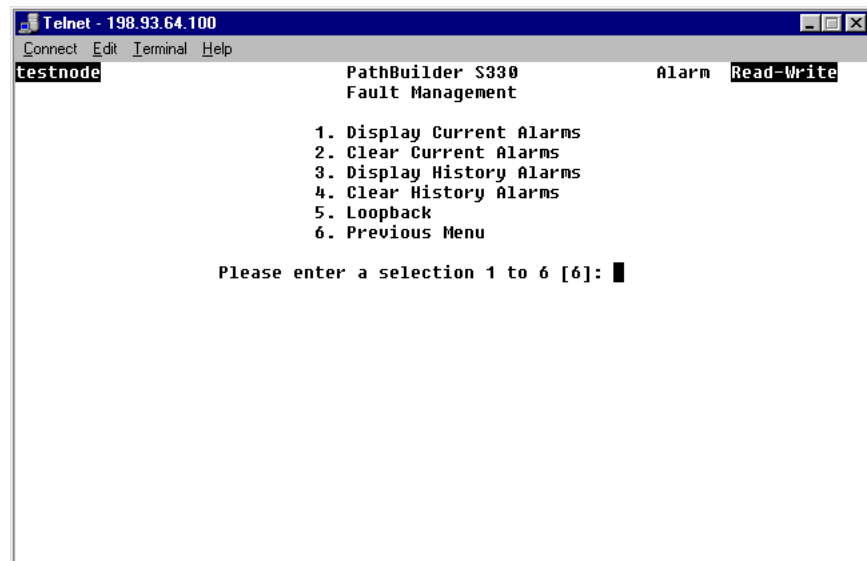

```
Telnet - 198.93.64.100
Connect Edit Terminal Help
testnode PathBuilder S330 Alarm Read-Write
          Fault Management

          1. Display Current Alarms
          2. Clear Current Alarms
          3. Display History Alarms
          4. Clear History Alarms
          5. Loopback
          6. Previous Menu

          Please enter a selection 1 to 6 [6]: █
```

- 2 Select *[1] Display Current Alarms* to view a list of current alarms, as shown in Figure 134.

Figure 134 Sample Current Alarm Display

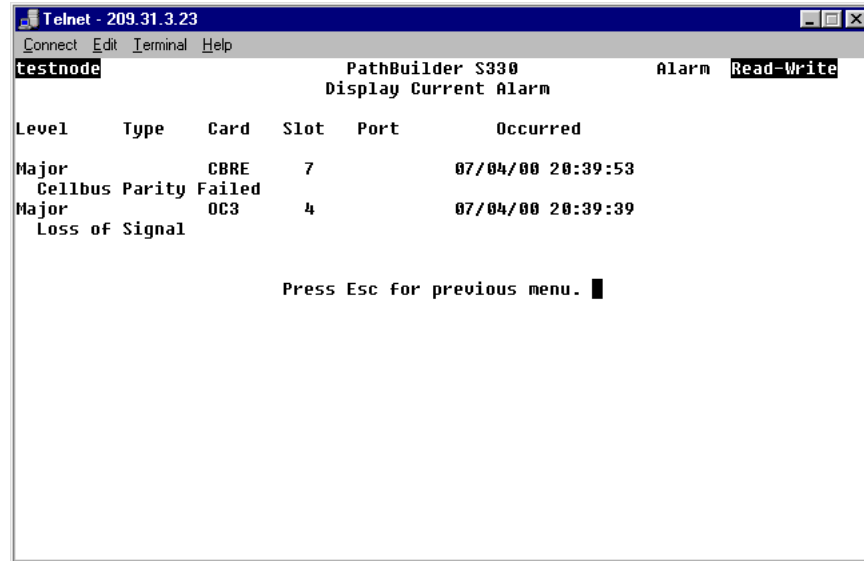

To determine whether or not an alarm-generating condition has been resolved, clear the current alarms and recheck the Display Current Alarms screen, as follows:

- 1 From the Display Current Alarm screen, press [Esc] to return to the Fault Management menu.
- 2 Select *[2] Clear Current Alarms*.
- 3 Enter **y** in response to the confirmation prompt to clear the current alarms.
- 4 Select *[1] Display Current Alarms* to return to the Display Current Alarms screen.
 - Alarm-generating conditions that are still present will regenerate alarms on the Display Current Alarms screen.
 - Alarm-generating conditions that are no longer present will no longer generate alarms on the Current Alarm screen.

PathBuilder S330/S310 Alarm Messages

This section lists the alarm messages, meanings of the alarm messages, and troubleshooting tips for the major errors reported from each of the PathBuilder S330/S310 interfaces. It contains the following subsections:

- MCPU and CTX Module (System) Alarms
- Alarms Common to Several Interfaces
- DS1/E1 UNI Module Alarms
- DSX-1/E1 CBR Module Alarms
- SIM Alarms
- Voice Compression Module Alarms

MCPU and CTX Module (System) Alarms

Table 26 describes the Critical and Major Alarms associated with the CPU Module.

Table 26 MCPU and CTX Module (System) Alarms

Alarm	Meaning	Troubleshooting Steps
Alarms Cleared	Current alarms have been cleared by user.	Information only.
Card Config Failed	Cannot upload configuration data to a card.	Information only. Could indicate a potential problem. You may need to reset the card.
Card initialized.	Card initialized.	Information only.
Card Reconfig Failed	Reconfiguration of the card failed	Information only. Could indicate a potential problem. You may need to reset the card.
Card Reconfigured	Card is reconfigured.	Information only. Could occur when the card is plugged in or the system is powered up.
Communication Failed	Error during communication between MCPU and a slot.	Replace the unit.
DS3/E3/OC3/CBR/IMA/VCM Ref Clk Failed	Interface clock has been designated as the system clock, and the interface clock has failed.	Check the physical connection. Check for other alarms such as LOS/LOF/LOCD. Check the physical connection.
Fan #1 failed	Fan #1 failed	Replace the fan tray.
Fan #2 failed	Fan #2 failed	Replace the fan tray.
History Overflowed	Alarm history table has overflowed. Alarms will continue to be recorded but will displace oldest alarms.	Clear the history alarms table through NMS or Telnet.
Id Prom Checksum Error	The internal checksum on the idprom of the indicated card is incorrect.	Have the idprom replaced with the correct version. The system takes no action if it recognizes the proper card ID.
Invalid DB Cardtype	An unknown card type is found in the database	Information only.
Login Failure	Failed log -in. Someone failed to log in to the shelf three successive times.	Information only.
Loss 8KHz Ref Clock	The system reference clock was lost.	Try reassigning the clock—especially to <i>internal</i> .
New Card Configured	Configuration data for a new card is uploaded.	Information only. The card was not stored in the database.
PWR Supply Failed	Power supply has failed.	Replace the power supply with an operating unit.
Queue 0 Over Threshold	The congestion threshold for Queue 0 was exceeded.	Check and correct VC connections. Check and adjust VI shaper values. Check and adjust incoming traffic volume. Check for faulty IMA links which may reduce traffic handling for a group.

(continued)

Table 26 MCPU and CTX Module (System) Alarms (continued)

Alarm	Meaning	Troubleshooting Steps
Queue 1 Over Threshold	The congestion threshold for Queue 1 was exceeded.	Check and correct VC connections. Check and adjust VI shaper values. Check and adjust incoming traffic volume. Check for faulty IMA links which may reduce traffic handling for a group.
Queue 2 Over Threshold	The congestion threshold for Queue 2 was exceeded.	Check and correct VC connections. Check and adjust VI shaper values. Check and adjust incoming traffic volume. Check for faulty IMA links which may reduce traffic handling for a group.
Queue 3 Over Threshold	The congestion threshold for Queue 3 was exceeded.	Check and correct VC connections. Check and adjust VI shaper values. Check and adjust incoming traffic volume. Check for faulty IMA links which may reduce traffic handling for a group.
SAR Initialize Failure	Problem with the SAR chip on the MCPU. MCPU SAR failed initialization.	Replace the unit.
System Clock Reverted	The system clock has reverted to a higher priority clock.	Information only. This alarm occurs only if the <i>Clock Mode</i> is set to <i>Revertive</i> on the System Clock Configuration menu.
System power up	System is powered up.	Information only.
Write Session Taken by Super User	A super user has changed a read-only session to read-write.	Information only.

Alarms Common to Several Interfaces

Table 27 describes major alarms common to several PathBuilder S330/S310 interfaces.

Table 27 Alarms Common to Several Modules

Alarm	Meaning	Troubleshooting Steps
Alarm Indication Signal(AIS)	An incoming alarm indication signal (AIS) indicates a LOS problem is occurring on the line upstream of the equipment connected to this port.	Check your locally connected DS3/E3/OC3 equipment, or ask your service provider to trace the source of the AIS signal.
Far End Receive Failure	The far end equipment has a problem with the signal it is receiving from the PathBuilder device.	Check for a defective cable between the PathBuilder device network interface port and your service provider's network interface unit. An open transmit line can cause this condition. Check the LBO setting of the port.
FEAC Loopback	A DS3 overhead function that allows the system to be enabled or disabled for responding to Far End Alarm Condition commands from the central office. When enabled, the DS3 line loopback is put up upon instruction from the central office. The system removes the loopback upon instruction or after 15 minutes.	Check with your service provider to determine the reason for the loopback.
Idle Signal	The line has not been provisioned for service. No data will pass on a line with an idle signal.	Check the configuration of the terminal equipment, or have your service provider check their equipment and make sure it is provisioned for service.
In Band Loopback	A loopback is configured on the port. Loopbacks are for troubleshooting only and should not be present under normal operating conditions.	If you are not troubleshooting the port, turn off the loopback.
Link Down	Summary informational alarm to indicate one or more alarms on this link are active.	Information only.
Link Up	Summary informational alarm to indicate all alarms on the physical link are cleared.	Information only.
Local Card Loopback	A loopback is configured on the port. Loopbacks are for troubleshooting only and should not be present under normal operating conditions.	If you are not troubleshooting the port, turn off the loopback.
Loss of Cell Delineation(LOCD)	Loss of cell delineation—possibly a framing or timing problem.	Check the reference clock source. Compare parameters between local and service provider end. Check the physical layer.

(continued)

Table 27 Alarms Common to Several Modules (continued)

Alarm	Meaning	Troubleshooting Steps
Loss of Signal(LOS)	Cannot detect a signal at a configured port. This alarm is applicable to DS3 UNI, E3 UNI, OC3/STM-1 UNI, DS1 IMA UNI, and E1 IMA UNI ports.	Check the cable between the interface port and the service provider's equipment/terminal equipment. Check cable connections. Check transmit and receive pairs for proper connection. Check terminating equipment. Call your service provider.
Network Card Loopback	A loopback is configured on the port. Loopbacks are for troubleshooting only and should not be present under normal operating conditions.	If you are not troubleshooting the port, turn off the loopback.
Network Line Loopback	A loopback is configured on the port. Loopbacks are for troubleshooting only and should not be present under normal operating conditions.	If you are not troubleshooting the port, turn off the loopback.
Out of Frame(OOF)	The configuration settings on the port are not correct for the line, or the port configuration is correct, but the line is experiencing errors that result in an alarm.	Verify that the framing format configured on the port matches the framing format on the line. Check the port's statistics report for evidence of a bad line; bursts of LCVs could indicate a timing problem. If connected to local DS3/E3/OC3 equipment, check that equipment's output level to make sure it is not overdriving the input.

DS1/E1 UNI Module Alarms

Table 28 describes the alarms specific to the DS1 UNI and E1 UNI modules.



ATM Forum required alarms are indicated by the notation ATM Forum (R-xxx), where xxx is the required alarm number.

Table 28 DS1/E1 UNI Module Alarms

Alarm	Meaning	Troubleshooting Steps
AFA Link Removal	Automatic Frequency Adjustment - Link removed from physical line group due to error rate in CRC check of T1/E1 exceeding user specified rate for a given period of time.	Check the removed link for the CRC errors.
Bad IMA ID	A link within the group has received an IMA ID from the far end that is different than when the group was initialized (and from the other links in the group). The link with the bad IMA ID is probably misconnected.	Check the links for proper connection. Reconnect if necessary.
Bad Link ID	Each IMA group assigns a unique Transmit link ID to each link in the group. This link ID should match the Receive link ID of the remote end IMA device. This alarm means that a link was operating correctly, but then received a Transmit link ID already assigned to a previous link. A Tx Misconnected alarm is also generated.	Check the links for proper connection. Reconnect if necessary.
Bad M	The far end frame size M has changed in an IMA link. The maximum value for the frame size on the local device's serial card must match the maximum value for the frame size of the connected device. The link with the BAD M is probably misconnected.	Check to make sure the maximum frame size is set to the same value on the local and remote ends.
Bad Offset	Far end ICP cell offset has changed in an IMA link. Each IMA group assigns a unique Transmit offset to each link in the group. This alarm means that a link was operating correctly, but then received a Transmit offset already assigned to a previous link. A Tx Misconnected alarm is also generated.	Check the links for proper connection. Reconnect if necessary.

(continued)

Table 28 DS1/E1 UNI Module Alarms (continued)

Alarm	Meaning	Troubleshooting Steps
BAD SCCI (3Com Patent Pending)	Status and Change Control Indication – the content of the ICP cells has changed. The far end ICP cell SCCI in this link does not agree with the SCCI of the other links in the group.	Check the links for proper connection. Reconnect if necessary.
Bad Symmetry	The far end group symmetry has changed in an IMA link.	Remove the link and stop Tx and Rx data.
Duplicated IMA ID	An IMA group has received an IMA ID that has been received by a previous group. The second group must have a unique IMA ID.	Check for loops and check the IMA group configuration.
Duplicated Link ID	Duplicated far end logical link ID in this IMA group for this IMA link. Each IMA group assigns a unique Transmit link ID to each link in the group. This link ID should match the Receive link ID of the remote end IMA device. This alarm means that a link received a Transmit link ID already assigned to a previous link.	Check the links for proper connection. Reconnect if necessary.
Duplicated Offset	Duplicated far end ICP cell offset in this IMA group in an IMA link. Each IMA group assigns a unique Transmit offset to each link in the group. This alarm means that a link received a Transmit offset already assigned to a previous link. Some of the links are probably misconnected.	Check the links for proper connection. Reconnect if necessary.
Excessive Link Delay	The link has exceeded the user-selectable value for acceptable link delay. The link is removed from the group.	Check the links for proper connection. Reconnect if necessary. Also try adjusting the link delay parameter for the IMA group.
Group [n] Abort Symmetry	Generated when <i>Group [n] Config. Abort</i> is generated, due to group symmetry problem	Check and correct near end symmetry. Only symmetric operation is supported in PathBuilder products.
Group [n] Config Abort	The near end node rejects the far end IMA parameters.	Check and correct the near end and far end parameters for compatibility.
<i>ATM Forum (R-128)</i>		
Group [n] Degraded Service	The IMA group is passing data with less than the number of IMA links you configured.	Continue passing data. Correct faulty links or adjust IMA group configuration.

(continued)

Table 28 DS1/E1 UNI Module Alarms (continued)

Alarm	Meaning	Troubleshooting Steps
Group [n] Dup. IMA ID	The same group IMA ID has been received on links belonging to different IMA groups in the same card.	Correct link or group configuration.
Group [n] FE Abort Symmetry	The far end rejects the symmetry sent by the near end.	Check and correct near end symmetry. Only symmetric operation is supported in PathBuilder products.
Group [n] FE Blocked <i>ATM Forum (R-132)</i>	The far end reports it is not passing data.	Check and repair link facilities. Verify configuration.
Group [n] FE Config Abort	The far end rejects the M value used by the near end.	Configure both ends to the same M value. NOTE: This alarm should not occur if both ends are PathBuilder S310, S330, S600, or S700 products.
Group [n] FE Start Up <i>ATM Forum (R-127)</i>	The far end is coming up (starting IMA).	Information about far end state.
Group [n] FE Insufficient Links <i>ATM Forum (R-131)</i>	The far end node is reporting an insufficient number of links.	Check and repair link facilities. Verify configuration.
Group [n] Insufficient Links <i>ATM Forum (R-130)</i>	The near end finds not enough available links. This occurs when the near end has completed parameter negotiation with the far end, but is neither passing data nor blocked.	Check and correct any faulty IMA links. Check and correct IMA minimum links parameter.
Group [n] Lack of Link	The near end is idling because it does not have enough links in an IMA group. This occurs only after group parameters are negotiated. When this occurs, the "NE Insufficient Links" alarm is also reported.	Take the group down, and stop passing data in all links.
Group [n] Link Down	Summary information alarm to indicate one or more alarms on this IMA group are active.	Information only.
Group [n] Link Up	Summary informational alarm to indicate all alarms on the IMA group are cleared.	Information only.
Group [n] N<P	There are fewer configured links than IMA links required to make an IMA group active.	Continue passing data.
Group [n] No Link	The near end has lost all its links in an IMA group because these links have AFA, LOS, AIS, OOF, LCD, or missing ICP cells. This invalidates all the far end identity.	If one or more links comes back, re-identify the link(s) and renegotiate parameters with the far end group.

(continued)

Table 28 DS1/E1 UNI Module Alarms (continued)

Alarm	Meaning	Troubleshooting Steps
Group [n] Multi IMA ID	Different group IMA ID received on different links in an IMA group.	Correct link connections and/or IMA group configuration.
Group [n] Multi Test <i>ATM Forum (R-138)</i>	Different test procedure request from different links in an IMA group from the far end.	Use the test procedure from the lowest logical link and ignore the other test procedures.
Group [n] Multiple M	Different frame lengths received on different links in an IMA group.	Make sure that the IMA frame length is set to the same value for all links.
Group [n] Multiple Symmetry	Different group symmetry received on different links in an IMA group (symmetrical versus asymmetrical operation).	Configure the group to be symmetric. 3Com PathBuilder products do not support asymmetric bandwidth for IMA.
Group [n] Time Sync Fail	The far end transmit clocking mode does not match the near end transmit clocking mode	Check configuration. Only CTC (Common Transfer Clock) is supported. If the far end transport clocking is set to ITC (Independent Transfer Clock), change it to CTC.
IMA Protocol Mismatch	IMA label is not ATM Forum 1.0.	Near end and far end IMA protocol versions do not match. Check and correct incompatibility.
IMA Remote Loopback	Far end loopback detected, external cable loopback or crosstalk.	Remove loopback condition.
IMA Tx Misconnected <i>ATM Forum (R-123)</i>	The near end IMA networking Tx or Rx link state machine detects the link is not connected to the correct FE Tx or Rx links.	Remove the link and stop Tx and Rx data.
Loss of Differential Synchronization (LODS) <i>ATM Forum (R-122)</i>	Relative time difference between individual T1s/E1s in the IMA group is out of range. LODS is declared after the Rx IMA fails to synchronize the IMA link(s) in an IMA group within some time limit.	Have your carrier verify the time sync and routing of individual T1s/E1s in the group. Check the IMA group configuration to ensure consistency on the local and remote ends.
Loss of IMA Frame (LIF) <i>ATM Forum (R-121)</i>	Loss of IMA Frame is detected in the Rx direction for an IMA link UP. There is an IMA frame size mismatch between two ends of the circuit. This can be caused by missing ICP cells (ATM cells that carry protocol information), bad IMA ID, bad sequence number, bad M, bad offset HEC error or CRC error in ICP cells. This problem may occur if the link gets noisy and there is no AFA to prevent the ICP from getting corrupted. It is detected in hardware and may or may not cause an operational problem.	Check the IMA group configuration to ensure consistent frame size on the local and remote ends. Check links for evidence of noise. Check to be sure that AFA is enabled.

(continued)

Table 28 DS1/E1 UNI Module Alarms (continued)

Alarm	Meaning	Troubleshooting Steps
Port Missing ICP Cells	Two consecutive ICP cells missing from the IMA frame.	See also <i>Loss of IMA Frame (LIF)</i> . This is a specific cause of that alarm and will also be reported.
RFI IMA <i>ATM Forum (R-121)</i>	Remote Failure Indication: Far end IMA Rx networking link state machines detected LOS, OOF, AIS, LCD, LIF or LODS.	Correct T1 or E1 facilities error.
Test Pattern Failed	An 8-bit pattern is sent to the remote node which must then echo it back on all ports. The local node checks the echoed pattern and reports an alarm if cells from one or more of the links fail to arrive. This alarm is declared on all links which do not reply or reply incorrectly.	Make sure that the same number of links are configured and enabled on both ends of the IMA configuration. Make sure that the configuration of both groups is the same. For instance, make sure that the payload scrambling setting is the same on both ends.
Yellow Alarm	OOF alarm is detected. A received remote alarm indication means that the far end equipment has a problem with the signal it is receiving from the PathBuilder device.	Connect an external loopback cable to the port. If there are no alarms, the problem is elsewhere. Check for an open, short, or wiring error in the cable between the PathBuilder network interface port and your service provider's network interface unit, or the terminal equipment. An open transmit pair can cause this condition

DSX-1/E1 CBR Module Alarms

Table 29 describes the alarms specific to DSX-1 and E1 CBR modules.

Table 29 DSX-1/E1 CBR Module Alarms

Alarm	Meaning	Troubleshooting Steps
Cellbus parity	Parity error on cells received from cell bus.	Check VC and port configuration.
E1 Loss of CAS Multiframe	E1 signaling multiframe alignment has been lost.	Check the physical connection and the carrier for configuration problems.
E1 Time Channel 16 AIS Rcv	All 1s in E1 time slot 16 for 2 consecutive frames.	Make sure both the local device and the far end device are configured for Time Slot 16 framing. If both devices are correctly configured, there may be a hardware problem in either device.
Far End E1 Loss of CAS	The far end device has lost Channel Associated signaling.	Check the E1 configuration of the far end device.
HP cellbus congested	High priority cell bus congested. The cell port has been configured to pass more CBR traffic than it can physically handle. The aggregate bandwidth of the CBR connections exceeds the total bandwidth of the port. This alarm indicates that you either mistakenly oversubscribed the cell port with CBR connections, or more connections than expected are simultaneously active. When this condition exists on the HP cell bus, lower priority cell busses will not be able to pass traffic out.	Remove high priority connections until the configured bandwidth is less than or equal to the total bandwidth on the port. If you have over-subscribed the port and all high priority devices are using the connections, turn off some devices.
LP cellbus congested	Low priority cell bus congested.	Remove low priority connections until the configured bandwidth is less than or equal to the total bandwidth on the port. If you have over-subscribed the port and all low priority devices are using the connections, turn off some devices.
MP cellbus congested	Medium priority cell bus congested.	Remove medium priority connections until the configured bandwidth is less than or equal to the total bandwidth on the port. If you have over-subscribed the port and all medium priority devices are using the connections, turn off some devices.
Receive FIFO Overflow	Cells are being received from the cell bus faster than the CBR can process them.	Reconfigure the CBR connection so that it has adequate bandwidth.
SAR SRAM failure	SAR SRAM failure (applicable to CBR)	Replace the unit.

(continued)

Table 29 DSX-1/E1 CBR Module Alarms (continued)

Transmit FIFO Overflow	The cell bus is congested, and cells are backed up on the CBR. Traffic at the output side of the CBR port is being transmitted more slowly than it is being received from the cell bus. As a result, the output buffer is overflowing. In general, the problem is that the CBR connection is not synchronized end-to-end. The clock rate of the output port does not match the clock rate of the device from which the traffic originated.	The entire CBR connection must be synchronous end-to-end. Make sure the clock rates of the devices at either end of the connection match each other and match the transmit clock rate of the CBR ports on the PathBuilder device.
VC RDI Receive	VC RDI (Remote Defect Indication) OAM received in the connection. The far end equipment has a problem with the signal it is receiving, indicating that the problem lies between the network provider and the far end terminal equipment for this connection.	Check for a defective cable between the far end interface port and your service provider's network interface unit. An open transmit line can cause this condition.

SIM Alarms

Table 30 describes the alarms specific to QSIMs and FAMs

Table 30 QSIM Alarms

Alarm	Meaning	Troubleshooting Steps
LMI Link Down	The Local Management Interface has taken the link down.	Check the LMI protocol configuration for the port.

Voice Compression Module Alarms

Table 29 describes the major alarms specific to the Voice Compression module.

Table 31 Voice Compression Module Alarms

Alarm	Meaning	Troubleshooting Steps
E1 Loss of CAS Multiframe	E1 signaling multiframe alignment has been lost.	Check the physical connection and the carrier for configuration problems.
E1 Time Channel 16 AIS Rcv	All 1s in E1 time slot 16 for 2 consecutive frames.	Make sure both the local device and the far end device are configured for Time Slot 16 framing. If both devices are correctly configured, there may be a hardware problem in either device.
Far End E1 Loss of CAS	The far end device has lost Channel Associated signaling.	Check the E1 configuration of the far end device.
Channel PCM Loopback Condition	A loopback is configured on the channel. Loopbacks are for troubleshooting only and should not be present during normal operating conditions.	If you are not troubleshooting the channel, turn off the loopback.

Working with History Alarms

All alarms and information events are captured and kept in an alarm history file in the PathBuilder S330/S310. This file can hold up to 300 events; it fills on a first-in/first-out basis. We recommend that you routinely view the alarm history file before events are lost. We also recommend that you print the file for comparison with previous history files and entry into your maintenance log.

Viewing and Printing History Alarms

To view and print an alarm history, follow these steps:

- 1 From the Main menu, select *[3] Fault Management* to display the Fault Management menu shown in Figure 133.
- 2 Select *[3] Display History Alarms* to view the alarm history. Figure 135 shows a sample alarm history.

Figure 135 Sample Alarm History Display

Level	Type	Card	Slot	Port	Occurred	Cleared
Info	Card Reconfigured	CBRE	7		08/24/00 01:41:17	08/24/00 01:41:17
Info	Card Reconfigured	UCMD	8		08/24/00 01:41:17	08/24/00 01:41:17
Major	Cellbus Parity Failed	CBRE	7		08/24/00 01:41:04	08/24/00 01:41:12
Info	Card Reconfigured	DS1	3		08/24/00 01:41:07	08/24/00 01:41:07
Info	Card Reconfigured	ENET	6		08/24/00 01:41:05	08/24/00 01:41:05
Major	Id Prom Checksum Error	NONE	8		08/24/00 01:41:04	08/24/00 01:41:04
Info	Card Reconfigured	SIM	5		08/24/00 01:41:03	08/24/00 01:41:03

Press Esc for previous menu or 'N' for next page. █

If the history file cannot be displayed on one page, the Display History Alarm screen will include a prompt to press *[n]* for the next page or press *[p]* for the previous page.

- 3 Use the print screen or other printing feature of your NMS station to print out each page of the history file.
- 4 Compare the printouts to your most previous records to see if there are any obvious trends, such as more frequent alarms of a certain type, which might require troubleshooting.

Clearing History Alarms

After you have printed the alarm history, you should clear the alarms so that they will no longer take up space in the alarm history file. To do this, follow these steps:

- 1 Return to the Fault Management menu.
- 2 Select *[4] Clear History Alarms*.
- 3 Enter **y** in response to the confirmation prompt to clear the history alarms.

Using Loopbacks

Loopbacks allow you to check circuit continuity between one point and another. You should use the PathBuilder S330/S310 loopback feature to check continuity to the nearest point first, and if the circuit is valid to that point, then loop to the next point. If a circuit has been compromised, isolating the problem between two points should help you identify and resolve the problem.

To access the loopback modes supported by the PathBuilder S330/S310, follow these steps:

- 1 From the Main menu, select [3] *Fault Management* to display the Fault Management menu shown earlier in Figure 133.
- 2 Select [5] *Loopback* from the Fault Management menu to display the Loopback menu, shown in Figure 136.

Figure 136 Loopback Menu

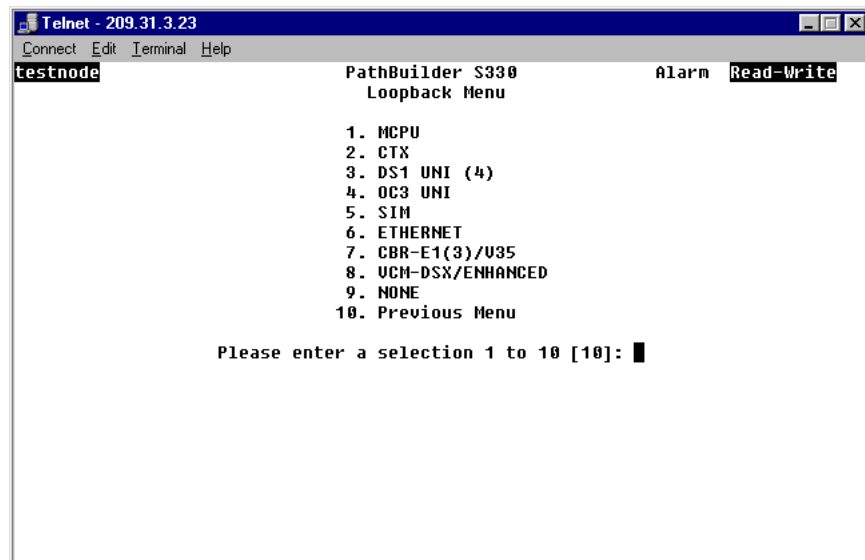

- 3 Select the card type for which you want to conduct the loopback. The Loopback menu for the selected port appears. Figure 137 shows the Loopback menu for the OC3/STM-1 port.



If you select a card type for which the PathBuilder S330/S310 does not support loopbacks, a message appears, informing you that no loopback feature is available for that card type.

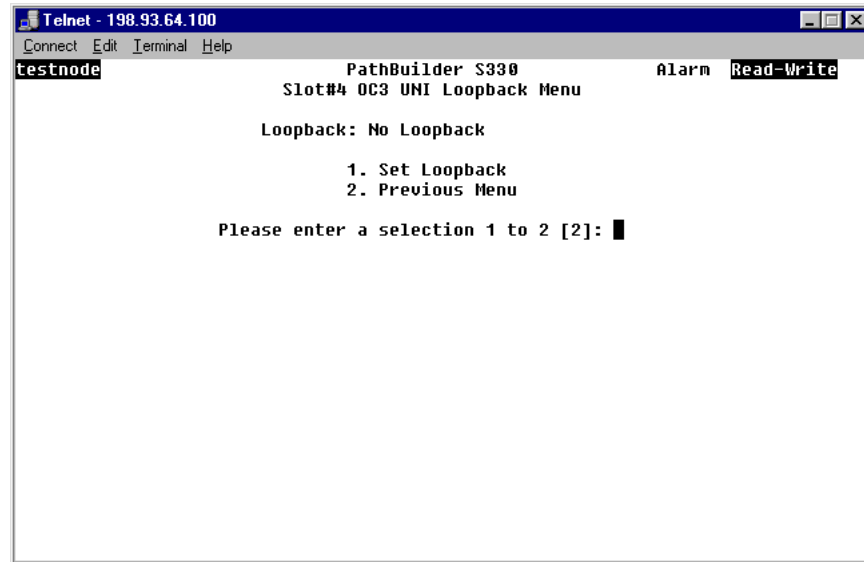

If you select a multiple-port card, you must also select the port for which you want to configure the loopback.

Figure 137 OC3/STM-1 Loopback Menu

- 4 Select *[1]* *Set Loopback*. A prompt listing the loopback choices for the selected port appears at the bottom of the screen.
- 5 Enter the number corresponding to the type of loopback you want to configure. The following subsections describe the available loopbacks for each of the PathBuilder S330 interfaces.

T1/E1 UNI Loopbacks

The following loopbacks are available for the T1/E1 UNI interface:

Network Line—Loops the T1/E1 received data back on the output side after the digital data has been recovered.

Local Card—Loops the transmit T1/E1 output on the receive side; the transmitted data will continue to go on the output.

Network Card—Loops the T1/E1 received payload back toward the line output.

illustrates the loopbacks for T1/E1.

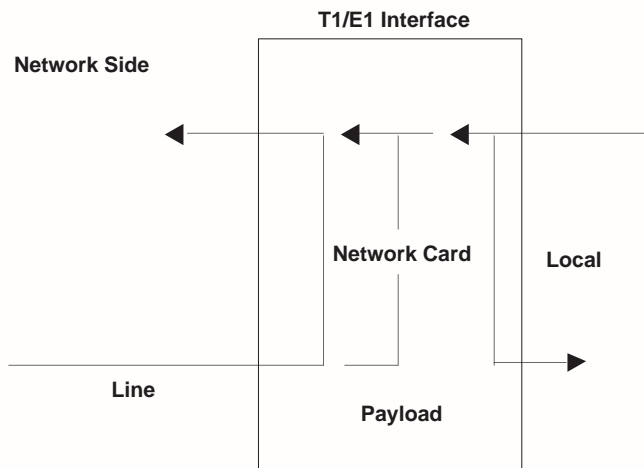
Figure 138 T1/E1 Loopbacks

OC3/STM-1 Loopbacks The following loopbacks are available for the OC3/STM-1 interface:

Network Line—Loops the OC3/STM-1 received data back on the output side after the digital data has been recovered.

Local Card—Loops the transmit OC3/STM-1 output on the receive side; the transmitted data will continue to go on the output.

Figure 139 illustrates the loopbacks for OC3/STM-1.

Figure 139 OC3/STM-1 Loopbacks

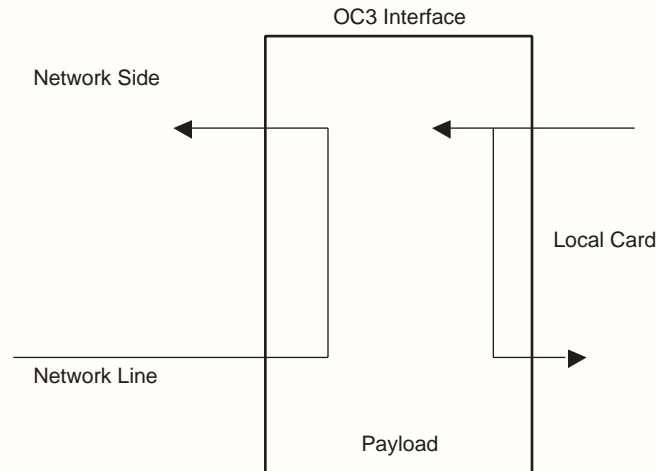

DS3 Loopbacks The DS3 module supports the following loopbacks:

Local Card—Loops the transmit DS3 output on the receive side. All cells coming from the DS3 card are looped through the backplane and back to the DS3 card. The transmitted data will continue to go on the output.

Network Line—Loops the DS3 received data back on the output side after the digital data has been recovered.

Network Card—Loops the DS3 received cell payload back toward the line output.

Figure 140 illustrates the DS3 loopback options.

Figure 140 DS3 UNI Loopback Options

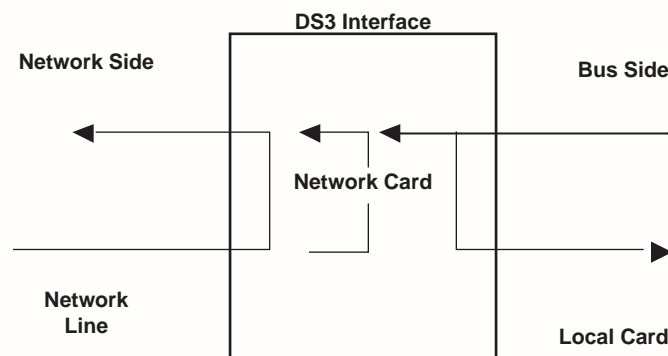

E3 Loopbacks The E3 module supports the following loopbacks:

Local Card—Loops the transmit E3 output on the receive side. All cells coming from the E3 port card are looped through the backplane and back to the E3 port card. The transmitted data will continue to go on the output.

Network Line—Loops the E3 received data back on the output side after the digital data has been recovered.

Network Card—Loops the E3 received cell payload back toward the line output.

Figure 141 illustrates the loopbacks for the E3 module.

Figure 141 E3 Loopback Options

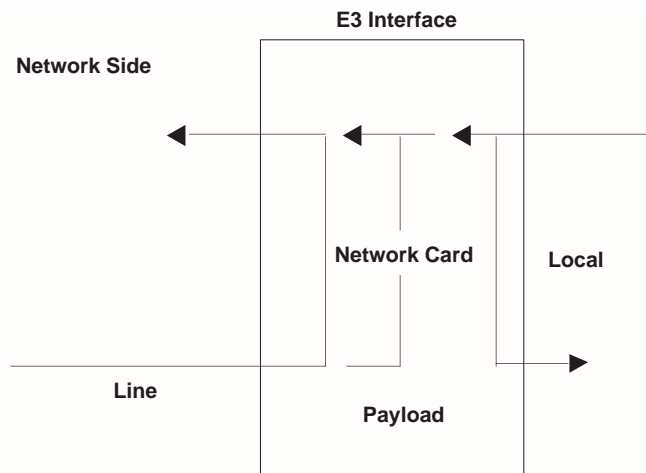

CBR Loopbacks The following loopbacks are available for the CBR module:

Network Line—Loops the T1-DSX received data back on the output side after the digital data has been recovered.

Local Card—Loops the transmit T1-DSX output on the receive side; the transmitted data will continue to go on the output.

Network Card—Loops the T1-DSX received payload back toward the line output.

Figure 142 illustrates the CBR T1-DSX loopbacks.

Figure 142 CBR Loopback

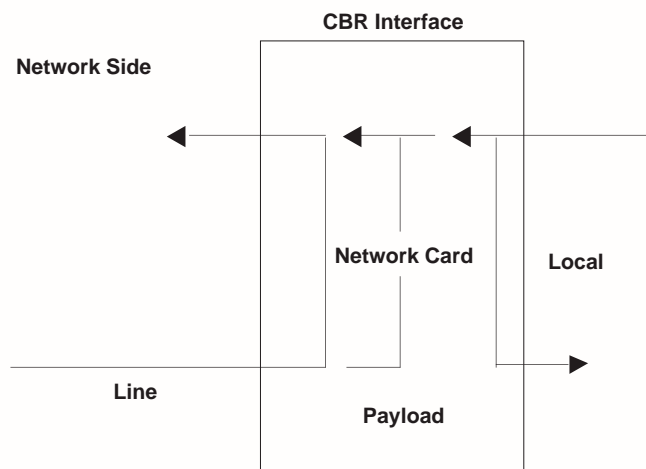

Setting VCM Loopbacks

For the Voice Compression module, you can set both card/line and channel loopbacks. When you set a VCM loopback, the MCPU sends a message to the VCM card to perform a maintenance function, and the VCM replies with an acknowledgment. When the VCM enters maintenance mode, it generates an alarm to the MCPU. Only one maintenance function per port or per channel is allowed.

Setting VCM Port Loopbacks

To set VCM port (card/line) loopbacks, follow these steps:

- 1 From the Loopback Menu, shown earlier in Figure 136, enter the number corresponding to the slot number in which the Voice Compression module is installed (**7** or **8**) to open the VCM Loopback menu. Figure 143 shows the VCM T1-DSX menu. The VCM E1 menu is the same.

Figure 143 VCM Loopback Menu

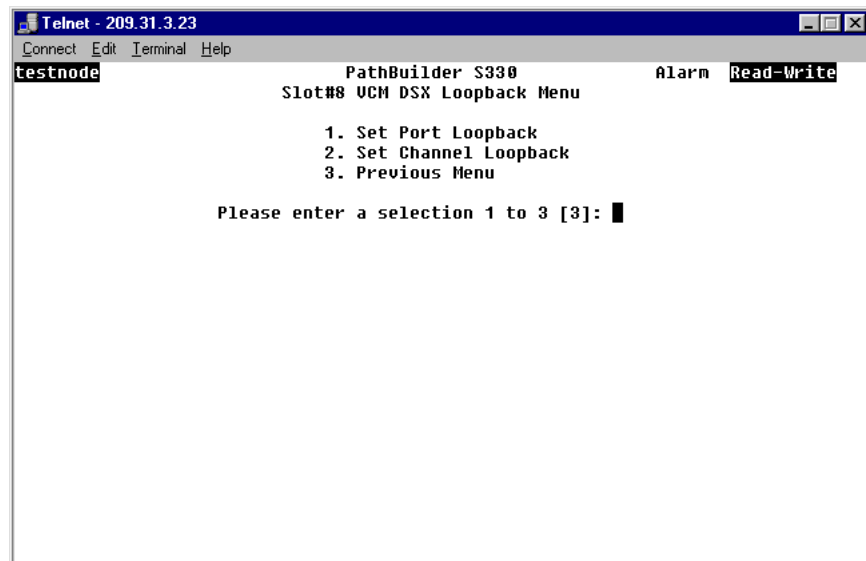

- 2 Select *[1] Set Port Loopback* to open the VCM Card/Line Loopback menu. This menu is similar to the OC3/STM-1 Loopback menu, shown earlier in Figure 139.
- 3 Select the option corresponding to the type of loopback you want to perform, and set the loopback to *On*.

Local Card—Loops the transmit VCM output on the receive side; the transmitted data will continue to go on the output.

Network Line—Loops the VCM received data back on the output side after the digital data has been recovered.

Network Card—Loops the T1-DSX received payload back toward the line output.

Setting VCM Channel Loopbacks

To set VCM channel loopbacks, follow these steps:

- 1 From the Loopback Menu, shown earlier in Figure 136, enter the number corresponding to the slot number in which the Voice Compression module is installed (**7** or **8**) to open the VCM Loopback menu.
- 2 From the VCM Loopback menu, shown in Figure 143, select *[2] Set Channel Loopback*.

The following prompt appears:

Enter Channel (1-8):

- 3 Enter the number of the channel for which you want to set a loopback to open the VCM Channel Loopback menu for that channel. Figure 144 shows the VCM T1-DSX Channel Loopback menu. The VCM E1 Channel Loopback menu is the same.

Figure 144 VCM Channel Loopback Menu

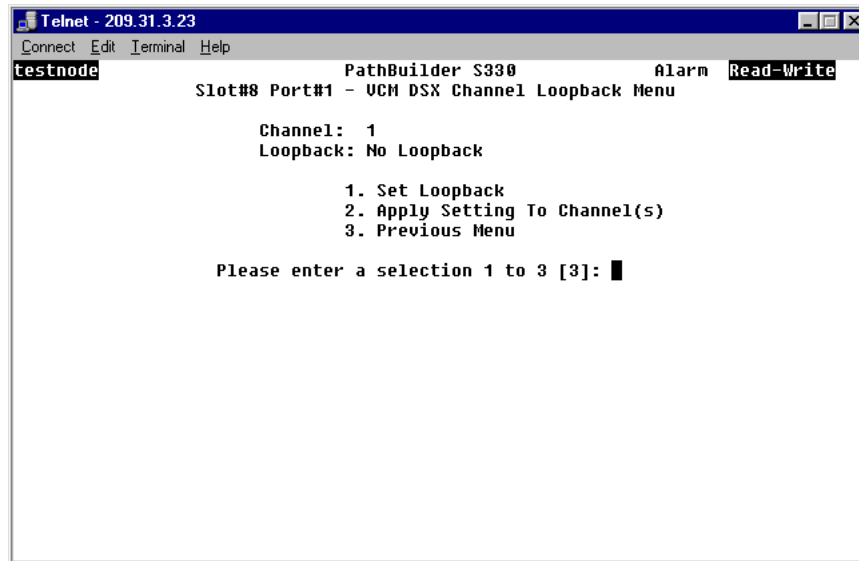

- 4 Select [1] Set Loopback. A prompt appears, listing the available types of channel loopback.
- 5 Enter the appropriate number to select one of the following types of channel loopbacks (or no loopback):

PCM Loopback—Loops digital receive to transmit toward the T1 port.

PCM Packet Loopback—Loops coder output to coder input toward the T1 port, using the DSP channel PCM packet loopback.

Network Packet Loopback—Loops coder input to coder output toward the ATM network, using the DSP channel network packet loopback.

- 6 Select [2] Apply Setting to Channel(s).

The following prompt appears:

Enter Channel (1-8):

- 7 Enter the number(s) of the channel(s) to which you want to apply the settings to set the specified loopback for those channels. You can enter a single channel, a range of channels (for example: **4-6**), or a list of channels separated by commas (for example: **4, 5, 6**).

Viewing Performance and ATM Statistics

This section tells you how to display the following types of PathBuilder S330/S310 statistics:

- Card Statistics
 - *Performance Monitoring* screens lists statistics that reflect the physical monitoring of the line. These screens display one of the following types of data.
 - Current**—The statistics being collected for the current 15-minute interval.
 - Interval**—The statistics collected over the previous 24 hours of operations, broken into 96 completed 15-minute intervals.
 - Total**—The cumulative sum of the various statistics for the 24-hour period preceding the current 15-minute interval.
 - *ATM* screens list statistics that monitor the ATM payload. These screens also display the date and time of the last reset and allow you to clear the currently-displayed statistics.
 - *Port Activity* screen (Voice Compression module) lists statistics that monitor VCM port activity.
- Virtual Circuit Statistics

Viewing Card Statistics

To view card statistics, follow these steps:

- 1 From the main menu, select **[4]** *Performance Management* to open the Performance Management Menu, shown in Figure 145.

Figure 145 Performance Management Menu

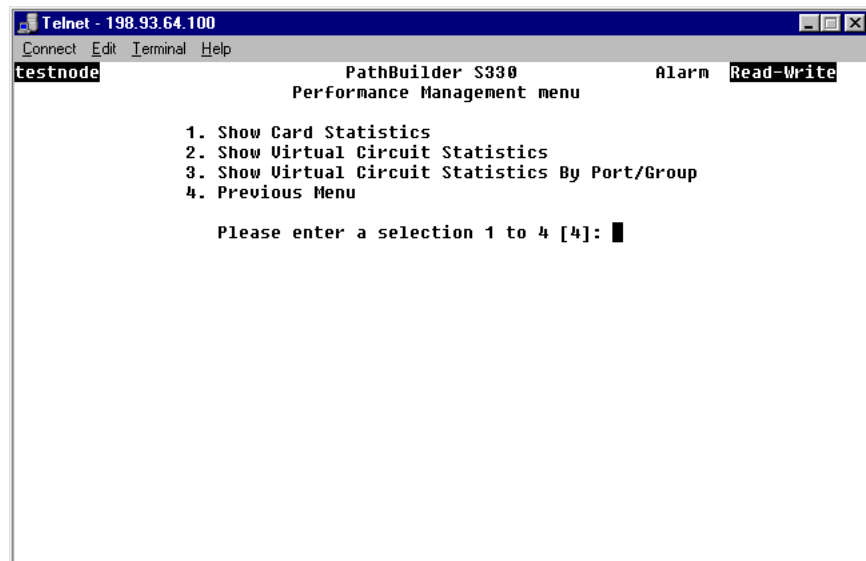

- 2 Select **[1]** *Card Statistics* to open the Card Statistics menu, shown in Figure 146.

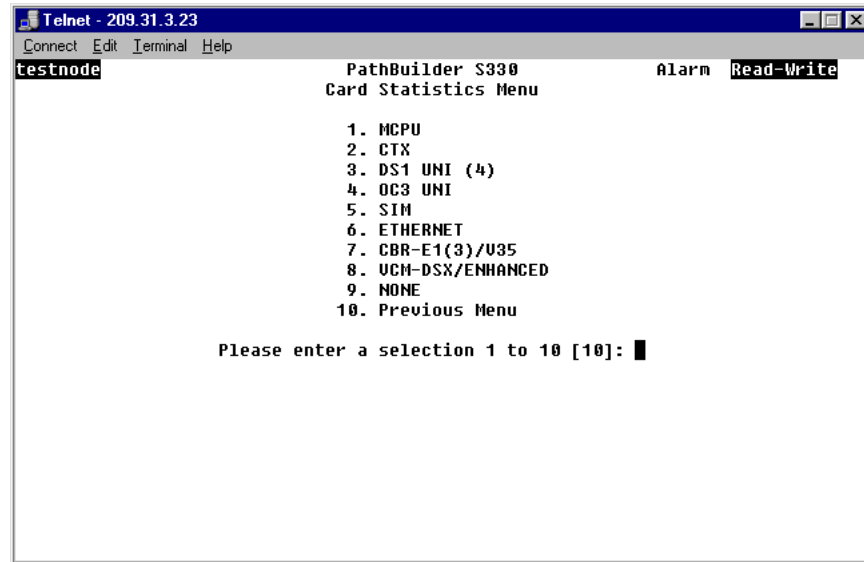
Figure 146 Card Statistics Menu

- 3 Enter the number corresponding to the card for which you want to view statistics.

The following sections describe the card statistics provided for each type of card.

Viewing T1/E1 UNI Card Statistics

You can view T1/E1 UNI statistics for ports or for groups.

To view T1/E1 statistics, follow these steps:

- 1 From the Card Statistics menu, shown earlier in Figure 146, select the option corresponding to the T1/E1 UNI module to open the T1/E1 UNI Performance menu.
- 2 Select [1] *Port/Link Performance Management* to view port statistics or [2] *Group Performance Management* to view group statistics.
- 3 Enter the number corresponding to the port or group for which you want to view statistics.
- 4 Select the option corresponding to the type of statistics you want to view.
 - Port statistics
 - PHY (Physical) Performance Monitoring
 - IMA Link Performance Monitoring
 - IMA Link ATM Statistics
 - Group statistics
 - Group performance
 - Group ATM

The following sections describe the statistics provided in each of these categories.



For performance monitoring statistics only, you must select the type of performance statistics you want to view: current, interval, or total. For details about these types of performance statistic, see "Viewing Performance and ATM Statistics" earlier in this chapter.

T1/E1 Port/Link Statistics

This section describes the T1/E1 port/link statistics.

T1/E1 Port/Link Physical Performance Statistics

The T1 (DS1)/E1 UNI Physical Performance Monitoring screen displays the following statistics.



You can view the statistics as current, interval, or total data.

ES—The number of errored seconds (ESs) encountered by the T1/E1 interface.

SES—The number of severely-errored seconds (SESS) encountered by the T1/E1 interface.

SEFS—The number of severely errored framing seconds (SEFSs) encountered by the T1/E1 interface.

UAS—The number of unavailable seconds (UASs) encountered by the T1/E1 interface.

CSS—The number of controlled slip seconds (CSSs) encountered by the T1/E1 interface.

PCV—The number of path coding violations (PCVs) encountered by the T1/E1 interface.

LES—The number of line errored seconds (LESs) encountered by the T1/E1 interface.

BES—The number of bursty errored seconds (BESs) encountered by the T1/E1 interface.

DM—The number of degraded minutes (DM) encountered by the T1/E1 interface.

LCV—The number of line coding violations (LCVs) encountered by the T1/E1 interface.

T1/E1 Port/Link IMA Link Performance Statistics The T1/E1 Link Performance Monitoring screen lists the following statistics:

IV-IMA—IMA violation; the number of errored, invalid, or missing ICP cells.

SES-IMA—Near end severely-errored seconds; the number of seconds with IMA violation, LOS, AIS, OOF, LCD, LIF, LODS at the near end.

SES-IMA-FE—Far end severely-errored seconds; the number of seconds with IMA violation, LOS, AIS, OOF, LCD, LIF, LODS at the far end.

UAS-IMA—Near end unavailable seconds; the number of unavailable seconds at the near end.

UAS-IMA-FE—Far end unavailable seconds; the number of unavailable seconds at the far end.

Tx-UUS-IMA—Near end transmit unusable seconds; the number of unusable seconds at the near end interworking Tx link state machine.

Rx-UUS-IMA—Near end receive unusable seconds; the number of unusable seconds at the near end interworking Rx link state machine.

Tx-UUS-IMA-FE—Far end transmit unusable seconds; the number of unusable seconds at the far end interworking Tx link state machine.

Rx-UUS-IMA-FE—Far end receive unusable seconds; the number of unusable seconds at the far end interworking Rx link state machine.

Tx-FC—Number of near-end transmit failures.

Rx-FC—Number of near-end receive failures.

Tx-FC-FE—Number of far-end transmit failures.

Rx-FC-FE—Number of far-end receive failures.

T1/E1 Port/Link IMA Link ATM Statistics The T1/E1 Link ATM Statistics screen lists the following statistics:

Tx Cells—The number of cells transmitted in a port/group since the counter was cleared.

Rx Cells—The number of cells received in a port/group since the counter was cleared.

Rx ICP Cell Error—The number of ICP cells received in a port/group since the counter was cleared.

Tx Cell Rate—Current transmitted data cells rate.

Rx Cell Rate—Current received data cells rate.

Rx ICP Cell Error Rate—Current ICP received cell error rate.

Avg. Tx Cell Rate—Average received data cells rate calculated over the last 8 seconds.

Avg. Rx Cell Rate—Average transmitted data cells rate calculated over the last 8 seconds.

Avg. Rx ICP Cell Error Rate—Average received errored ICP cells rate calculated over the last 8 seconds.

T1/E1 Group Statistics

This section describes the T1/E1 group statistics.

T1/E1 Group Performance Statistics The T1/E1 Group Performance screen lists the following statistics:

Running Seconds—The amount of time (in seconds) since the IMA group has been in operation (up or down).

Unavailable Seconds—Count of unavailable seconds at the near end interworking group state machine.

NE Number of Failures—Number of times a near end group failure has been reported since powerup or reboot.

FE Number of Failures—Number of times a far end group failure has been reported since powerup or reboot.

T1/E1 Group ATM Statistics The T1/E1 Group ATM Statistics screen lists the following statistics:

Tx cells—The number of cells transmitted in a group since the counter was cleared.

Rx cells—The number of cells received in a group since the counter was cleared.

Rx ICP cell errors—The number of cells received in a port/group since the counter was cleared.

Tx cell rate—Current transmitted data cells rate.

Rx cell rate—Current received data cells rate.

Rx ICP cell error rate—Current ICP received cell error rate.

Avg. Tx cell rate—Average transmitted data cells rate calculated over the last 8 seconds.

Avg. Rx cell rate—Average received data cells rate calculated over the last 8 seconds.

Avg. ICP cell error rate—Average received errored ICP cells rate calculated over the last 8 seconds.

Viewing OC3/STM-1 Card Statistics

You can view both performance statistics and ATM statistics for the OC3/STM-1 port.

Viewing OC3/STM-1 Performance Statistics

To view OC3/STM-1 performance statistics, follow these steps:

- 1 From the Card Statistics menu, select *[4] OC3/STM-1 UNI*. The OC3/STM-1 Performance Management menu appears.
- 2 Select *[1] OC3/STM-1 Performance Monitoring*. The OC3/STM-1 Performance Management menu appears as shown in Figure 147.

Figure 147 OC3/STM-1 Performance Management Menu

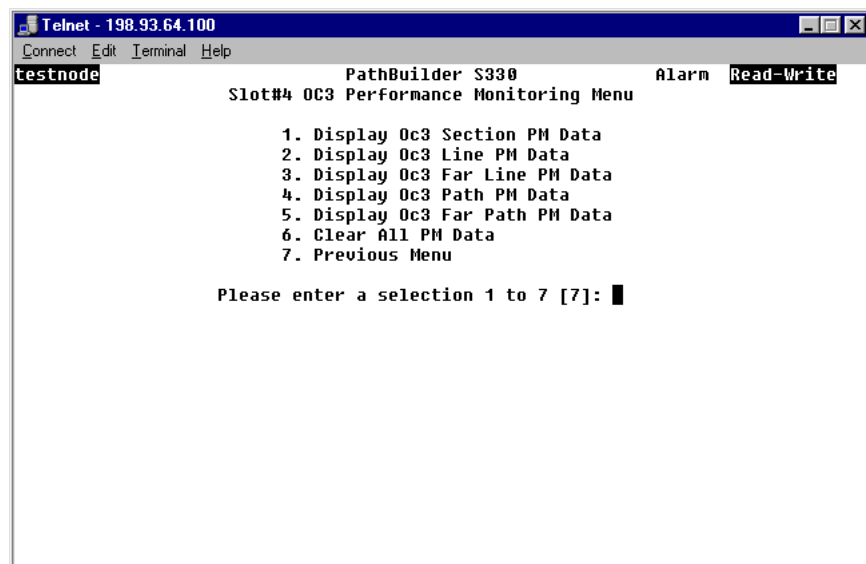

- 3 Select the option corresponding to the type of performance monitoring (PM) data you want to view: section, line, far line, path, or far path.
- 4 Select the option corresponding to the type of data you want to display (current, interval, or total). The OC3/STM-1 Performance Monitoring screen displays the current, interval, or total data for the type of statistic you selected in step 2b.

The following subsections list the statistics displayed for each of these types of performance monitoring.

OC3/STM-1 Section Performance Statistics The OC3/STM-1 Section Performance Monitoring screen displays the following statistics:

ES—The number of errored seconds (ESs) encountered by the OC3/STM-1 section.

SES—The number of severely-errored seconds (SEs) encountered by the OC3/STM-1 section.

SEFS—The number of severely errored framing seconds (SEFSs) encountered by the OC3/STM-1 section.

CVS—The number of coding violations (CVs) encountered by the OC3/STM-1 section.

LOS—The number of Loss of Signal (LOS) conditions encountered by the OC3/STM-1 section.

LOF—The number of Loss of Frame (LOF) conditions encountered by the OC3/STM-1 section.

OC3/STM-1 Line Performance Statistics The OC3/STM-1 Line Performance Monitoring screen displays the following statistics:

ES—The number of errored seconds (ESs) encountered by the OC3/STM-1 line.

SES—The number of severely-errored seconds (SEs) encountered by the OC3/STM-1 line.

UAS—The number of unavailable seconds (UASs) encountered by the OC3/STM-1 line.

CVS—The number of coding violations (CVs) encountered by the OC3/STM-1 line.

AIS—Indicates whether or not an Alarm Indicator Signal (AIS) condition has been encountered by the OC3/STM-1 line.

RDI—Indicates whether or not a Remote Defect Indication (RDI) condition has been encountered by the OC3/STM-1 interface. Also known as FERF (Far End Receive Failure). This is the alarm that is generated when a far end AIS or LOP defect is detected.

OC3/STM-1 Far Line Performance Statistics The OC3/STM-1 Far Line Performance Monitoring screen displays the following statistics:

ES—The number of far end errored seconds (ESs) encountered by the OC3/STM-1 interface.

SES—The number of far end severely-errored seconds (SEs) encountered by the OC3/STM-1 interface.

UAS—The number of far end unavailable seconds (UASs) encountered by the OC3/STM-1 interface.

CVS—The number of far end coding violations (CVs) encountered by the OC3/STM-1 interface.

OC3/STM-1 Path Performance Statistics The OC3/STM-1 Path Performance Monitoring screen displays the following statistics:

ES—The number of errored seconds (ESs) encountered by the OC3/STM-1 path interface.

SES—The number of severely-errored seconds (SEs) encountered by the OC3/STM-1 path interface.

UAS—The number of unavailable seconds (UASs) encountered by the OC3/STM-1 path interface.

CVS—The number of coding violations (CVs) encountered by the OC3/STM-1 path interface.

LOP—Indicates whether or not a Loss of Pointer (LOP) condition has been encountered by the OC3/STM-1 path interface.

AIS—Indicates whether or not an Alarm Indicator Signal (AIS) condition has been encountered by the OC3/STM-1 path interface.

RDI—Indicates whether or not a Remote Defect Indication (RDI) condition has been encountered by the OC3/STM-1 path interface. Also known as FERF (Far End Receive Failure). This is the alarm that is generated when a far end AIS or LOP defect is detected.

UEQ—Indicates whether or not an Unequipped (UEQ) condition has been encountered by the OC3/STM-1 path interface. If a path is not provisioned (i.e. it is idle), the SONET equipment will signal this state.

PLM—Physical Layer Module.

OC3STM-1 Far Path Performance Statistics The OC3/STM-1 Far Path Performance Monitoring screen displays the following statistics:

ES—The number of far end errored seconds (ESs) encountered by the OC3/STM-1 path interface.

SES—The number of far end severely-errored seconds (SEs) encountered by the OC3/STM-1 path interface.

UAS—The number of far end unavailable seconds (UASs) encountered by the OC3/STM-1 path interface.

CVS—The number of far end coding violations (CVs) encountered by the OC3/STM-1 path interface.

Viewing OC3/STM-1 ATM Statistics

To view OC3/STM-1 ATM statistics, follow these steps:

- 1 From the Performance Management menu, select [4] OC3/STM-1 UNI. The OC3/STM-1 Performance Management menu appears.
- 2 Select [2] *ATM Statistics*. ATM cell statistics are cell counts since the last counter reset. On the OC3/STM-1 ATM Statistics screen, you can reset the counter by entering [c].

The OC3/STM-1 ATM Statistics menu provides the following information:

Cells Received—The number of ATM cells received on the OC3/STM-1 since the last user reset of this counter.

Cells transmitted—The number of ATM cells transmitted on the OC3/STM-1 since the last user reset of this counter.

Cells with uncorrectable HCS errors—The number of idle/unassigned cells encountered and dropped on the interface due to uncorrectable HCS errors.

Cells with correctable HCS errors—The number of header check sequence (HCS) errored cells encountered on the ATM interface.

Viewing DS3 Card Statistics You can view both performance statistics and ATM statistics for the DS3 UNI module.

Viewing DS3 UNI Performance Statistics

To view DS3 UNI performance statistics, follow these steps:

- 1 From the Card Statistics menu, select [9] *DS3 UNI* to open the DS3 UNI Performance Management menu. This menu is similar to the OC3/STM-1 Performance Management menu, shown earlier in Figure 147.
- 2 Select [1] *DS3 UNI Performance Monitoring* to open the DS3 Performance Monitoring menu. The DS3 Performance Monitoring menu provides the following information:

PES—The number of P-bit errored seconds (PESs) encountered by the DS3 interface.

PSES—The number of P-bit severely errored seconds (PSESs) encountered by the DS3 interface.

SEFS—The number of severely errored framing seconds (SEFSs) encountered by the DS3 interface.

UAS—The number of unavailable seconds (UASs) encountered by the DS3 interface.

LCV—The number of line coding violations (LCVs) encountered by the DS3 interface.

PCV—The number of path coding violations (PCVs) encountered by the DS3 interface.

LES—The number of line errored seconds (LESs) encountered by the DS3 interface.

CCV—The number of C-bit coding violations (CCVs) encountered by the DS3 interface.

CES—The number of C-bit errored seconds (CESs) encountered by the DS3 interface.

CSES—The number of C-bit severely errored seconds (CSESs) encountered by the DS3 interface.

Viewing DS3 UNI ATM Statistics

To view DS3 ATM statistics, follow these steps:

- 1 From the Card Statistics menu, select [9] *DS3 UNI* to open the DS3 Performance Management menu.
- 2 From the DS3 Performance Management menu, select [2] *ATM Statistics*. ATM cell statistics are cell counts since the last counter reset. On the DS3 ATM Statistics screen, you can reset the counter by entering [c].

The DS3 ATM Statistics menu provides the following information:

Cells Received—The number of ATM cells received on the DS3 since the last user reset of this counter.

Cells transmitted—The number of ATM cells transmitted on the DS3 since the last user reset of this counter.

Cells dropped—The number of idle/unassigned cells encountered and dropped on the interface.

Cells with HCS errors—The number of header check sequence (HCS) errored cells encountered on the ATM interface.

Viewing E3 Card Statistics

You can view both performance statistics and ATM statistics for the E3 UNI module.

Viewing E3 UNI Performance Statistics

To view E3 UNI performance statistics, follow these steps:

- 1 From the Card Statistics menu, select *[9] E3 UNI* to open the E3 UNI Performance Management menu. This menu is similar to the OC3/STM-1 Performance Management menu, shown earlier in Figure 147.
- 2 Select *[1] E3 UNI Performance Monitoring* to open the E3 Performance Management menu. The E3 Performance Management menu provides the following information:

SEFS—The number of severely errored framing seconds (SEFSs) encountered by the E3 interface.

LCV—The number of line coding violations (LCVs) encountered by the E3 interface.

LES—The number of line errored seconds (LESs) encountered by the E3 interface.

Viewing E3 UNI ATM Statistics

To view E3 ATM statistics, follow these steps:

- 1 From the Card Statistics menu, select *[9] E3 UNI* to open the E3 Performance Management menu.
- 2 From the E3 Performance Management menu, select *[2] ATM Statistics*. ATM cell statistics are cell counts since the last counter reset. On the E3 ATM Statistics screen, you can reset the counter by entering *[c]*.

The E3 ATM Statistics menu provides the following information:

Cells Received—The number of ATM cells received on the E3 since the last user reset of this counter.

Cells transmitted—The number of ATM cells transmitted on the E3 since the last user reset of this counter.

Cells dropped—The number of idle/unassigned cells encountered and dropped on the interface.

Cells with HCS errors—The number of header check sequence (HCS) errored cells encountered on the ATM interface.

Viewing SIM Card Statistics

You can view HDLC, Frame Relay, and ATM VC statistics for the serial port. To view serial port statistics, follow these steps:

- 1 From the Card Statistics menu, shown earlier in Figure 146, select *[5] SIM*. The SIM Statistics menu appears.
- 2 Select *[1] Port 1*.
- 3 Select the option corresponding to the type of statistics you want to view.

SIM HDLC Statistics

SIM HDLC statistics include:

Received Frames—The total number of received frames with good FCS at this port.

Transmitted Frames—The total number of successfully-transmitted frames at this port.

Discarded Invalid Frames—The total number of frames discarded at this port because they were invalid. Invalid frames are frames that are received with good FCS but that cannot be processed due to wrong content.

Discarded Congested Frames—The total number of frames discarded at this port because they were congested. Congested frames are frames that were not transmitted due to link congestion.

Received bytes—The total number of bytes received at this port.

Transmitted bytes—The total number of bytes transmitted at this port.

FCS Errors—The total number of received frames with bad FCS at this port.

SIM Frame Relay Statistics

SIM Frame Relay statistics include:

VC#—The system-assigned virtual circuit number.

(Side A) card s/p—The slot and port number for side A of the circuit.

(Side A) rx—The receive VCI/VPI for side A.

(Side A) tx—The transmit VCI/VPI for side A.

(Side B) card s/p—The slot and port number for side B of the circuit.

(Side B) rx—The receive VCI/VPI for side B.

(Side B) tx —The transmit VCI/VPI for side B.

(Side B) Desc—The user-entered description of the circuit.

SIM ATM VC Statistics

SIM ATM VC statistics include:

VC#—The system-assigned virtual circuit number.

(Side A) card s/p—The slot and port number for side A of the circuit.

(Side A) rx—The receive VCI/VPI for side A.

(Side A) tx—The transmit VCI/VPI for side A.

(Side B) card s/p—The slot and port number for side B of the circuit.

(Side B) rx—The receive VCI/VPI for side B.

(Side B) tx —The transmit VCI/VPI for side B.

Desc—The user-entered description of the circuit.

Viewing Ethernet Card Statistics

Ethernet statistics are collected according to the Ethernet bridge MIB on the Ethernet port and on every ATM connection tied to this port. You can view bridge, filtering, and Ethernet statistics, and you can also view ATM VC statistics for the Ethernet port.

To view Ethernet port statistics, follow these steps:

- 1 From the Card Statistics menu, shown earlier in Figure 146, select *[6] ETHERNET*.
- 2 Select *[1] Port 1*.
- 3 Select the option corresponding to the type of statistic you want to view: *[1] Ethernet Statistics* or *[2] ATM Statistics*.

Ethernet Statistics

The Ethernet Statistics screen displays the following statistics:

Bridge Statistics

Port state—The state of the Ethernet port: connected or not connected.

Total frames received—The total number of frames received at this port.

Broadcast Frames—The number of broadcast frames received on the port.

Discarded Frames—The number of valid frames received that were discarded (filtered) by the forwarding process.

Flooded Frames—The total number of incoming frames that were flooded on this port.

Forwarded Frames—The number of incoming frames at this port that were forwarded.

Total frames transmitted—The total number of frames transmitted at this port.

Filtering Statistics

MAC MTU Exceeded—The number of frames discarded because of a size greater than the maximum MTU size for the port.

No ATM VCs present—The number of frames discarded because there was no ATM VC associated with the physical port.

Bridge discards—The number of frames discarded due to the bridging operation.

Output port disabled—The number of frames discarded because the output port was disabled.

Source address filtered—The number of frames discarded due to source address filtering.

Destination address filtered—The number of frames discarded due to destination address filtering.

SAP Filtered—The number of frames discarded due to the protocol filtering operation.

Ethernet Statistics

Transmitted Frames—The total number of frames transmitted at this port.

Transmitted bytes—The total number of bytes transmitted at this port.

Received Frames—The total number of frames received at this port.

Received bytes—The total number of bytes received at this port.

CRC errored frames—The number of frames with CRC errors detected at this port.

Late collisions—The number of times that a collision has been detected on this port later than 512 bit-times into the transmission of a packet.

Deferred transmits—The number of frames for which the first transmission attempt at this port was delayed because the port was busy. This count does not include frames involved in collisions.

Single collisions—The number of successfully-transmitted frames at this port for which transmission is inhibited by exactly one collision.

Multiple collisions—The number of successfully-transmitted frames at this port for which transmission is inhibited by more than one collision.

Excessive collisions—The number of frames for which transmission at this port failed due to excessive collisions.

Carrier sense errors—The number of times that the carrier sense condition was lost or never asserted when attempting to transmit a frame at this port.

Internal transmit errors—The number of frames for which reception at this port failed due to an internal MAC sublayer receive error.

Oversized frames—The number of frames received at this port that exceeded the maximum permitted frame size.

The Ethernet ATM Statistics screen displays the following ATM VC statistics for the Ethernet port:

VC#—The system-assigned virtual circuit number.

(Side A) card s/p—The slot and port number for side A of the circuit.

(Side A) rx—The receive VCI/VPI for side A.

(Side A) tx—The transmit VCI/VPI for side A.

(Side B) card s/p—The slot and port number for side B of the circuit.

(Side B) rx—The receive VCI/VPI for side B.
(Side B) tx—The transmit VCI/VPI for side B.

(Side B) Desc—The user-entered description of the circuit.

Spanning Tree Statistics

The Spanning Tree Statistics screen displays the following statistics:

Bridge Identifier—The bridge address of the Ethernet port.

Root Bridge—The bridge root address of the Ethernet port.

Designated Bridge ID—The designated Spanning Tree bridge ID of this port.

Hello Time—The time interval between issuing STP (Spanning Tree Protocol) configuration messages.

Forward Delay—The amount of time in the “learning” and “listening” states; half the amount of time that must elapse between the time when it is decided that a port should become part of the Spanning Tree and the time when data traffic is allowed to be forwarded to and from that port.

Maximum Age—The time at which a configuration message is discarded.

Port Identifier—The bridge root port of the Ethernet port.

Root Path Cost—The bridge root path cost of the Ethernet port.

Designated Port ID—The designated Spanning Tree bridge port ID of this port.

Topology Changed—The topology change state of Spanning Tree for this port.

Topology Changed Count—The number of topology changes of Spanning Tree for this port.

Total Forward Transitions—The total number of times this port has transitioned from the learning state to the forwarding state.

Total BridgeUp Time—The total amount of time that this port has been up as part of the Spanning Tree bridge.

Viewing CBR Module Card Statistics

You can view both performance monitoring and ATM statistics for the CBR module. To view CBR statistics, follow these steps:

- 1 From the Card Statistics menu, shown earlier in Figure 146, select *[7] CBR*.
- 2 Select the port for which you want to view statistics.
- 3 Enter the option corresponding to the type of statistics you want to view: *[1] Performance Monitoring* or *[2] ATM Statistics*.

CBR Performance Monitoring Statistics

The CBR Performance Monitoring screens display the following statistics:

ES—The number of errored seconds (ESs) encountered by the CBR T1-DSX/E1 interface.

SES—The number of severely-errored seconds (SESSs) encountered by the CBR T1-DSX/E1 interface.

SEFS—The number of severely errored framing seconds (SEFSs) encountered by the CBR T1-DSX/E1 interface.

UAS—The number of unavailable seconds (UASs) encountered by the CBR T1-DSX/E1 interface.

CSS—The number of controlled slip seconds (CSSs) encountered by the CBR T1-DSX/E1 interface.

PCV—The number of path coding violations (PCVs) encountered by the CBR T1-DSX/E1 interface.

LES—The number of line errored seconds (LESs) encountered by the CBR T1-DSX/E1 interface.

BES—The number of bursty errored seconds (BESs) encountered by the CBR T1-DSX/E1 interface.

DM—The number of degraded minutes (DMs) encountered by the CBR T1-DSX/E1 interface.

LCV—The number of line coding violations (LCVs) encountered by the CBR T1-DSX/E1 interface.

CBR ATM Statistics

ATM cell statistics are cell counts since the last counter reset. On the ATM Statistics window, you can reset the counter by entering **c**. ATM statistics are displayed as a list rather than a table. The CBR T1-DSX and CBR E1 ATM Statistics screens display the following statistics:



CBR virtual circuits must be present in the database in order to view these statistics.

Total Cells Received—Total number of cells received over the virtual circuit.

Total Cells Transmitted—Total number of cells transmitted over the virtual circuit.

Total Cell Pointer Errors—Number of cells dropped due to structure pointer mismatches.

Total Cells Lost—The difference between the number of cells transmitted and the number of cells received.

Total Number of Buffer Underflows—Number of buffer underflows over the virtual circuit.

Total Number of Buffer Overflows—Number of buffer overflows over the virtual circuit.

Total out of Sequence Errors—Number of cells received with out-of-sequence number mismatch.

Total CRC Errors—Number of cells received with uncorrectable sequence number CRC error.

Total OAM Cells Received—Number of OAM (Operations, Administration, and Maintenance) cells received over the virtual circuit. These cells carry OAM information used for network management.

Total OAM Cells Transmitted—Number of Operations Administration and Maintenance (OAM) cells transmitted over the virtual circuit.

Current Cell Status—Cell loss period count (for CBR use only).

Data Bytes To (structured data ports only)—The data bytes to the cell bus. Use this value to set the *DBA Bits Mask* CBR port parameter. In most cases, the default *DBA Bits Mask* (127) is appropriate. If you are experiencing problems with a CCS circuit, however, you can set the *DBA Bits Mask* to monitor different bits. Check the *Data Bytes To* value, and set the *DBA Bits Mask* to that value.



When you check the data bytes, you must first make sure that the circuit is in an idle state (phone onhook). If you cannot access the equipment to see whether or not the circuit is in idle, then check the data bytes for at least 30 seconds (about seven updates). If the Data Bytes To value remains the same for 30 seconds or more, it is safe to assume that the circuit is in an idle state.

Viewing Voice Compression Module Statistics

You can view performance monitoring, virtual circuit, and port activity statistics for the Voice Compression module. To view VCM statistics, follow these steps:

- 1 From the Card Statistics menu, shown earlier in Figure 146, enter the number corresponding to the slot in which the VCM for which you want to view statistics is installed (**7** or **8**) to open the VCM Card Statistics menu, shown in Figure 148.

Figure 148 VCM Card Statistics Menu

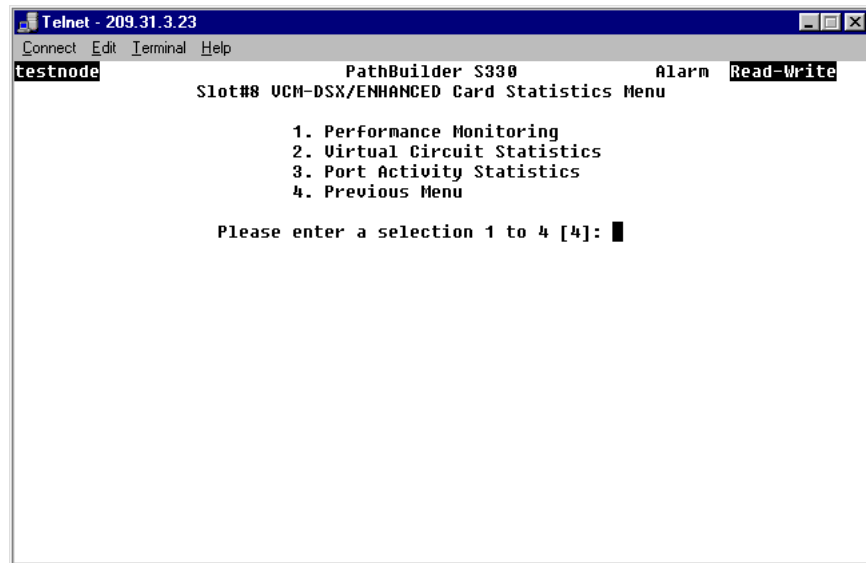

- 2 Select the option corresponding to the type of statistics you want to view: [1] Performance Monitoring, [2] Virtual Circuit Statistics, or [3] Port Activity Statistics.



If you select [2] VC Statistics, an additional screen appears from which you must select the virtual circuit for which you want to view statistics.

Voice Compression Module Performance Monitoring Statistics

The VCM Performance Monitoring screens display the following statistics:

ES—The number of errored seconds (ESs) encountered by the VCM T1-DSX/E1 interface.

SES—The number of severely-errored seconds (SEs) encountered by the VCM T1-DSX/E1 interface.

SEFS—The number of severely errored framing seconds (SEFSs) encountered by the VCM T1-DSX/E1 interface.

UAS—The number of unavailable seconds (UASs) encountered by the VCM T1-DSX/E1 interface.

CSS—The number of controlled slip seconds (CSSs) encountered by the VCM T1-DSX/E1 interface.

PCV—The number of path coding violations (PCVs) encountered by the VCM T1-DSX/E1 interface.

LES—The number of line errored seconds (LESs) encountered by the VCM T1-DSX/E1 interface.

BES—The number of bursty errored seconds (BESs) encountered by the VCM T1-DSX/E1 interface.

DM—The number of degraded minutes (DMs) encountered by the VCM T1-DSX/E1 interface.

LCV—The number of line coding violations (LCVs) encountered by the VCM T1-DSX/E1 interface.

Voice Compression Module VC Statistics

Voice compression module VC statistics are frame and byte counts since the last counter reset. On the VCM VC Statistics window, you can reset the counter by entering **c**. VC statistics are displayed as a list rather than a table. The VCM T1-DSX and VCM E1 VC Statistics screens display the following statistics:

Received Frames—Total number of frames received over the virtual circuit.

Transmitted Frames—Total number of frames transmitted over the virtual circuit.

AAL5 Errors—The total number of invalid frames received over the virtual circuit. Invalid frames are frames that are received with good FCS but that cannot be processed due to wrong content.

Discarded Congested Frames—The total number of frames received over the virtual circuit that were discarded due to congestion. Congested frames are frames that were not transmitted due to link congestion.

Voice Compression Module Port Activity Statistics

The VCM Port Activity Statistics screen displays the following statistics for each channel.

ch—Channel number.

tx packets—Number of transmitted packets.

rx packets—Number of received packets.

tx bytes—Number of transmitted bytes.

rx bytes—Number of received bytes.

Viewing Virtual Circuit Statistics

The PathBuilder S330/S310 provides you with circuit parameters and cell counts broken down in various ways:

- by circuit
- by port/group
- by shaper
- by buffer (queue)

These statistics enable you to look at the cell loss at various points in the data flow and adjust parameters—such as shaper values—accordingly.

Viewing Virtual Circuit Statistics by Circuit

To display virtual circuit statistics by circuit, follow these steps:

- 1 From the Configuration Management menu, select [2] *Manage Circuits* to display the Virtual Circuit menu.
- 2 From the Virtual Circuit menu, select [5] *Show Virtual Circuit Statistics* to display a summary of statistics for all circuits, as shown in Figure 149.

Figure 149 Virtual Circuit Statistics Summary Screen

UC#	Side A card	s/p	rx	tx	Side B card	s/p	rx	tx	Description
		rcvd	from	dropped					
1	MCPU	1	IP:234.56.78.9	0	OC3	4	0/2	0/2	testcircuit3
2	OC3	4	0/1	0/1	DS1	3/1	0/1	0/1	testcircuit1
3	SIM	5	DLCI:16	0	DS1	3/1	0/2	0/2	testcircuit2

Enter item# (1..3), for Detailed Statistics,
c to clear ALL statistics, ESC for previous menu:

Each pair of rows on the Virtual Circuit Statistics Summary screen provides the following information about one of the existing virtual circuits:

Row 1 (left to right)

- virtual circuit number
- side A card type
- side A slot and port numbers (IP address for the MCPU card)
- side A receive VCI/VPI
- side A transmit VCI/VPI
- side B card type
- side B slot and port numbers (IP address for the MCPU card)
- side B receive VCI/VPI
- side B transmit VCI/VPI
- virtual circuit description

Row 2 (left to right)

- cells received on side A
- cells dropped on side A
- cells received on side B
- cells dropped on side B

To view additional information about a particular circuit, enter the desired virtual circuit number. In addition to the information displayed on the summary screen, the Virtual Circuit Statistics Detail screen displays the number of cells sent on each side of the selected circuit.

Viewing Virtual Circuit Statistics by Port/Group

To display statistics for all virtual statistics by port/group, follow these steps:

- 1 From the Configuration Management menu, select *[2] Manage Circuits* to display the Virtual Circuit menu.
- 2 From the Virtual Circuit menu, select *[6] Show Virtual Statistics by Port/Group* to view a summary of statistics for all circuits on each port/group. The Port/Group Virtual Statistics summary screen displays the following information for each port/group:

Port/Group—Card type and port/group number.

rcvd from—Number of cells received

dropped—Number of received cells dropped

rcvd for—Number of cells sent

dropped—Number of sent cells dropped

To view the number of cells received, dropped, and sent from and to a particular port/group, enter the desired port/group number.

Viewing Virtual Circuit Statistics by Shaper

To display virtual circuit statistics by shaper, follow these steps:

- 1 From the Configuration Management menu, select *[1] Manage Card* to display the List Card menu.
- 2 Select *[2] CTX* to display the CTX menu.
- 3 From the CTX menu, select *[4] VC Statistics by Shaper* to display counts of cells sent and cells dropped for each shaper, as shown in Figure 150.

Figure 150 Virtual Circuit Statistics by Shaper Summary Screen

```

Telnet - 198.93.64.100
Connect Edit Terminal Help
testnode PathBuilder S330 Alarm Read-Write
UC Statistics By Shaper

Shaper      rcvd for    dropped
-----
1) Trunk Bulk      0           0
2) Trk Grp 1 Q3   0           0
3) SAR Output     0           0
4) OC3 Bulk       0           0
5) OC3 Q3         0           0

Enter item# (1..5) for details, c to clear ALL statistics,
ESC for previous menu: █

```

- 4 To view statistics for a single shaper, enter the desired shaper number. As shown in Figure 151, the Virtual Statistics by Shaper detail screen lists the number of cells received, dropped, and sent on the selected shaper.

Figure 151 Virtual Circuit Statistics by Shaper Detail Screen

```

Telnet - 198.93.64.100
Connect Edit Terminal Help
testnode PathBuilder S330 Alarm Read-Write
UC Statistics For SAR Output

Cells On Shaper

Received: 0
Dropped: 0
Sent: 0

Press c to clear ALL statistics, v to show UCs,
p to sum by port, ESC for previous menu: █

```

- 5 To view virtual circuit statistics by circuit for the selected shaper, enter **v** from the Virtual Circuit Statistics by Shaper Detail screen. The screen that appears displays the same information as the Show Virtual Statistics Summary screen shown earlier in Figure 149—except that it lists information only for circuits on the selected shaper rather than for all circuits.

You can also view the number of cells received, dropped, and sent on each side of a particular circuit on the selected shaper by entering the desired virtual circuit number.

- 6 To view virtual circuit statistics by port/group for the selected shaper, enter **p** from the Virtual Circuit Statistics by Shaper Detail screen. The screen that appears displays the same information as the Show Virtual Statistics by Port/Group Summary screen—except that it lists information by port/group only for circuits on the selected shaper rather than for all circuits.

You can also view the number of cells received, dropped, and sent from and to a particular port/group on the selected shaper by entering the desired port/group number.

Viewing Virtual Circuit Statistics by Buffer (Queue)

To display virtual circuit statistics by buffer, follow these steps:

- 1 From the Configuration Management menu, select *[2] Manage Card* to display the List Card menu.
- 2 Select *[2] CTX* to display the CTX menu.
- 3 From the CTX menu, select *[5] Show VC Statistics by Buffer* to display counts of cells sent and cells dropped for each buffer. The Virtual Circuit Statistics by Buffer summary screen is similar to the Virtual Circuit Statistics by Shaper summary screen, shown in Figure 150.
- 4 To view statistics for a single buffer, enter the desired buffer number. The Virtual Statistics by Buffer detail screen lists the number of cells received, dropped, and sent on the selected buffer. It is similar to the Virtual Circuit Statistics by Shaper detail screen shown earlier in Figure 151.
- 5 To view virtual circuit statistics by circuit for the selected buffer, enter **v** from the Virtual Circuit Statistics by Buffer Detail screen. The screen that appears displays the same information as the Show Virtual Statistics Summary screen shown earlier in Figure 149—except that it lists information only for circuits on the selected buffer rather than for all circuits.

You can also view the number of cells received, dropped, and sent on each side of a particular circuit on the selected buffer by entering the desired virtual circuit number.

- 6 To view virtual circuit statistics by port/group for the selected buffer, enter **p** from the Virtual Circuit Statistics by Buffer Detail screen. The screen that appears displays the same information as the Show Virtual Statistics by Port/Group Summary screen—except that it lists information by port/group only for circuits on the selected buffer rather than for all circuits.

You can also view the number of cells received, dropped, and sent from and to a particular port/group on the selected buffer by entering the desired port/group number.

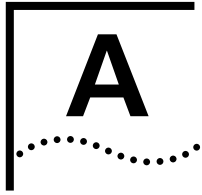

TECHNICAL SUPPORT

3Com provides easy access to technical support information through a variety of services. This appendix describes these services.

Information contained in this appendix is correct at time of publication. For the very latest, 3Com recommends that you access the 3Com Corporation World Wide Web site.

Online Technical Services

3Com offers worldwide product support 24 hours a day, 7 days a week, through the following online systems:

- World Wide Web site
- 3Com FTP site
- 3Com Bulletin Board Service (3Com BBS)
- 3ComFactsSM automated fax service

World Wide Web Site

Access the latest networking information on the 3Com Corporation World Wide Web site by entering the URL into your Internet browser:

<http://www.3com.com/>

This service provides access to online support information such as technical documentation and software library, as well as support options ranging from technical education to maintenance and professional services.

3Com FTP Site

Download drivers, patches, and software, across the Internet from the 3Com public FTP site. This service is available 24 hours a day, 7 days a week.

To connect to the 3Com FTP site, enter the following information into your FTP client:

- Hostname: **ftp.3com.com** (or **192.156.136.12**)
- Username: **anonymous**
- Password: **<your Internet e-mail address>**



A user name and password are not needed with Web browser software such as Netscape Navigator and Internet Explorer.

3Com Bulletin Board Service

The 3Com BBS contains patches, software, and drivers for 3Com products. This service is available through analog modem or digital modem (ISDN) 24 hours a day, 7 days a week.

Access by Analog Modem

To reach the service by modem, set your modem to 8 data bits, no parity, and 1 stop bit. Call the telephone number nearest you:

Country	Data Rate	Telephone Number	Country	Data Rate	Telephone Number
Australia	Up to 14,400 bps	61 2 9955 2073	Japan	Up to 14,400 bps	81 3 3345 7266
Brazil	Up to 14,400 bps	55 11 5181 9666	Mexico	Up to 28,800 bps	52 5 520 7835
France	Up to 14,400 bps	33 1 6986 6954	P.R. of China	Up to 14,400 bps	86 10 684 92351
Germany	Up to 28,800 bps	4989 62732 188	Taiwan, R.O.C.	Up to 14,400 bps	886 2 377 5840
Hong Kong	Up to 14,400 bps	852 2537 5601	U.K.	Up to 28,800 bps	44 1442 438278
Italy	Up to 14,400 bps	39 2 27300680	U.S.A.	Up to 28,800 bps	1 408 980 8204

Access by Digital Modem

ISDN users can dial in to the 3Com BBS using a digital modem for fast access up to 56 Kbps. To access the 3Com BBS using ISDN, use the following number:

1 408 654 2703

3ComFacts Automated Fax Service

The 3ComFacts automated fax service provides technical articles, diagrams, and troubleshooting instructions on 3Com products 24 hours a day, 7 days a week.

Call 3ComFacts using your Touch-Tone telephone:

1 408 727 7021

Support from Your Network Supplier

If additional assistance is required, contact your network supplier. Many suppliers are authorized 3Com service partners who are qualified to provide a variety of services, including network planning, installation, hardware maintenance, application training, and support services.

When you contact your network supplier for assistance, have the following information ready:

- Product model name, part number, and serial number
- A list of system hardware and software, including revision levels
- Diagnostic error messages
- Details about recent configuration changes, if applicable

If you are unable to contact your network supplier, see the following section on how to contact 3Com.

Support from 3Com

If you are unable to obtain assistance from the 3Com online technical resources or from your network supplier, 3Com offers technical telephone support services. To find out more about your support options, please call the 3Com technical telephone support phone number at the location nearest you.

When you contact 3Com for assistance, have the following information ready:

- Product model name, part number, and serial number
- A list of system hardware and software, including revision levels
- Diagnostic error messages
- Details about recent configuration changes, if applicable

Below is a list of worldwide technical telephone support numbers:

Country	Telephone Number	Country	Telephone Number
Asia Pacific Rim			
Australia	1 800 678 515	P.R. of China	10800 61 00137 or 021 6350 1590
Hong Kong	800 933 486	Singapore	800 6161 463
India	61 2 9937 5085	S. Korea	
Indonesia	001 800 61 009	From anywhere in S. Korea:	82 2 3455 6455
Japan	0031 61 6439	From Seoul:	00798 611 2230
Malaysia	1800 801 777	Taiwan, R.O.C.	0080 611 261
New Zealand	0800 446 398	Thailand	001 800 611 2000
Pakistan	61 2 9937 5085		
Philippines	1235 61 266 2602		
Europe			
From anywhere in Europe, call:	+31 (0)30 6029900 phone		
	+31 (0)30 6029999 fax		
From the following European countries, you may use the toll-free numbers:			
Austria	06 607468	Netherlands	0800 0227788
Belgium	0800 71429	Norway	800 11376
Denmark	800 17309	Poland	0800 3111206
Finland	0800 113153	Portugal	05 05313416
France	0800 917959	South Africa	0800 995014
Germany	0130 821502	Spain	900 983125
Hungary	00800 12813	Sweden	020 795482
Ireland	1 800 553117	Switzerland	0800 55 3072
Israel	177 3103794	U.K.	0800 966197
Italy	1678 79489		
Latin America			
Argentina	541 312 3266	Colombia	571 629 4847
Brazil	55 11 523 2725, ext. 422	Mexico	01 800 849 2273
North America			
	1 800 NET 3Com (1 800 638 3266)		

Returning Products for Repair

Before you send a product directly to 3Com for repair, you must first obtain a Return Materials Authorization (RMA) number. Products sent to 3Com without RMA numbers will be returned to the sender unopened, at the sender's expense.

To obtain an RMA number, call or fax:

Country	Telephone Number	Fax Number
Asia, Pacific Rim	65 543 6342	65 543 6348
Europe, South Africa, and Middle East	011 44 1442 435860	011 44 1442 435718
From the following European countries, you may call the toll-free numbers; select option 2 and then option 2:		
Austria	06 607468	
Belgium	0800 71429	
Denmark	800 17309	
Finland	0800 113153	
France	0800 917959	
Germany	0130 821502	
Hungary	00800 12813	
Ireland	1800553117	
Israel	177 3103794	
Italy	1678 79489	
Netherlands	0800 0227788	
Norway	800 11376	
Poland	00800 3111206	
Portugal	05 05313416	
South Africa	0800 995014	
Spain	900 983125	
Sweden	020 795482	
Switzerland	0800 55 3072	
U.K.	0800 966197	
Latin America	1 408 326 2927	1 408 764 6883
U.S.A. and Canada	1 800 876 3266, option 2	1 408 764 7120

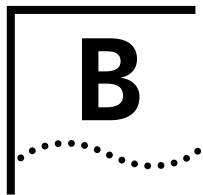

PATHBUILDER S330/S310 MODULE AND APPLICATION OVERVIEW

This chapter describes the operation and data flow for each of the SuperStack® II PathBuilder® S330 and S310 WAN access switch (PathBuilder S330/S310) modules and supported applications. It contains the following sections:

- Management CPU
- CTX Switch
- T1/E1 UNI Interface
- OC3/STM-1 Port
- DS3/E3 UNI Modules
- DS3/E3 UNI Modules
- Ethernet Interface
- CBR Module
- Voice Compression Module

Management CPU

The management CPU provides an intelligent user interface in addition to the other built-in interfaces available on the PathBuilder S330/S310. It also monitors and controls the activity on the shelf. These functions include:

- Providing a user interface through a VT100 terminal or Ethernet (Telnet).
- Programming configurations.
- Generating and filtering alarms and transmitting them to the NMS.
- Gathering performance-monitoring data.
- Checking and assigning an appropriate clock source.
- Communicating with other nodes via the management VC channel.

CTX Switch

The CTX switch interfaces to all ATM busses in the system. It handles address translation and switching among seven ATM ports. Up to four ports come from the T1/E1 UNIs. The other three ports come from the onboard OC3/STM-1, the SAR, and expansion slots 7, 8, and/or 9 (the optional CBR module, Voice Compression module, and DS3/E3 UNI module).

Address translation is done via two lookups. The first lookup is a VP lookup (all 8 bits included). If a VP circuit is set up, then a VP translation is done; otherwise, a second lookup consisting of 2 VPI bits and 8 VCI bits, is done. For VC connections, any four VPs in the range 0-255 are allowed. Once the VC is found, the CTX performs the address translation.

If a cell carries data, then the switch tries to place it in the proper output FIFO (First-In, First Out) order. If the queue is congested and early packet discard is

enabled, an early packet discard operation is performed to check if the cell needs to be discarded. Counters for cells received and cells dropped are also updated, depending on the operation.

CTX Output Queues and Memory Partition

The CTX is an output buffered switch, with a bus capacity of 400Mbits total. It can store 64K cells. The CTX terminates three Utopia buses, each capable of terminating an OC3/STM-1 payload.

- The first bus carries the OC3/STM-1 interface on the motherboard.
- The second bus is shared between the SAR and expansion slot 7; both are treated as separate ports in the switch.
- The third bus is used by the four T1/E1 UNI ports; this bus can handle up to four separate ports in the switch.

The output buffer is statically divided on power up into 256 cell blocks. Any number of blocks can be allocated to any queue. The software sets up a reasonable default configuration, as listed on the CTX Buffers menu, shown in Figure 152.

To modify the CTX Buffers, follow these steps:

- 1 Open the CTX Buffers menu.
 - a From the Configuration Management menu, select [1] *Manage Card*.
 - b From the List Card menu, select [2] *CTX*.
 - c From the CTX menu, select [2] *Manage Buffers*.
- 2 Modify the CTX buffer configuration. Modify the default.

Figure 152 CTX Buffers Menu Displaying Default Memory Allocation

Slot	Interface	Queue	Buffer Cells	Cong On %	Cong Off %
1)	3	IMA Grp 1	0 (high) 768	75	50
2)	3	IMA Grp 1	1 768	75	50
3)	3	IMA Grp 1	2 768	75	50
4)	3	IMA Grp 1	3 19200	75	50
5)	3	IMA Grp 2	0 (high) 768	75	50
6)	3	IMA Grp 2	1 768	75	50
7)	3	IMA Grp 3	0 (high) 768	75	50
8)	3	IMA Grp 3	1 768	75	50
9)	3	IMA Grp 4	0 (high) 768	75	50
10)	3	IMA Grp 4	1 768	75	50
11)	4	OC3	0 (high) 768	75	50
12)	4	OC3	1 768	75	50
13)	4	OC3	2 768	75	50
14)	4	OC3	3 19200	75	50
15)	(SAR ports)	0 (high) 768	75	50	
16)	(SAR ports)	1 6400	75	50	
17)	7 (EXP7)	0 (high) 768	75	50	
18)	7 (EXP7)	1 768	75	50	
19)	8 (EXP8)	0 (high) 768	75	50	
20)	8 (EXP8)	1 768	75	50	

Enter Queue# (1..20) or 21 for previous page [21]:

If you are not using a certain port and need to reallocate the buffers or do not like the default configuration, you can define a new configuration. See “Configuring CTX Buffers” in Chapter 4, for details.



The default memory configuration uses all available memory. In order to reallocate memory to a given queue, you must first deallocate it from one of the other queues.

Since the CTX is output-buffered, and if the WAN trunk has the lowest speed (for nxT1/E1), the WAN trunk should take up most of the buffer.

CBR traffic (voice and video) requires the least latency during transmission, while VBR traffic (email and FTP) is more tolerable to delays but more sensitive to errors. The PathBuilder S330/S310 platform handles these traffic patterns with multiple levels of priorities. Each switch port, except the first T1/E1 UNI port, has two queues: one for high and one for low. The first T1/E1 UNI port or IMA group has four queues: one for high (0), one for medium (1), and two for low (2,3) with multiple traffic shapers.

To get a practical feel for the queue size configuration, consider an example in which the PathBuilder S330 is configured on the trunk side with a single group of 4 x T1/E1. The other three groups on the trunk are not used. In this case, all the cells coming from the high-speed OC3/STM-1 are going to end up in the T1/E1 buffers.

You could partition the memory on the trunk side as follows (with one block equalling 256 cells and the minimum queue size being 3 blocks):

- The T1/E1 buffer could be configured to 48K (192 blocks) cells large.
- The high queue could be 768 cells or 3 blocks (normally small),
- The medium queue could be up to 16 blocks large, depending on the number of connections and the bursts tolerated.

The remaining 173 blocks could be divided evenly among the two low queues.

You could partition the remaining 16K cells (64 blocks) as follows:

- 3 blocks for expansion slot 7 high
- 3 blocks for expansion slot 7 low
- 3 blocks for OC3/STM-1 2 high
- 26 blocks for OC3/STM-1 low
- 3 blocks for SAR high
- 26 blocks for SAR low

This is just an example; normally the lower the speed, the more buffering is needed. When the T1/E1 IMA is configured for more than one group, then the first group gets four queues and the rest get two queues. In most cases, if the groups have the same speed, then the cells reserved for the trunk can be divided equally.

Setting up a Virtual Circuit

To configure a circuit in the PathBuilder S330/S310, you must set up a virtual circuit between any two ports through the CTX. See "Configuring Virtual Circuits" in Chapter 4, for details about setting up virtual circuits.

VPI and VCI Ranges

As explained earlier in this chapter, address translation is performed in the CTX. For VP connections, the full 8 bits of the VPI is looked up, so up to 256 VP connections are supported per port. For VC connections, only two LSB VPI bits and 8 LSB VCI bits are considered. So, for VC connections, VPs 0 through 3 and VCs 1 through 255 are the only ones supported.

Early and Partial Packet Discard

Early packet discard (EPD) and partial packet discard (PPD) functions are provided on the CTX for every connection. EPD and PPD are enabled per VC for those VCs carrying AAL5 traffic.

For EPD, every output queue contains two thresholds that you can set: congestion ON and congestion OFF. You set these thresholds by percentage. See “Setting Congestion Thresholds” in Chapter 4, for details about setting congestion thresholds. Partial packet discard works when the queue is actually full and a cell is dropped for a particular connection. When this happens, the rest of the cells for that connection are discarded until the end of packet is reached.

T1/E1 UNI Interface

The four T1/E1 UNI interfaces allow you to connect legacy, voice, video, and data traffic to your branch offices, using either single T1s/E1s or nxT1/nxE1 IMA bundles. The IMA bundles connect up to four lines from a single office site.



The PathBuilder S310 has only a single T1/E1 interface.

On the T1/E1 receive side, the data flow is as follows:

- A line interface unit recovers the digital data and performs the T1/E1 framing on it with DSX and CSU capability. The integral CSU eliminates the need for an external CSU.
- The data flows through a framer to get the ATM cells.
- The output of the framer interfaces to the IMA circuitry that stores the data into memory and synchronizes the cells back. All four T1's/E1s go into the IMA buffers where they can be treated as one group or as four separate groups (four individual T1's/E1s).
- After the cells are synchronized, the IMA circuitry tags them with a group number and passes them to the CTX. At the CTX interface, the cells will look like they are coming from different groups.

On the T1/E1 transmit side, the data flow is as follows:

- Cells received from the CTX toward the T1/E1 groups are stored in the corresponding buffers, as described under “CTX Output Queues and Memory Partition” earlier in this chapter. Group 1 consists of 4 buffers; the other three groups have two buffers each.
- The cells are picked up from the queues in order of priority, under the shaper control, and delivered to the IMA logic.
- The IMA logic spreads the cells in a particular group across the physical lines and adds the IMA overhead functions.

- The cells are passed to a line HEC framer to synchronize to the line speed.
- The T1/E1 chip adds the T1/E1 overhead and converts the digital data into a bipolar format suitable for transmission.

An 8 KHz clock is extracted from the T1/E1 clock (on all T1's/E1s) and is used for system synchronization. The system uses this clock or other clocks to generate a stable 8 KHz clock for all other modules and interfaces.

OC3/STM-1 Port



The OC3/STM-1 port supports either a multi-mode fiber interface—used mostly for local workgroup switch connection—or a single-mode fiber interface—used for intermediate range operation (up to 15 kilometers).

The PathBuilder S310 does not include an OC3/STM-1 port.

On the OC3/STM-1 receive side, the data flow is as follows:

- A fiber interface module converts the light to electrical data.
- The data is fed to a chip where the clock is recovered. The PHY chip also provides all the line functions and cell framing.
- The chip interfaces directly to the CTX, which performs address translation and output buffering.
- The data is placed in the corresponding output buffer.

On the OC3/STM-1 transmit side, the data flow is as follows:

- Cells received from the CTX are passed directly to the transmitter. Four buffers are supported for the OC3/STM-1.
- The output of the chip feeds into the fiber interface module.

An 8 KHz clock is extracted from the OC3/STM-1 clock, and the system uses the OC3/STM-1 clock or other line clocks to generate a stable 8 KHz clock to be used for system synchronization.

DS3/E3 UNI Modules

The optional DS3 module is compatible with AT&T Publication 54014 specifications, uses the unchannelized format, and is compliant to M23 or the C-bit parity ANSI-107a, 1991 specifications. It performs the following key functions:

- Provides line interface functions and terminates the FEAC and MDL for the C-bit format
- Performs ATM to physical layer mapping and adds PLCP according to UNI 3.0
- Performs peak traffic shaping on the transmit (14 bulk shapers)

The optional E3 UNI module is typically used for terminating/accessing public or private WAN services. However, depending on your local applications, you can also use this module in the port slot for taking local traffic across the WAN.

The E3 UNI module performs the following key functions:

- Performs ATM to physical layer mapping and adds PLCP according to UNI 3.0
- Performs peak traffic shaping on the transmit (14 bulk shapers)

Serial Interface

The serial interface is designed to interconnect frame-based devices/networks and cell-based ATM devices/networks. The PathBuilder S330/S310 provides a single serial interface that can be configured as DTE or DCE and, with different cable adapters, can support V.35/RS-449/RS-530/X.21 interface to routers.

The PathBuilder S330/S310 can perform cell-to-frame as well as frame-to-cell conversion. On the serial interface receive side, frames received from the HDLC serial interfaces are segmented to cells by the SAR and passed to the CTX chip where they can be switched. On the serial interface transmit side, cells received from the ATM interfaces are reassembled into frames and passed to the HDLC serial interfaces.

The PathBuilder S330/S310 uses a RISC processor to perform the lookup and interworking functions between frame and ATM services. It also performs the LMI functions and collects alarms and statistics.

The PathBuilder S330/S310 provides for frame relay service and network interworking (FRF 5 and 8), as well as ATM DXI and transparent HDLC operation. You can use it for interworking between the ATM network and a variety of different frame-based networks or devices such as Frame Relay and ATM DXI.

The interface can be clocked up to 6.2Mbps, and it supports the following modes of operation:

Internal timing—DCE provides the clock for a router.

External timing—DTE receives a clock from a DCE device such as a DSU (digital service unit).

The mode of operation is selected automatically (by autosensing), based on the type of cable connected to the unit—DCE or DTE.

Serial Interface Frame Protocol Modes

The PathBuilder S330/S310 supports three modes of Frame-to-Cell transit services:

ATM DXI Mode 1A—Supported by certain routers.

HDLC/SDLC—Used mainly for transparent point-to-point operation.

Frame Relay Forum Specification 5 and 8; modes 1 and 2—Used to terminate a frame relay router.

Each service is designed to support a different type of user application; however, all the services share the same ATM backbone characteristics. The serial port modules are mapped over ATM Permanent Virtual Circuits (PVCs).

When connecting the PathBuilder S330/S310 to an ATM network, verify that the PVC mapping for in and out ports is defined for proper operation. (See Figure 153.)

Figure 153 PathBuilder S330/S310 to ATM PVC

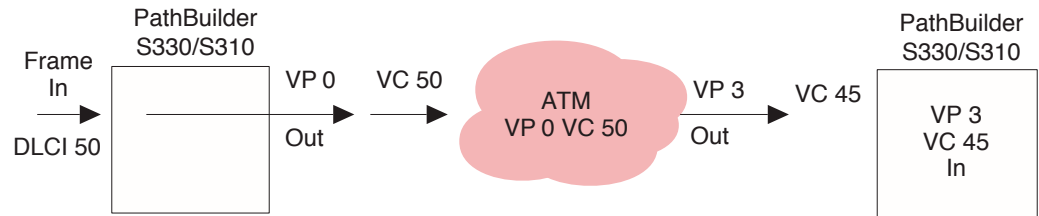

It is also important to select the proper traffic contract from the ATM switch/service provider. This card should utilize a VBR or CBR circuit set at the speed of the connected port. (See Figure 154.)

Figure 154 PathBuilder S330/S310 Traffic Contract

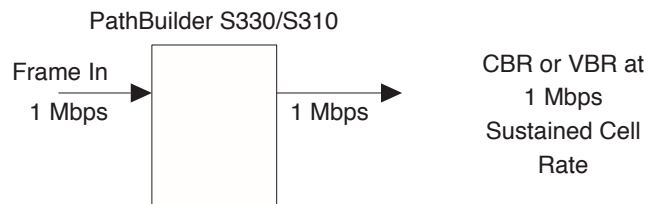

VBR service will work; however the synchronous path will be subjected to possible discards and delay.

The following subsections describe the supported frame protocol modes in greater detail.

ATM DXI Mode

ATM DXI mode is used to interconnect a DTE to a DCE. The DTE is typically a legacy interworking device with limited ATM capability. Through ATM DXI, the DCE allows the DTE to participate in an ATM network. Figure 155 illustrates a PathBuilder S330/S310 in the ATM DXI network.

Figure 155 DXI Network Connection

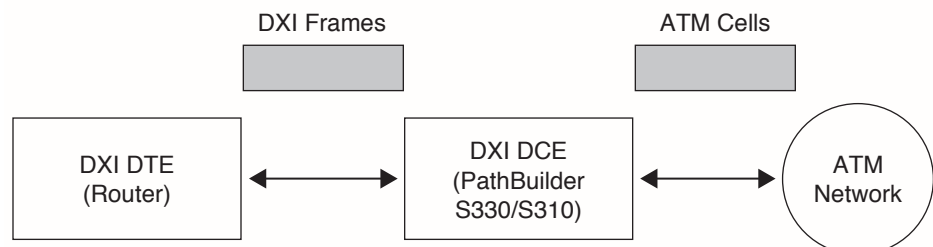

DXI protocol defines an open interface between the router and the Data Service Unit. The Data Service Unit off-loads cell encapsulation services from the Brouter. This will allow your current brouter to support ATM, simply by supporting V.35 and High-level Data Link Control (HDLC).

The DXI protocol itself is based on HDLC and provides the mapping within the HDLC frame to place the router data on an appropriate VC. (See Figure 156.)

Figure 156 DXI Protocol Enabling Transmission Between ATM Network and DXI Device

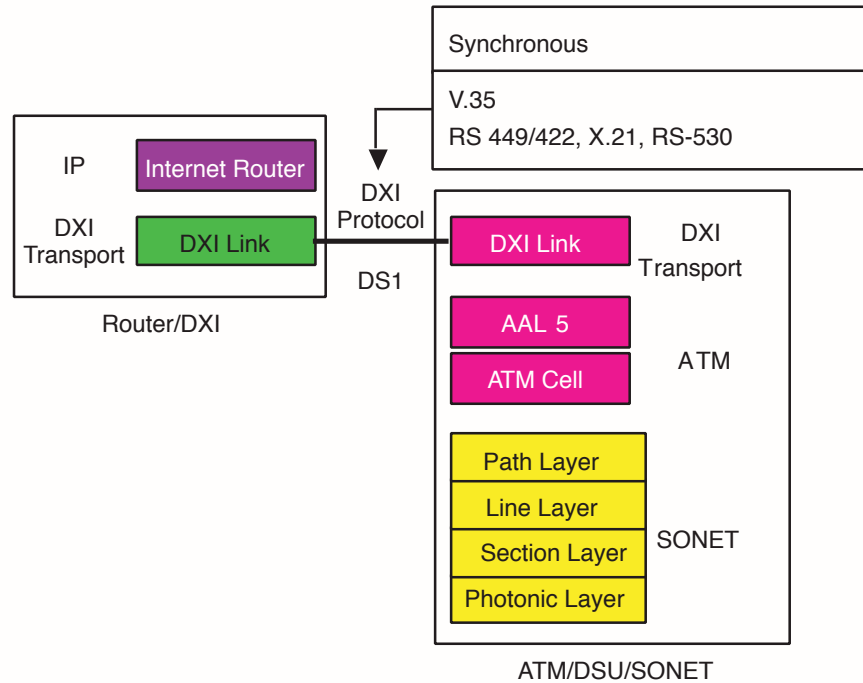

The ATM DXI Specification defines 3 different modes (1a, 1b, and 2) of connections. This software release supports Mode 1a, which includes the following features:

- Up to 1023 virtual connections
- Uses AAL5
- Maximum DTE SDU size: 9232 bytes
- Uses 16-bit FCS

Through ATM DXI, the DCE allows the DTE to participate in an ATM network. (See Figure 157.)

Figure 157 DCE Allows DTE to Participate in ATM Network through ATM DXI

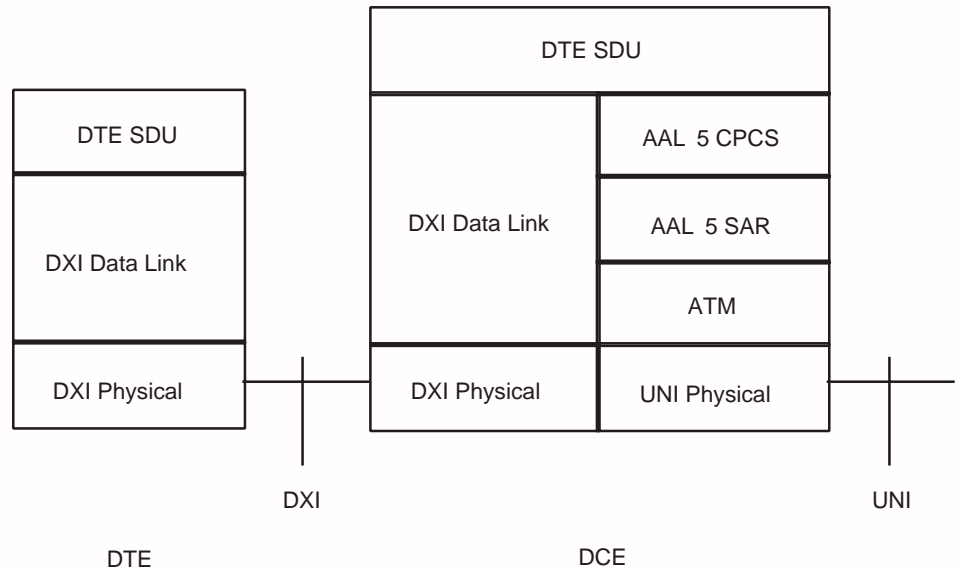

DXI Mode 1A is designed to allow legacy routers to utilize frame-based transmission to transmit an ATM network to the DXI Mode 1A device (PathBuilder S330/S310 serial interface), which then will perform SAR and AAL5 mapping to an ATM PVC. It provides simple and efficient encapsulation of your service data unit and supports AAL5 transit encapsulation. (See Figure 158.)

Figure 158 DXI Format Mode 1A

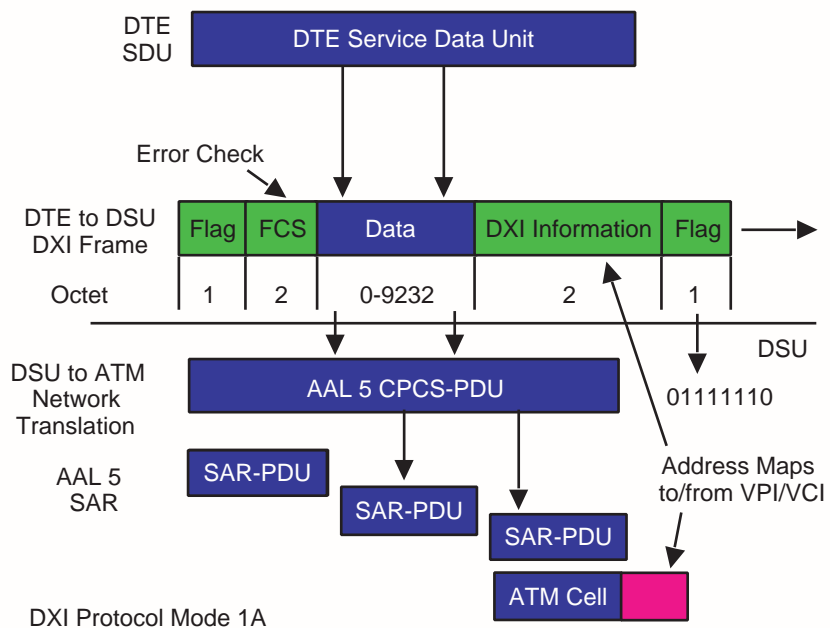

DXI protocol frame is an HDLC LLC1 frame similar to PPP protocol. Mode 1A supports an AAL5 transit encapsulation. In terms of the Brouter, it is easier to implement DXI protocol, since it only requires the Brouter to encapsulate the SDU. DXI protocol supports up to 1023 connections and up to 9232 octets of payload. (See Figure 158 on the previous page.)

Figure 159 shows the applications for DXI.

Figure 159 DXI Applications

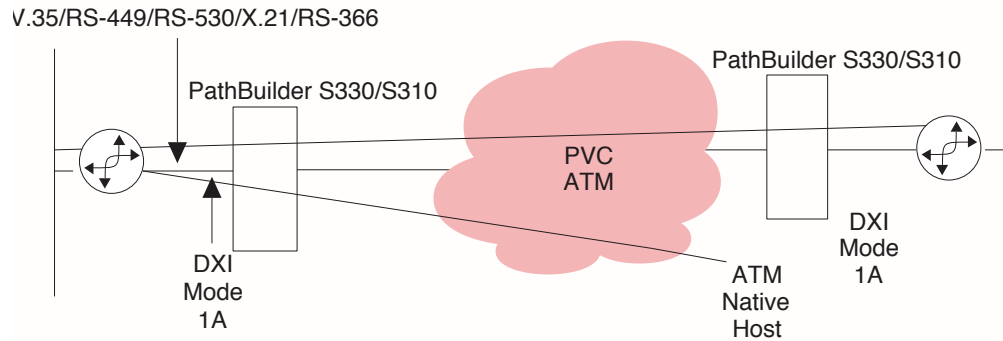

When the PathBuilder S330/S310 receives a DXI Frame from the DXI DTE or an ATM CPCS protocol data unit (PDU) from the ATM network, it translates from frames into ATM CPCS PDUs or from ATM CPCS PDUs into frames by doing the following:

- Mapping the DFA in the DXI frame to the VPI/VCI in the ATM cell header
- Mapping the CLP in the DXI frame to the CLP in the ATM cell header
- Mapping the CN in the DXI Frame to the PTI in the ATM cell header

Mapping the DFA in the DXI Frame to the VPI/VCI in the ATM cell header

In the DXI frame header, the DFA occupies 6 bits (bit 3 to bit 8) in the first octet and 4 bits (bit 6 to bit 8) in the second octet. The ATM DXI Specification defines a method for mapping between DFA and VPI/VCI. You can configure the PathBuilder S330/S310 by assigning the mapping values in certain way. See "Configuring Virtual Circuits" in Chapter 4, for details.

Mapping the CLP in the DXI frame to the CLP in the ATM cell header

When data is moved from DXI to ATM, the CLP bit in the DXI header is copied into the CLP field in the ATM cell header without change. When data is moved in the reverse direction, the CLP bit in the DXI header is always set 0, no matter what value it is in the ATM cell header.

Mapping the CN in the DXI Frame to the PTI in the ATM cell header

When data is moved from DXI to ATM, the CN bit is always set to 0 by the DTE. When data is moved in the reverse direction, the CN bit is set to 1 if PTI is 01x in the last ATM cell of the AAL5 CPCS PDU; otherwise, it is set to 0.

HDLC/SDLC Mode

Transparent HDLC mode is used for point-to-point HDLC connections across the ATM network. No service-based encapsulation other than AAL5 is needed. All packets are terminated and SAR'd to a single VP/VC in the ATM network.

Transparent mode functionality is best implemented with a PRBS type of pattern included in a sequence of frames. The TTC Firebird V.35 frame relay interface provides that simple capability.

When using transparent HDLC mode, you set the following parameters:

- Minimum number of flags between HDLC frames
- CRC type

The PathBuilder S330/S310 will SAR AAL5 and map HDLC/SDLC frames onto an ATM VCC. You could use the HDLC service for router to router and X.25 to X.25 links. You could use the SDLC service for IBM FID2 3270 SNA Peripheral or IBM FID4 372X SNA Backbone.

Figure 160 shows HDLC/SDLC applications.



You should disable NRZI on the FEP (i.e., IBM 3745). NRZI is commonly used when the FEP is connected to DSUs over a non-digital line. The PathBuilder S330 does not require NRZI to be enabled.

Figure 160 HDLC/SDLC Applications

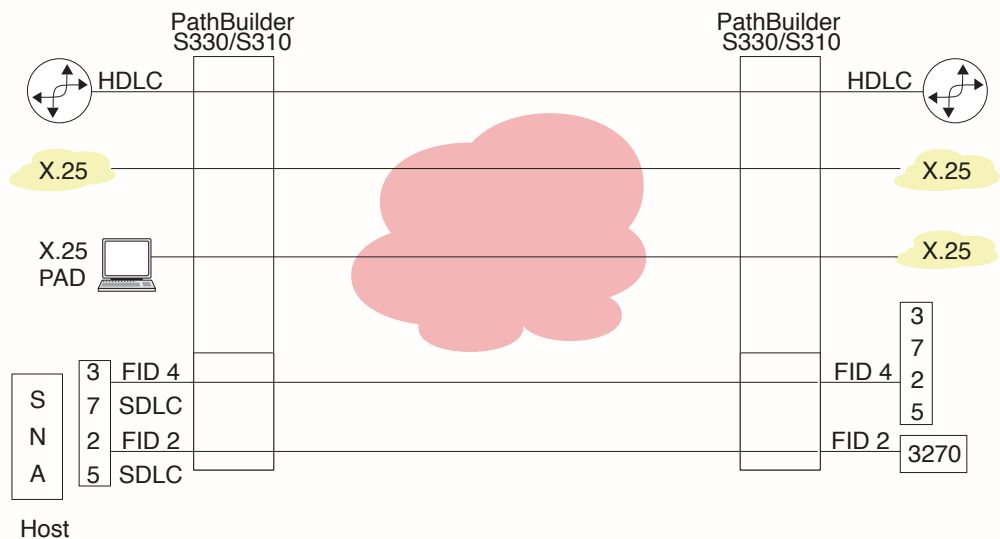

Frame Relay Mode

Frame relay mode is used to terminate a frame relay router, across the ATM network, for example. This protocol mode converts the frame relay DLCI to a VP/VC ATM connection.

A PathBuilder S330/S310 provides two interworking features to interconnect a Frame relay network with an ATM network:

- Service Interworking
- Network Interworking

These interworking features are described in FRF.8 and FRF.5 respectively. The major difference between these two features is that there is no FR-SSCS function required for Service Interworking.

The following sections describe the details of these two interworking functions as well as the features provided by the PathBuilder S330/S310.

Service Interworking Function

Figure 161 shows a PathBuilder S330/S310 providing Service Interworking function between Frame Relay and ATM services. In this setup, a Frame Relay DTE communicates with an ATM DTE, regardless of the fact that there is a different type of DTE at each end of the connection.

Figure 161 Frame Relay/ATM Service Interworking Connection (FRF.8)

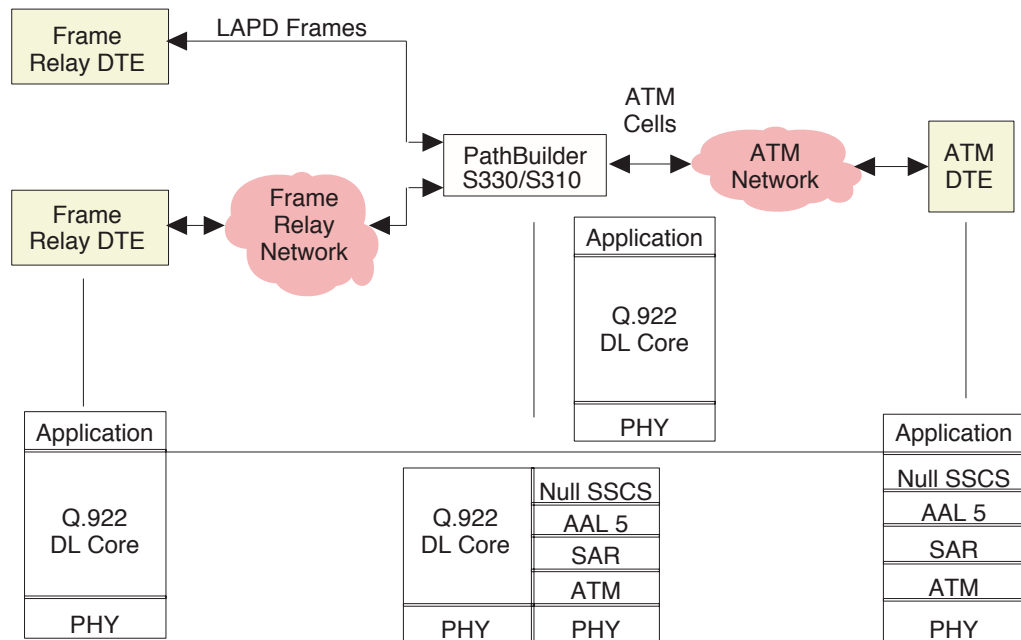

The interworking scheme shown in Figure 161 works as follows:

- The application on the frame DTE passes its data through Q.922 core service with the assumption that there is an end-to-end pipe to carry its data from its end to the other DTE at the far end. The Q.922 core only sees a point-to-point link to the next connection point; it has no knowledge about the type of network behind the current link.
- On the other end, the application residing in ATM DTE passes its data through a NULL SSCS that sits on top of AAL5. What this ATM DTE sees is the ATM network to which it is connected.

- The PathBuilder S330/S310 sitting in the middle performs all the required translation and management functions between these two networks, implementing the stacks as indicated in Figure 162 and performing the following key functions:
 - Translating from Q.922 Frame to ATM AAL5 PDU and from ATM AAL5 PDU to Q.922
 - Performing Frame PVC management
 - Managing traffic
 - Handling congestion

Network Interworking Function

Figure 162 shows a PathBuilder S330/S310 providing Network Interworking function between Frame Relay and ATM services.

Figure 162 Frame Relay/ATM Network Interworking Connection (FRF.5)

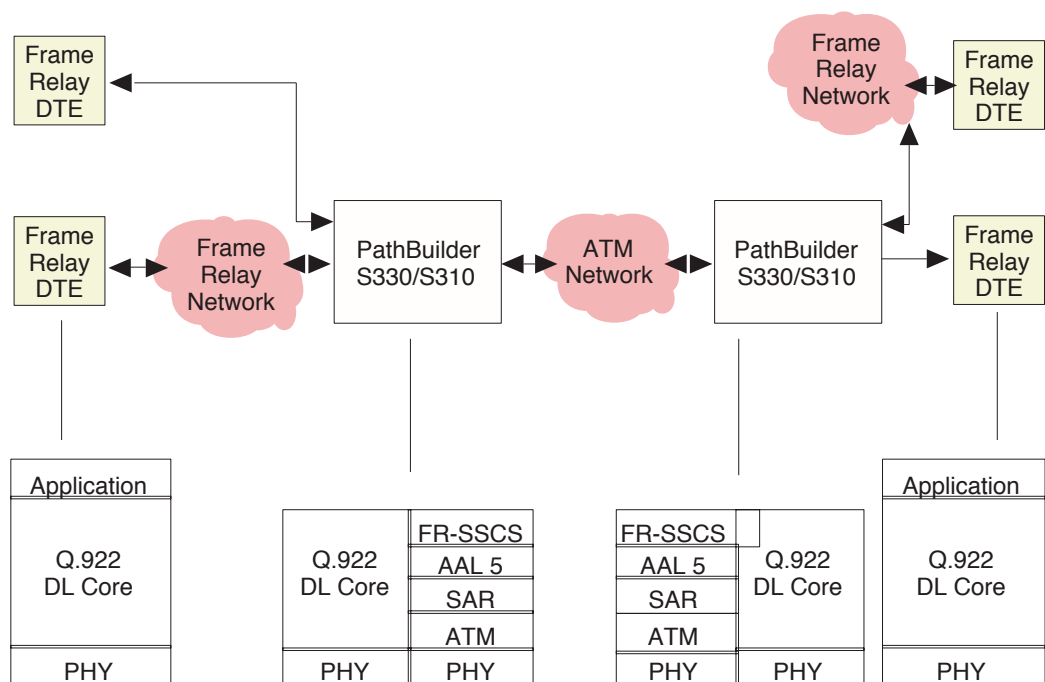

In the interworking scheme shown in Figure 162, a Frame Relay DTE communicates with the other Frame Relay DTEs through an ATM network. Note that FR-SSCS is used in this configuration.

This interworking scheme works as follows:

- The Frame Relay DTE at either end works exactly the same way as the Frame Relay DTE in the Service Interworking configuration: it passes its data through Q.922 core service, assuming that there is an end-to-end pipe to carry its data from its end to the other DTE at the far end.
- On the other end, the application resides in a Frame DTE instead of an ATM DTE.

- The PathBuilder S330/S310 performs all the required translation and management functions between these two networks, implementing the stacks as indicated in Figure 162 and performing the following key functions:
 - Translating from Q.922 Frame to FR-SSCS/ATM AAL5 PDU and from FR-SSCS/ATM AAL5 PDU to Q.922 Frame
 - Supporting 2-octet—not 3-octet or 4-octet—FR header (10-bit DLCI)
 - Allowing you to configure DLCI to VPI/VCI mapping
 - Providing one-to-one mapping: maps one FR-SSCS DLCI (default FR-SSCS DLCI (1022) or 16-991) for one FR DLCI to one ATM VPI/VCI. (The FR-SSCS DLCI(s) for the two end systems should be configured to be the same.)
 - Managing traffic
 - Handling congestion

Ethernet Interface

The PathBuilder S330/S310 Ethernet LAN modules provide multiple connections to Ethernet segments over ATM WAN.

When the Ethernet interface receives data from the LAN, any packets appearing on the 10BASE-T ports are checked for packet integrity and stored in the shared memory area. The system then performs a bridge operation to determine if the packet will be sent on to any other interface. See “Bridge Operation” below, for details.

- If the packet is to go on the HDLC port, it is bridged directly after being encapsulated properly for Frame Relay.
- If the packet is to go on an ATM interface, the bridge determines the VCI connection for the packet destination. The packet is then encapsulated according to RFC 1483, and the descriptor is handed off to the SAR, together with the associated ATM header descriptor. The SAR appends the AAL5 convergence sublayer to the packets and queues them according to the shaper you specify for that connection. The packet is then segmented according to the rate of the traffic descriptor, and the cells are sent to the CTX where ATM switching and queueing is performed.

The SAR contains 15 traffic shapers, each of which can be programmed for sustained cell rate of transmission (SCR), peak cell rate (PCR), and maximum burst size (MBS).

The traffic shapers work as follows:

- The packet is segmented using a dual leaky buffer algorithm, whereby the cells are transmitted from each connection in the shaper at an average rate until the bucket of token fills up (a token is given to the connection at an average rate if it has no cells to transmit at that moment).
- The shaper then turns the burst mode on and transmits at the peak rate for a burst length. Note that the shaper serves every connection independently.
- Cells received from the ATM WAN are switched via the CTX chip to the SAR queues. You can enable shaping on the SAR queues to slow down the incoming traffic on the SAR.

- The SAR will then assemble the cells belonging to the connections specified for it.
- When the cells are assembled, the CPU is given confirmation, and the bridge function of the CPU examines the packet header, removes the encapsulation, and—after learning the address and updating the bridge table—forwards the packet to the proper destination.
- The pointer of the packet to be forwarded is placed in the transmit queue of the Ethernet port.

Bridge Operation

The PathBuilder S330/S310 supports ATM permanent virtual circuits (PVCs) for access to the ATM network. All the PVC's configured for a port will form a virtual Bridged Ethernet network to all other ports at the other end of the PVC.

The bridge operation is equivalent to a multiport bridge. It works as follows:

- The bridge learns and builds forwarding tables for every PVC that is tied to the Ethernet port.
- When a packet is received on the port or any PVC tied to that port, the Source MAC address is learned and kept in the forwarding table until the aging timer expires. You can use the Bridge Configuration menu to add static forwarding addresses that the bridge will not delete after the aging timer expires. See "Configuring the Bridge" in Chapter 4, for details.
- When the packet arrives, the bridge looks up the destination MAC address to determine the destination of the packet from the forwarding tables. If a destination is found, the packet is forwarded to the correct destination. If a destination is not found, the bridge broadcasts or floods the packet on all PVC's that are tied to the Ethernet port. Flooding is performed by forwarding the packet on all destinations tied to the port.

The PathBuilder S330/S310 performs LLC-based multiplexing. Ethernet frames are bridged as per RFC 1483. Frames with NLPID of 0x00 are discarded as being invalid frames. The PathBuilder S330/S310 does not support frames bigger than Ethernet maximum frame size (1518) or IEEE802.3 frame size (1492) bytes (+ framing bytes) coming off the ATM network.

The following subsections provide further detail about bridging operations.

Filtering

The first bridging operation determines if the packet is to be processed and transmitted across the bridge or filtered out based on the list of protocols and addresses input as part of the PathBuilder S330/S310 configuration. Filtering gives you control over who communicates with whom in the network. The CPU reads the header of each packet to determine the protocol, source address, and destination address and then looks in the list to see if the packet should be passed through the bridge. If it is to be filtered out, it is cleared from memory.

Spanning Tree Spanning Tree (IEEE 802.1d) is a technique that detects loops in a network and logically blocks the redundant paths, ensuring that only one route exists between any two LANs. It eliminates the duplication of packets and provides fault tolerance for resilient networks.

As the Spanning Tree is being constructed, bridges exchange information, which is transmitted in packets called Configuration Bridge Protocol Data Units (C-BPDUs). During this process, the Spanning Tree Algorithm and Protocol (STAP) module elects a root bridge in order to establish a stable spanning tree topology. The root bridge determines the spanning tree topology and controls which bridges block packets and which forward packets.

Once the topology is stable, all STAP bridges listen for special “Hello” C-BPDUs transmitted from the root bridge at regular intervals (usually every two seconds). If a STAP bridge timer expires before receiving a “Hello” C-BPDU, it assumes that the root bridge, or a link between itself and the root bridge, has gone down. It then initiates a reconfiguration of the Spanning Tree.

When a port goes down (for instance, when an ATM VC is deleted), the port card notifies the STAP module of such a change. The STAP module then reinitiates the process of electing a root bridge, and the Spanning Tree calculation process begins all over again.

Spanning Tree Operation

The Spanning Tree operates as follows:



For more detailed information about how the Spanning Tree operates, see IEEE802.1d.

- An STAP module runs as a task on the management card. This task is responsible for maintaining all data structures for Spanning Tree operation for all ports and for sending/receiving Spanning Tree configuration packets.
- Spanning Tree Bridge configuration Protocol Data Units (BPDUs) are received at Ethernet port cards (on Ethernet and ATM ports) and are sent to the STAP module on the management card.
- The management card STAP module examines the packet, reads the MAC address of the sender, and analyzes the costs reported by the sender.
- When state of a port changes, the STAP module notifies the port card of the change.
- When a port card receives change information for a port, it updates the operational state of the port so as to change the bridging operation on the port. For instance, if a port in a forwarding state (normal operation mode of receiving and forwarding packets) is discovered to be forming a loop, it can be put in a blocking state. Once the port goes in the blocking state, the port card will stop receiving frames on the port.

Spanning Tree Instances

The Spanning Tree logic supports a maximum of 255 physical and virtual ports, thereby allowing a maximum of 254 ATM VCs. (One Ethernet port is required be set aside for other purposes.)

For the purpose of Spanning Tree operation, each set of one Ethernet port and its associated ATM VCs is treated as one bridge entity. The STAP module runs a separate instance for each bridge entity. Since the PathBuilder S600 shelf can be filled with a maximum of three Ethernet cards, each with two Ethernet ports, a maximum of six instances of STAP can be running on the management card.

Each STAP instance runs independently of the other STAP instances and processes configuration packets as if they came from a different physical bridge device. This approach helps segregate Ethernet ports completely for the purposes of bridging and Spanning Tree and enables the PathBuilder S600 to operate as six separate bridges.

VC-VC Bridging operation The Ethernet module supports full-mesh bridging between its Ethernet port and all of its associated VCs. This bridging must be bidirectional and should be conditional upon the operational status of the Spanning Tree. If Spanning Tree operation is disabled, VC-VC bridging is not necessary since the PathBuilder S600 is not expected to forward traffic coming from the ATM network.

For instructions on enabling and disabling the Spanning Tree, see “Enabling and Disabling the Spanning Tree” in Chapter 4.

Addressing

The next bridging operation is to determine if a packet is addressed to another unit on the LAN (in which case it can be rejected) or if it is addressed to a unit across the bridge.

Each Ethernet packet includes a source address and a destination address in its header. These are MAC addresses which are unique physical addresses assigned to every Ethernet interface on every Ethernet LAN. Packet transmission from one unit to another on the same LAN is easily accomplished. However, packet transmission between units on different LANs requires a higher-level addressing scheme.

ATM networks are organized into virtual circuits or logical duplex paths between two ATM unit ports as shown in Figure 163.

Each transmission direction in a virtual circuit is referred to as a virtual channel. Virtual channels are then grouped into virtual paths between two ports. The channels and paths are assigned numbers; VPIs (Virtual Path Indicators) and VCIs (Virtual Channel Indicators). Each ATM cell (a fixed-length unit of data over ATM) is assigned to a virtual circuit by including the circuit's VPI/VCI in the cell's header. These are then used to steer the cell through an ATM unit and the ATM network.

Figure 163 Virtual Circuit Scheme

Figure 164 illustrates this on a network using PathBuilder S330s. Suppose workstation 1 on LAN AA wants to send data to workstation 2 on LAN BB. It transmits Ethernet packets which include its MAC address and that of workstation 2. PathBuilder S330 A groups the packets into cells and, since it does not know where workstation 2 is, broadcasts the cells on all VPI/VCI. PathBuilder S330 B learns that workstation 1 transmits to its T1/E1 UNI port over VPI/VCI 1/33 and VPI/VCI 2/35. This information is then stored in forwarding tables in PathBuilder S330 B.

When workstation 2 responds, it includes its MAC address and that of workstation 1 in the packets. PathBuilder S330 B looks in the appropriate forwarding table and finds that it can reach workstation 1 on VPI/VCI 2/5. When the first response cell on 2/35 is formatted back into packets at PathBuilder S330 A, then PathBuilder S330 B learns how to reach workstation 2 without broadcasting.

Figure 164 Virtual Circuits in a Simple Network

The aggregate of VPIs/VCIs assigned to the Ethernet connection of the PathBuilder S330/S310 is referred to as a bridge. Since the PathBuilder S330/S310 reads and stores MAC addresses and associated VPIs/VCIs as described above, the bridge is called a learning bridge. Each learning bridge of the PathBuilder S330/S310 has a separate forwarding table containing the MAC address to VPI/VCI associations.

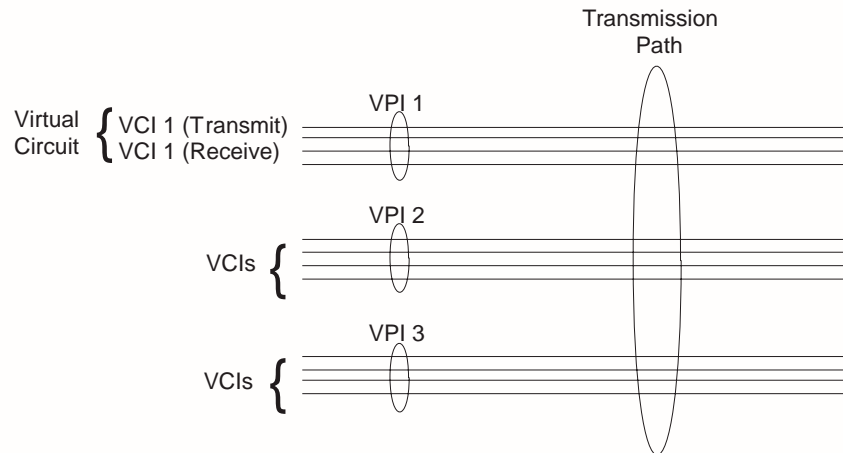
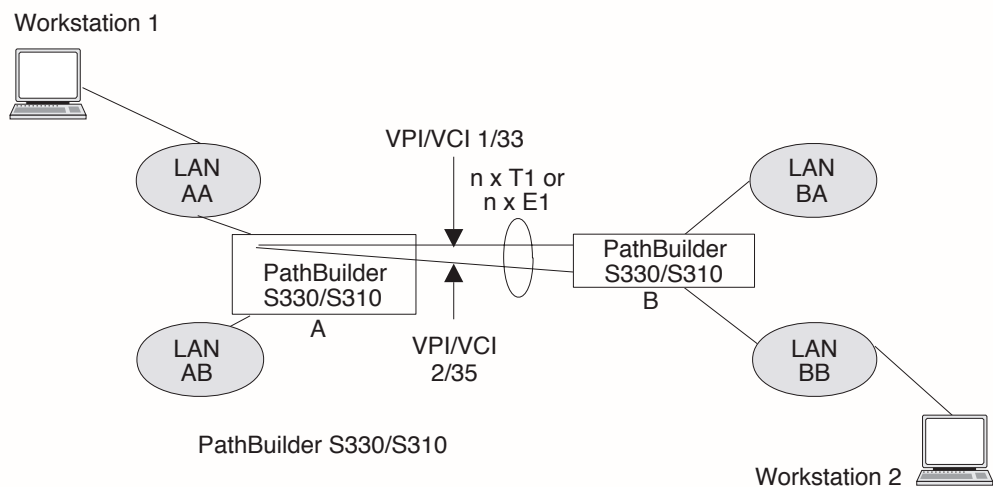
When a learned entry is stored in a forwarding table, it is time tagged. An aging timer in the PathBuilder S330/S310, which you set, purges entries from the forwarding tables after they have been in the tables for the aged time. The bridges must then relearn purged addresses. This controls the size of the forwarding tables, particularly in large networks.

In the PathBuilder S330/S310, each bridge also has a static table associated with it. You can enter MAC addresses and corresponding VPIs/VCIs into the static table that will not be affected by the aging timer. These entries might be for LAN units that are relatively permanent and are accessed through the ATM network frequently, such as servers.

In the example shown in Figure 164, there is only one transmission path: the T1/n x T1 (or E1/n x E1) between the two PathBuilder S330s, so cells leaving PathBuilder S330 A on VPI/VCI 1/33 arrive at PathBuilder S330 B on VPI/VCI 1/33. Also if the T1/nxT1 (or E1/n x E1) trunk were switched through a standard telephone switching system to interconnect many PathBuilder S330s, each PathBuilder S330 would have to have the same VPI/VCI designations assigned. The ATM switch removes this restriction.

Figure 165 shows several PathBuilder S330/S310s in an ATM-switched network. The switch maps one VPI/VCI into another based on the destination of the packets in the cell. It learns the complete topology of the network to do so. You can independently configure each PathBuilder S330/S310 connected to the switch.

Figure 165 Virtual Circuits in a Switched Network

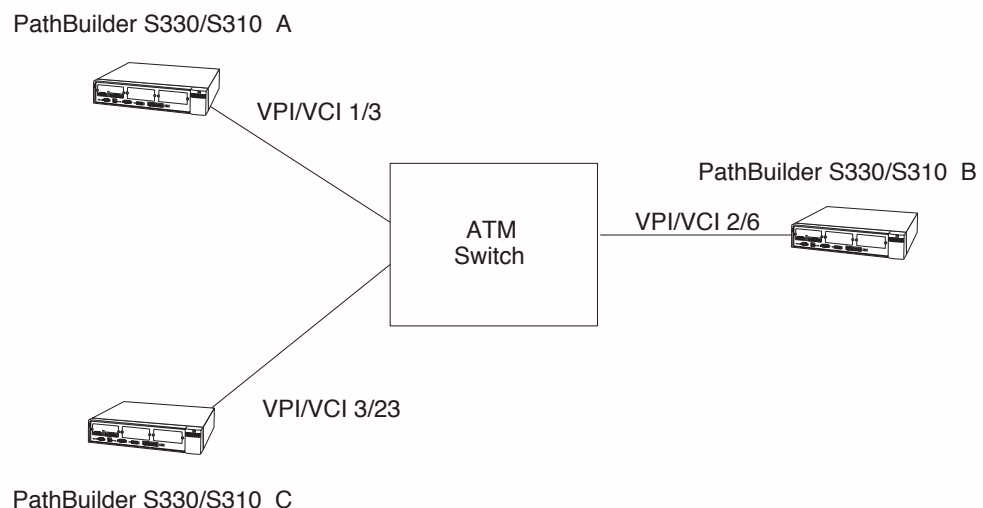

Segmentation

Once it is determined that a packet should go across the bridge, the packet is encapsulated per RFC 1483 and a pad and trailer conforming to AAL5 (ATM Adaption Layer 5) is added at the end of the packet. See Figure 166. The trailer is fixed at eight bytes and contains information such as the new length of the packet and cyclic redundancy check bytes (CRC facilitates error checking at the receive end). The pad is set to 0 to 47 bytes to make the full packet length including the trailer divisible by 48 bytes. The packet with the RFC 1483 encapsulation is then segmented into 48-byte (384-bit) cells by the SAR function.

Figure 166 AAL5 Pad and Trailer

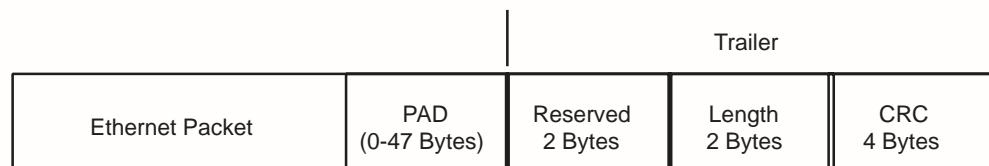

The cells are assigned to a virtual circuit defined between the incoming and outgoing ports based on the destination address of the original packet. A 5-byte header containing the virtual circuit assignment, along with other information, is added to each cell. The cells are queued in the output FIFO (First In First Out memory) of the Ethernet based on the bandwidth and quality of service requirements assigned to the virtual circuit at configuration. The FIFO provides elastic storage between the Ethernet and the CTX.

Reassembly

When the CTX receives a cell from the T1/E1 UNI interface, it broadcasts it to the Ethernet port. As cells are received by the reassembler, their headers are read to determine if they belong to the port. If so, the header is stripped and the cell is stored in memory, appended to the previous ones for that virtual circuit. The system also looks for the AAL5 trailer that signifies the end of a packet. When it finds a trailer, it performs the CRC calculation, checks the length of the cells since the previous trailer to be sure no cells were missed, strips the trailer, appends the cell to the others to reform the original packet, and sends the packet through the Ethernet interface to the LAN.

Typical Ethernet and Voice Application Configurations

A typical Ethernet and voice application configuration involves multiple PathBuilder S330s connected through an ATM network that could consist of simply an ATM switch or of an ATM network consisting of multiple switches. Figure 167 shows the latter configuration.

Figure 167 PathBuilder S330/S310 Application

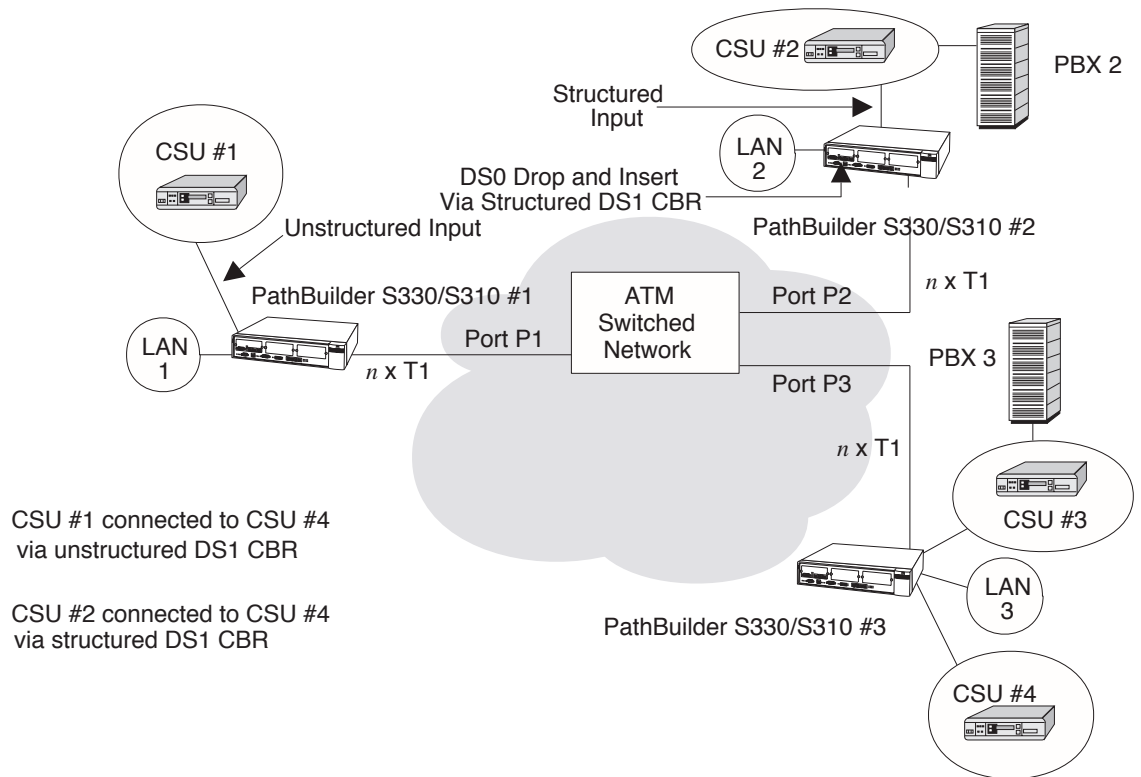

Circuits Set Up on The PathBuilder S330/S310 #1

PVC	END1	END2	VPI/VCI	Conn To
#1	LAN1	T1/nxT1 or E1/nxE1	0/150	LAN2
#2	LAN1	T1/nxT1 or E1/nxE1	0/200	LAN3
#3	CSU1	T1/nxT1 or E1/nxE1	0/250	CSU4

Circuits Set Up By The Carrier (Cross Connects)

PVC	END1	VPI/VCI1	END2	VPI/VCI2
#1	P1	0/150	P2	0/100
#2	P1	0/200	P3	0/100
#3	P2	0/200	P3	0/150
#4	P2	0/450	P3	0/200
#5	P1	0/250	P3	0/250

Circuits Set Up on the PathBuilder S330/S310 #2

PVC	END1	END2	VPI/VCI	Conn To
#1	LAN2	T1/nxT1 or E1/nxE1	0/100	LAN1
#2	LAN2	T1/nxT1 or E1/nxE1	0/200	LAN3
#3	PBX2	T1/nxT1 or E1/nxE1	0/250	PBX3

Circuits Set Up on the PathBuilder S330/S310 #3

PVC	END1	END2	VPI/VCI	Conn To
#1	LAN3	T1/nxT1 or E1/nxE1	0/100	LAN1
#2	LAN3	T1/nxT1 or E1/nxE1	0/150	LAN2
#3	PBX3	T1/nxT1 or E1/nxE1	0/200	PBX2
#4	CSU4	T1/nxT1 or E1/nxE1	0/250	CSU1

Forward and Reverse VCCs Match in This Example. VCCs are Undirectional. Only Forward Vccs are Shown for Easier Viewing.

Figure 168 shows three PathBuilder S330s connected through a carrier ATM network or a private switch. The ATM switch or network should be configured with Permanent Virtual Circuits (PVCs) connecting one LAN or Ethernet port on one PathBuilder S330 to another port on another PathBuilder S330.

Figure 168 ATM Bridging

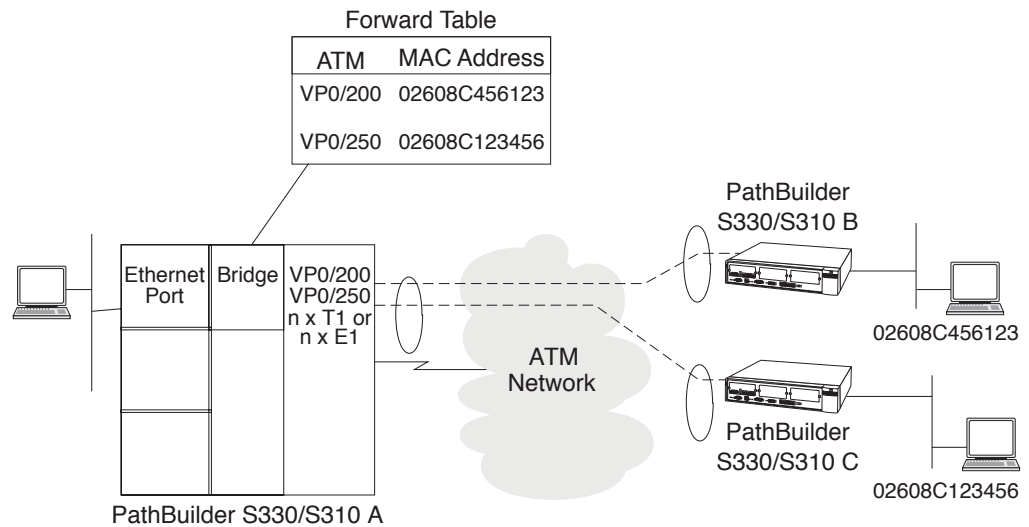

Note that the numbers given for these circuits by the carrier are local to one PathBuilder S330 and have no global significance. For example, VCC number 0/100 is used on two different PathBuilder S330s to mean two different circuits. The carrier will assign each PathBuilder S330 at each location any number of circuits to connect each PathBuilder S330 Ethernet port to any other PathBuilder S330 Ethernet port.

The connections in the carrier network are shown for illustration only. The figure shows an example for an ATM switch configuration. Note that the VCC numbers get translated by the ATM switch since they have local meaning only for every switch port. For example, at the #1 location, the carrier would provide the PathBuilder S330 four VCCs for the forward and reverse path to connect to LAN2 and LAN3 respectively.



VCCs are unidirectional and, therefore, two VCCs are designated on a port of a PathBuilder S330/S310 to transmit to, and receive from, another location.

The PVCs are provisioned by the carrier for use on each PathBuilder S330/S310. These PVCs are entered in circuit tables within each PathBuilder S330/S310. After the circuits are built, the bridge can use this information to send ATM cells to remote sites.

The PathBuilder S330/S310 will support a maximum of 1000 VCs. You first configure each PathBuilder S330/S310 with the PVC information by using screens which prompt you to input specific information about each Permanent Virtual Circuit. See "Configuring Virtual Circuits" in Chapter 4, for details. These PVCs are tied to a specific PathBuilder S330/S310 port (the Ethernet port). The PathBuilder S330/S310 Ethernet port can have several PVCs associated with it.

Each PVC represents the logical circuit being used to connect one PathBuilder S330/S310 port to a remote PathBuilder S330/S310 port. Once you have entered all PVCs, the bridge will learn the network addresses for the local and remote sites and start bridging packets to the correct destination by segmenting the packets into cells which are destined to a remote PathBuilder S330/S310 port. See Figure 168. The ATM network will transport the cells according to the VPI/VCI headers.

Figure 169 shows three PathBuilder S330s configured to provide LAN connectivity between three different LAN segments. Each Ethernet port will run Bridging (Learning) programs to determine if received LAN packets should be passed to the WAN on a specific PVC. In the above example, multi-port bridging software will determine if packets will be passed or dropped. When a packet comes in from LAN 1 port and the Bridge code does not have the destination MAC address associated with one of its logical ports (Ethernet, PVC #1, PVC #2), it will broadcast the packet on all PVCs associated with this port.

Once packets are received from the WAN on specific PVC logical ports, their source addresses will be learned and associated with the logical port. Once you and your carrier have set up PVCs to all remote PathBuilder S330/S310 Ethernet ports, the Bridging code will do the rest.

Figure 169 LAN Connectivity

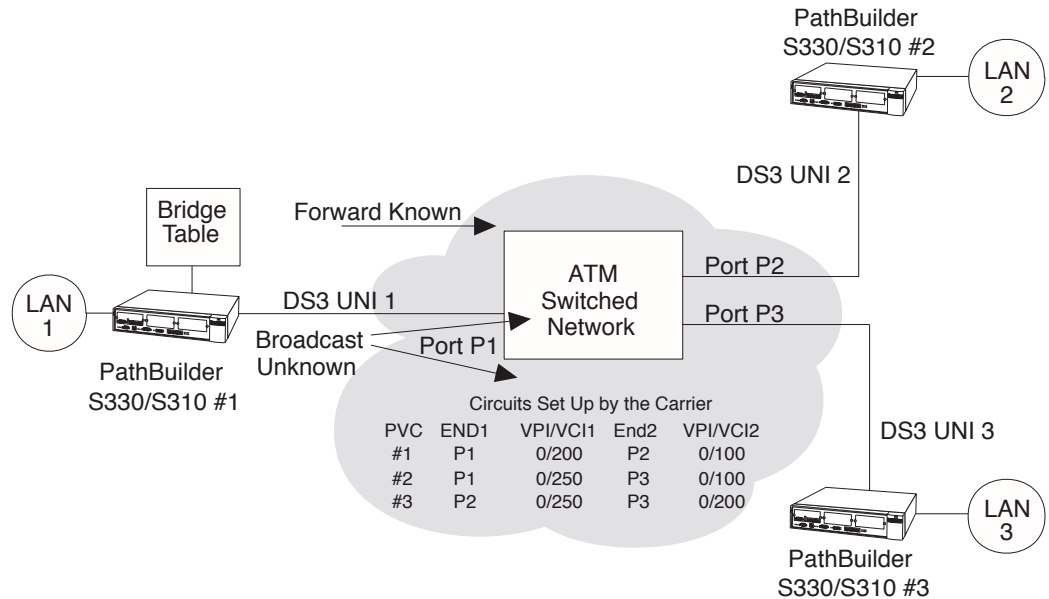

CBR Module

The optional T1-DSX/E1 CBR module provides three T1-DSX or E1 ports (one on the PathBuilder S310) and one serial port. This module services traffic generated by your existing PBXs, channels, T1/E1 multiplexers, CSU/DSUs, and video conferencing devices. This service maps the T1-DSX/E1 service through the AAL1 adaptation layer over a CBR virtual channel connection (VCC). The VCC is established as a permanent virtual circuit (PVC) and mapped from the PathBuilder S330/S310's ATM port to another PathBuilder S330/S310 or an ATM Forum circuit emulation compliant device.

The T1-DSX/E1 inputs can be either ESF, SF, or no-framing using B8ZS or AMI. In accordance with the ATM Forum's Circuit Emulation Service (CES) specifications, the received frame can be broken up into its DSO and ABCD signaling components using structured mode or tunneled through the ATM network using unstructured mode. Structured mode allows DSO mid span drop and insert or grooming.

- In structured format, the data is framed on, then any single 64K channel or a group of timeslots can be selected, grouped and SAR'd to a single ATM connection. In the T1-DSX/E1 format, up to 24 channels, or a combination thereof, can be selected. The timing in structured mode should be loop or system. See "Structured DS1" later in this section for further information on structured service and when to use it.
- In unstructured format, the data is treated as bits in / bits out and is converted into cells with a single VPVC connection. You can select the timing—loop, system, SRTS or adaptive—in unstructured mode. With SRTS timing, the internal system clock on both ends must be traceable to a common source. See "Unstructured DS1" later in this section for details on unstructured service and when to use it.

On the T1-DSX/E1 receive side, the data flow is as follows:

- A line interface unit recovers the digital data.
- The data flows through a framer to extract the serial data stream.
- The data is fed to the AAL1 SAR device.
- The SAR converts the data into ATM cells and tags the cells with the internal VPVC number.
- The cells are passed through a FIFO to the CTX module.

On the T1-DSX/E1 transmit side, the data flow is as follows:

- Cells received from the CTX module are buffered in a 32-cell FIFO to decouple the CTX cells from the SAR. The depth of the FIFO is determined by the CDVT cell delay variation tolerance (CDVT) parameter that you set.
- The cells are fed in the SAR, and the SAR terminates the AAL1 pointer overhead and places the payload in memory. For unstructured data, the clock is recovered using the adaptive or the SRTS technique—or it can be loop-timed. If the SRTS technique is used, the system clocks on both ends must be synchronized.
- The clock and data are sent out to a framer chip where the frame is added and the signal is converted into analog.

An 8 KHz clock is extracted from one of the T1-DSX/E1 clocks and fed to the motherboard connector. This clock is used as one of the options to derive the system clock. The module also accepts an 8 KHz clock from the motherboard to provide the T1-DSX/E1 and serial timing.

For the serial interface, the data is clocked as a serial bit stream and transferred to the SAR, where it is converted into a structured path AAL1 stream. On the receive from the ATM side, the cells are passed from the CTX to the SAR and the original data is recovered. A timing option allows end-to-end clock recovery. The data is then sent serially over the connector. A sensing option in the cable allows automatic detection of DCE and V.35/RS-449 options.

Structured DS1 Implement the structured service if you require DS0 midspan drop-and-insert. (See Figure 170.)

Figure 170 CBR Structured DS1 - Drop and Insert

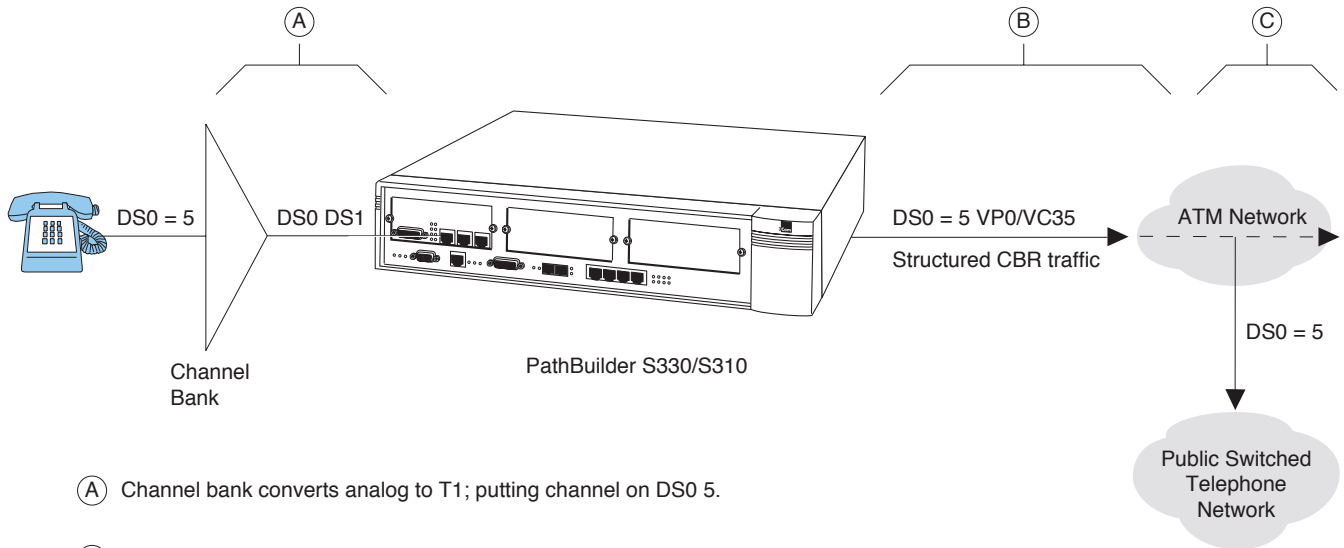

- (A) Channel bank converts analog to T1; putting channel on DS0 5.
- (B) PathBuilder S330/S310 puts DS0 5 on virtual circuit (VP0/VC35) and passes structured CBR traffic through to the ATM network.
- (C) ATM network continues to carry CBR traffic on to another ATM network or drops the traffic (on DS0 5) to a public switched telephone network.

Midspan drop and insert allows services such as public switched telephone service to be inserted into the ATM link. Combining this service with Ethernet bridge service will provide you with a complete integrated communications access solution, as shown in Figure 171.

Figure 171 Integrated PathBuilder S330/S310 Application

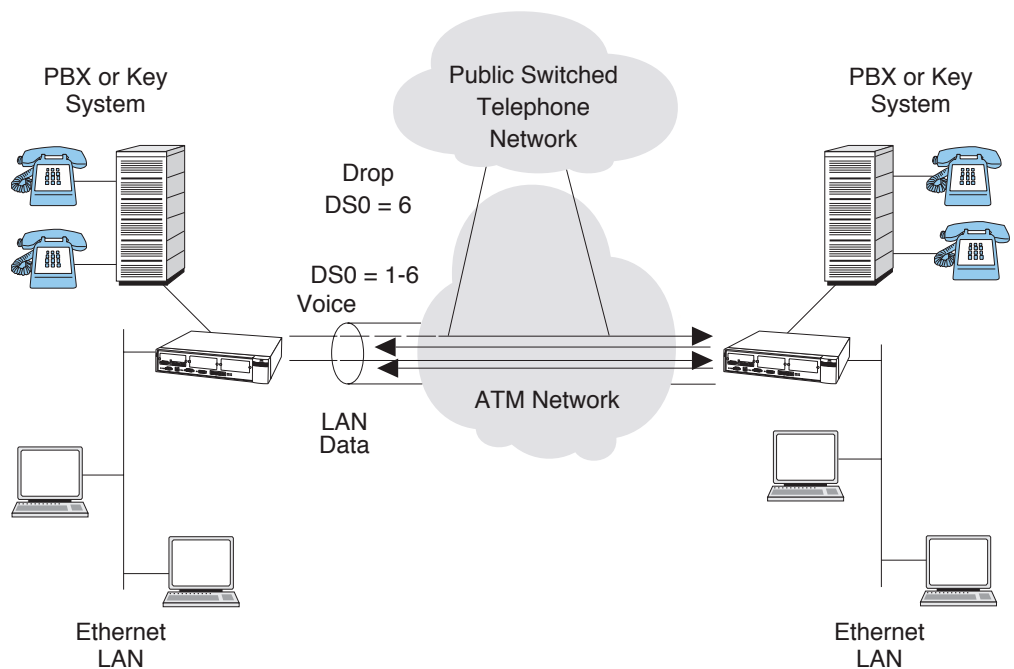

Drop-and-Insert DS0 channels can be allowed to transit the entire path, providing DS0 to DS0 connectivity between end locations. Structured DS0s can also be groomed to be combined through an ATM network, thereby allowing end-to-end DS0 switching, as shown in Figure 172.

Figure 172 Structured DS0 Combining

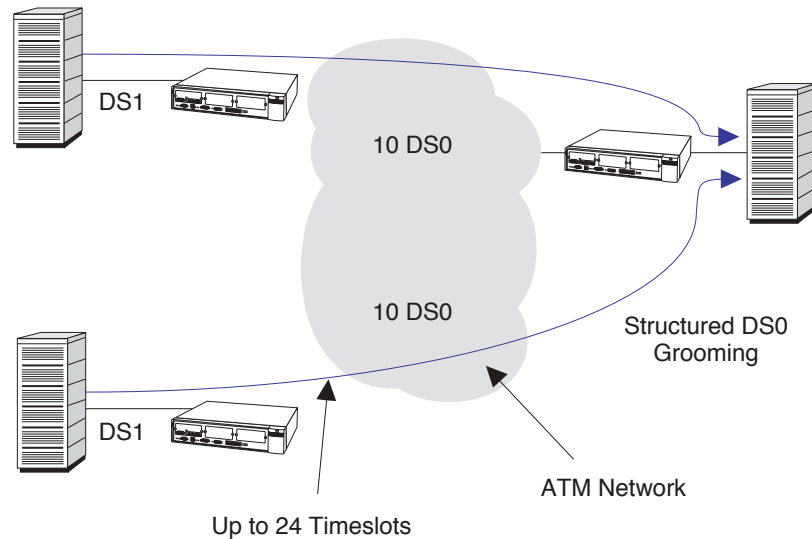

PBX - Private Branch Exchange
VCC - Virtual Channel Connection

DS0 Signaling and Dynamic Bandwidth Allocation

Structured voice DS0s allow for channel-associated signaling by providing a path for DS0 ABCD bits. (See Figure 173.) Channel-associated signaling allows telephone supervision to be signaled end-to-end. Note that structured DS1 CBR occupies only the needed bandwidth for the DS0s selected.

Figure 173 Channel Associated Signaling

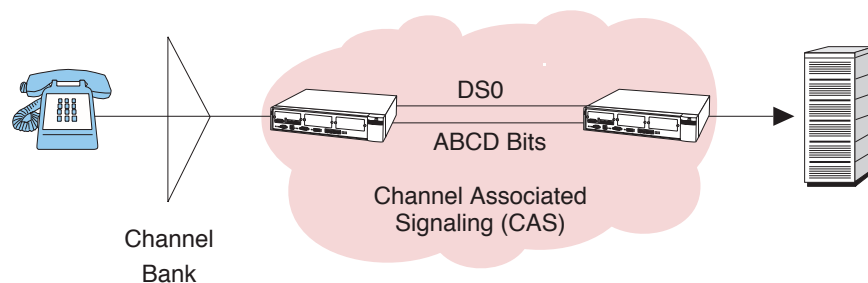

These frames are then followed by the ABCD bits of each active DS0. Two DS0's ABCD bits are provided in each byte after the last DS0 group. Figure 174 shows an example of three DS0s and their ABCD bits sent in a structured encapsulation.

Figure 174 Multiframe Structure for 3x64kbit/s DS1 with CAS

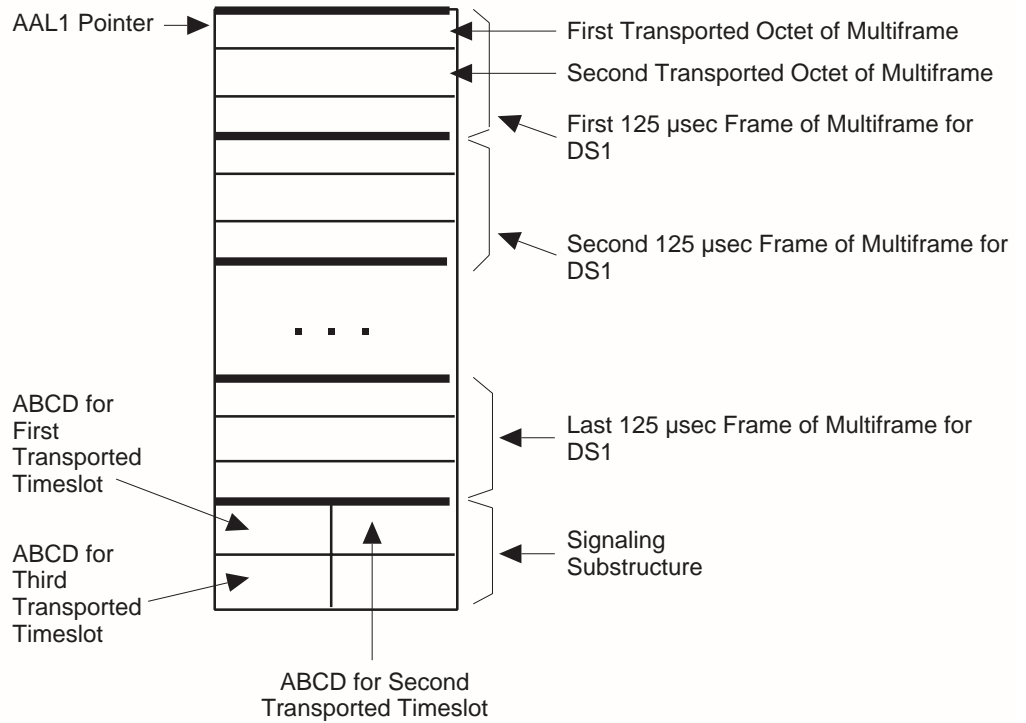
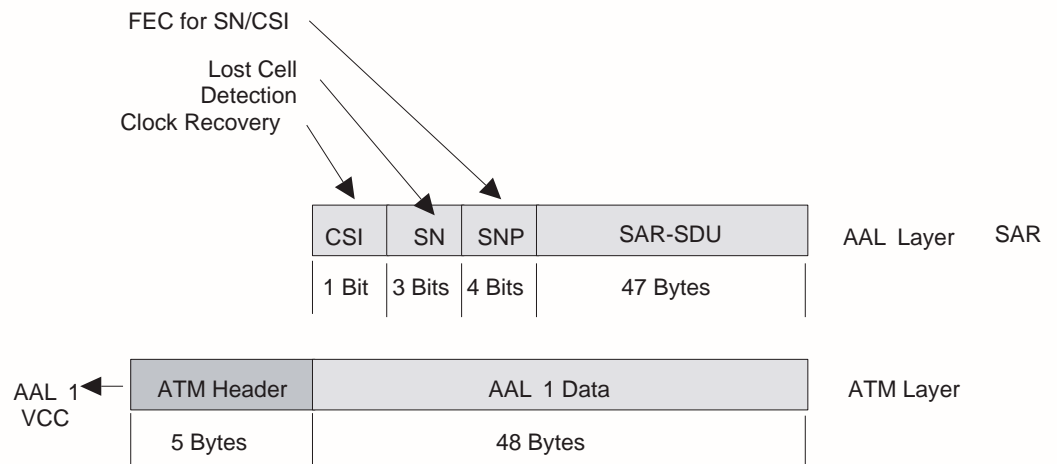

Figure 175 illustrates AAL1 structured DS1.

Figure 175 AAL1 Structured DS1



CSI - Convergence Sublayer Indicator
 FEC - Forward Error Correction
 SNP - Sequence Number Protection
 SN - Sequence Number
 SAR - SDU - Segmentation and Reassembly Service Data Unit
 VCC - Virtual Channel Connection

Structured data DSOs allow for clear channel signaling (CCS). As opposed to CAS, in which signaling is done on all channels, in clear channel signaling (CCS) one channel is used to signal for the other channels.

The PathBuilder S330/S310 software can also monitor a full 8-bit pattern on a DSO to determine circuit activity. This is the basis for the two supported types of dynamic bandwidth allocation (DBA):

- Structured voice DBA
- Structured data DBA

Structured Voice DBA When a CBR port is configured as structured voice, signaling bits of voice channels are carried along with their payload in AAL1 cells. These signaling bits, which are received from T1/E1 framers, are stored in buffers provided in the SAR processor. The CBR software periodically reads the stored signaling bits and checks for an idle condition of voice channels with on-hook detection enabled.

- When an on-hook (idle) signal is detected, the CBR virtual circuit is deactivated, and the bandwidth reserved for that channel is released for other uses (such as VBR traffic).
- When an off-hook signal is detected, the CBR virtual circuit is activated.

Use structured voice circuits with DBA for CAS (channel associated signaling) applications.

Structured Data DBA When a CBR port is configured as structured data, only DSO payload bytes are carried in AAL1 cells. These data cells are stored in buffers provided in the SAR processor. The CBR software periodically reads the stored data bits and checks for an idle code in the stored data bits of each DSO channel. All virtual circuits in the port use a user-selected DBA bit mask to mask off bits that are not a portion of the idle code.

- When an on-hook condition (idle code) is detected, the CBR virtual circuit is deactivated, and the bandwidth reserved for that channel is released for other uses.
- When an off-hook condition (no idle code) is detected, the CBR virtual circuit is activated.

Use structured data circuits with DBA for CCS (clear channel signaling) applications.



A structured DS1 channel will not pass the original DS1 frame to the remote end. For instance, ESF network management will terminate at the PathBuilder S330/S310 on a structured DS1, so CSU-to-CSU Facility Data Link (FDL) communication will not be possible. FDL communication is possible with unstructured DS1.

Unstructured DS1 Implement unstructured DS1 service when you want DS1 tunneling through an ATM system. DS1 tunneling allows an entire DS1 frame, including framing bits, to travel across an ATM network. See Figure 176.

Figure 176 DS1 Unstructured Tunneling

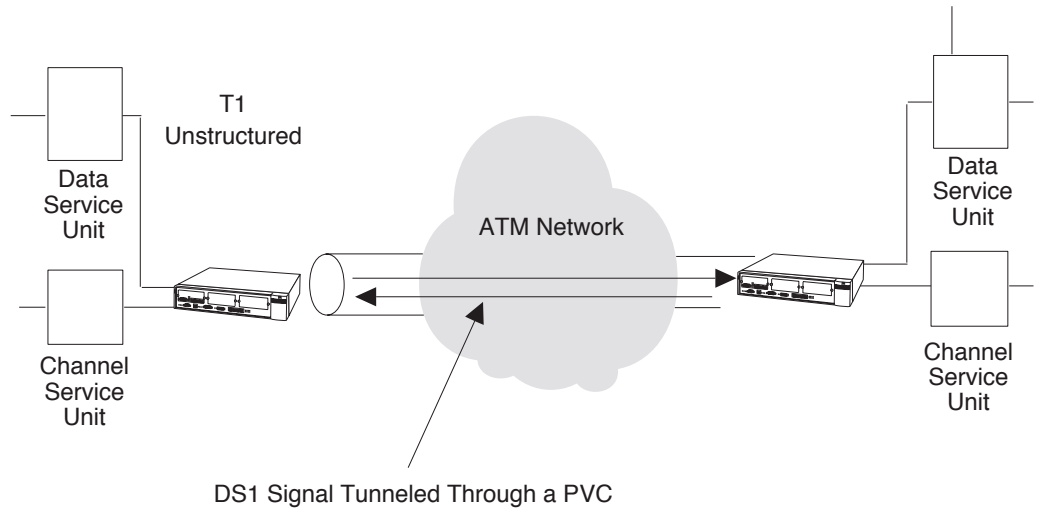

Use unstructured services when DS0 midspan access is not required and end-to-end DS1 service is required; for example, to provide CSU or DSU end-to-end connectivity. The encapsulation of unstructured DS1 occupies DS1 bandwidth on the VCC and uses AAL 1 SAR.

Structured versus Unstructured Summary

Use Table 32 to determine whether to use structured or unstructured DS1 CBR.

Table 32 When to use Structured Versus Unstructured Service

	Structured	Unstructured
DS0 midspan drop and insert	X	
DS0 access grooming	X	
DS1 network management end to end		X
DS1 end to end (no DS0 access)	X	X
DS1 CBR 1.536 Mbps of bandwidth	X	X
DS1 CBR 1.544 Mbps of bandwidth		X
Dynamic Bandwidth Allocation (DBA)	X	

Figure 177 depicts the effects of structured versus unstructured service on the DS1 framing.

Figure 177 Structured Versus Unstructured Effects on Transit DS1

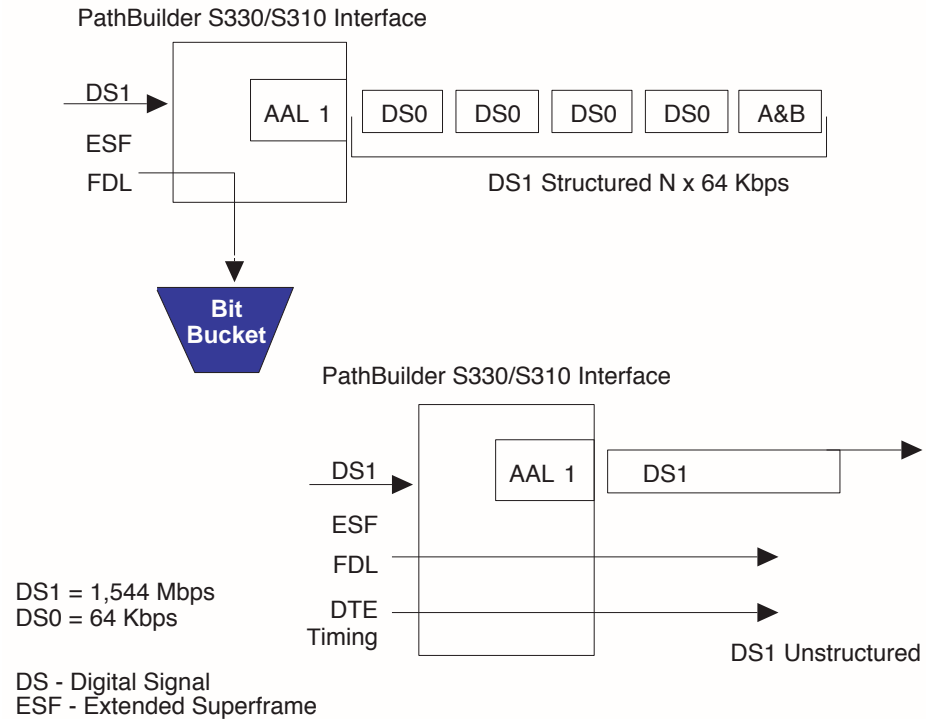

Video Conferencing

The serial port of the PathBuilder S330/S310 CBR module has two types of interface: V.35 for video data and RS-366 for video dial. These interfaces are broken out from a 50-pin connector on the S330/S310 via a Y cable.

The V.35/RS-366 serial CBR connector is ideal for directly connecting to H.320 video codec devices such as PictureTel, Vtel, and CLI. These device applications are used for group-room conferencing applications and distance learning, typically over an ISDN dial network. The PathBuilder S330/S310 platforms simulate a dial ISDN network over an ATM network, allowing you to integrate voice, video, and data on a single ATM network.

The RS-366-based video dial feature allows a dial-based video session using the ATM circuit emulation provided by the PathBuilder S330/S310 platforms. The PathBuilder S330/S310 supports two modes of video conferencing: point-to-point and multi-point.

Point-to-Point Video Conferencing

In point-to-point video conferencing two or more PathBuilder S330/S310 CBR modules are connected via their serial (V.35/RS-366) ports. To set up point-to-point conferencing, you build virtual circuits (defined by transmit and receive vpi/vci combinations) to connect the remote units. To activate a point-to-point conference, both ends must dial their respective destination phone numbers over the RS-366 interface. Video data is then transmitted and received over the V.35 interface. No bandwidth is allocated until the connection is made.

Figure 178 illustrates point-to-point video conferencing between three PathBuilder S330 switches (#1111, #2222, and #3333). Table 33, Table 34, and Table 35 list possible routing tables for the three units.

Figure 178 Point-to-Point Video Conferencing

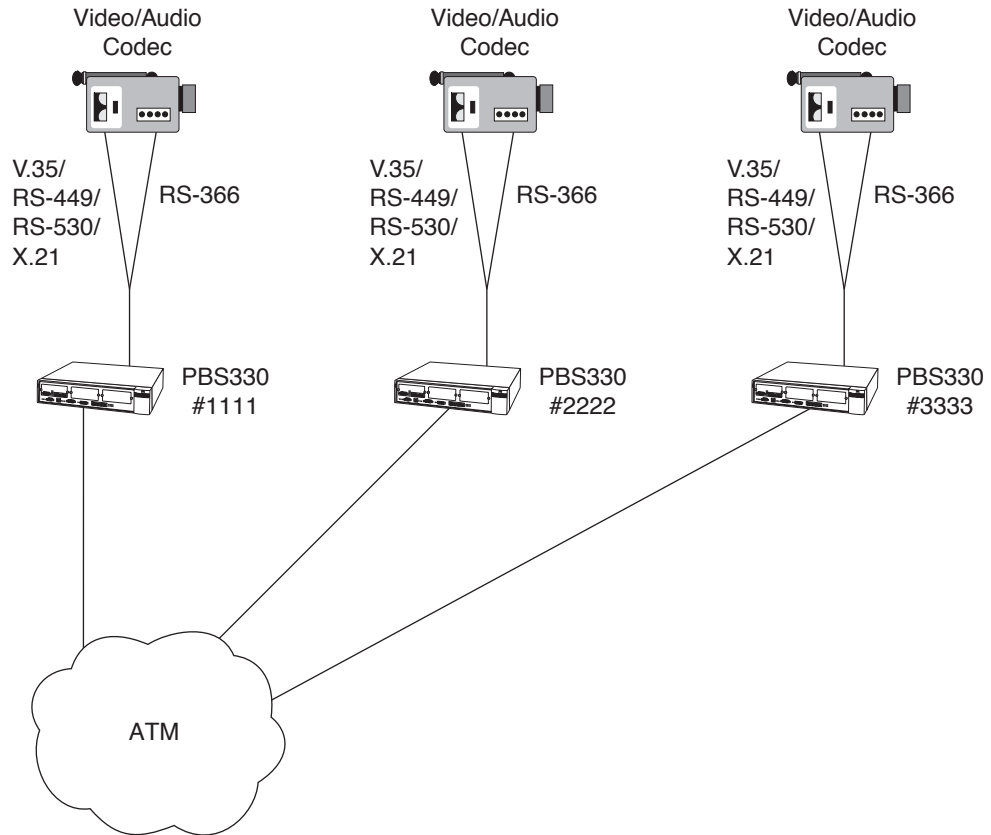

Table 33 Point-to-point Video Conferencing Routing Table (Remote Unit #1111)

Destination #	Tx vpi/vci	Rx vpi/vci	Speed	Status
2222	0/1	0/2	384k	active
3333	0/1	0/3	384k	idle

Table 34 Point-to-point Video Conferencing Routing Table (Remote Unit #2222)

Destination #	Tx vpi/vci	Rx vpi/vci	Speed	Status
1111	0/2	0/1	384k	active
3333	0/2	0/3	384k	idle

Table 35 Point-to-point Video Conferencing Routing Table (Remote Unit #3333)

Destination #	Tx vpi/vci	Rx vpi/vci	Speed	Status
1111	0/3	0/1	384k	idle
2222	0/3	0/2	384k	idle

Multi-point Video Conferencing

In multi-point video conferencing an MCU (Multi Conference Unit) device is connected to one T1-DSX/E1 CBR port of a PathBuilder S600 or PathBuilder S330/S310 at the central site. The remote PathBuilder S330/S310 switches communicate with each other via their serial (V.35/RS-366) ports, as they do in point-to-point video conferencing. In addition, the remote units can communicate with the MCU at the central site over a vpi/vci associated with a fractional T1/E1 bundle of the CBR port connected to the MCU. When a remote unit dials the number associated with that vpi/vci, the central unit sees activity on that line and automatically starts transmitting over the vpi/vci, thus completing the circuit.

Figure 179 illustrates multi-point video conferencing between three remote PathBuilder S330 switches (#1111, #2222, and #3333) and one central PathBuilder S600 switch (#4444) connected to an MCU.

Figure 179 Multi-point Video Conferencing

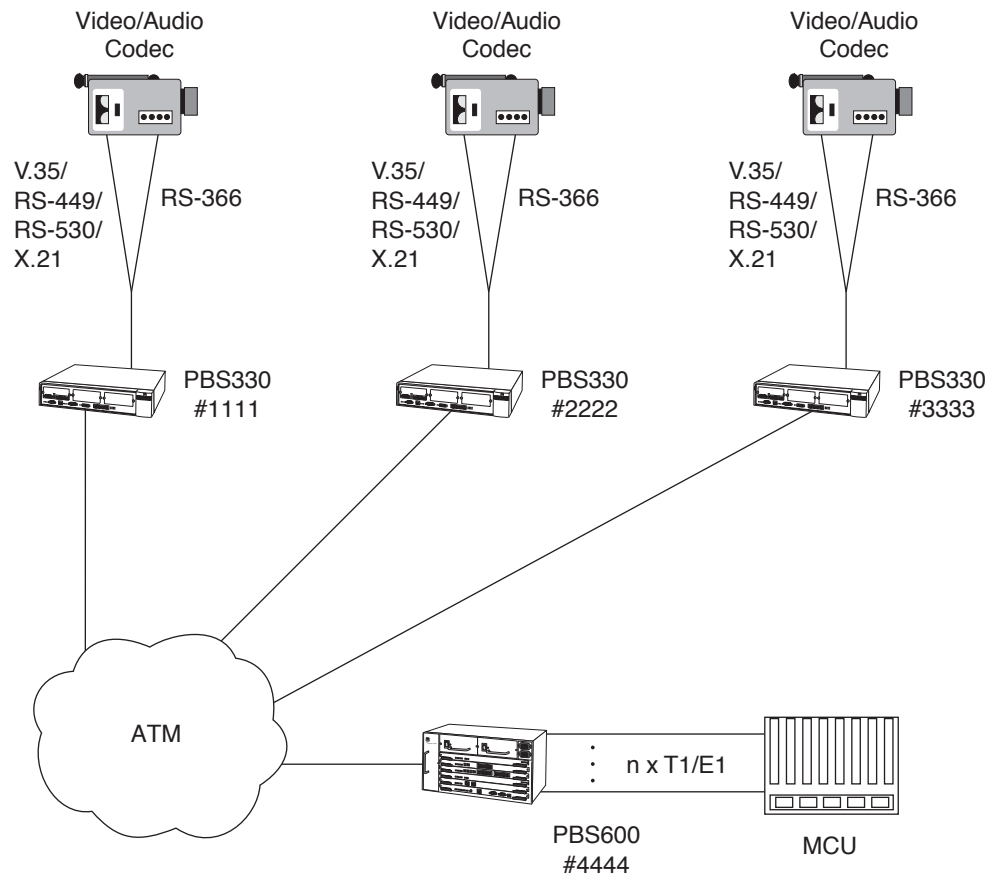

To set up multi-point video conferencing, you build virtual circuits (defined by transmit and receive vpi/vci combinations) between the remote units and between the remote units and the central unit. The remote units can use the same vpi/vci to communicate with the central unit (one at a time), or you can allocate different channels and set up separate virtual connections to each remote unit.

Table 36, Table 37, Table 38, and Table 39 list possible routing tables when the remote units have been allocated different channels on the central unit's T1 line.

Table 36 Multi-point Video Conferencing Routing Table (Remote Unit #1111)

Destination #	Tx vpi/vci	Rx vpi/vci	Speed	Status
2222	0/1	0/2	384k	idle
3333	0/1	0/3	384k	idle
4444	0/1	0/2	384k	active

Table 37 Multi-point Video Conferencing Routing Table (Remote Unit #2222)

Destination #	Tx vpi/vci	Rx vpi/vci	Speed	Status
1111	0/2	0/1	384k	idle
3333	0/2	0/3	384k	idle
4444	0/6	0/7	384k	active

Table 38 Multi-point Video Conferencing Routing Table (Remote Unit #3333)

Destination #	Tx vpi/vci	Rx vpi/vci	Speed	Status
1111	0/3	0/1	384k	idle
2222	0/3	0/2	384k	idle
4444	0/12	0/13	384k	active

Table 39 Multi-point Video Conferencing Routing Table (Central Unit #4444)

Source	Tx vpi/vci	Rx vpi/vci	DSOs
1111	0/2	0/1	channels 0-5
2222	0/7	0/6	channels 6-11
3333	0/13	0/12	channels 12-17

Voice Compression Module

The optional Voice Compression module (VCM) provides one T1 or E1 port. It is similar in function to the CBR module, but it employs compression algorithms that allow more voice calls to be placed through the same bandwidth.

The incoming voice signal is carried on one or more of the T1/E1 port's 24/31 DS0 channels. The voice data in each DS0 channel is in PCM format. This data is compressed by the DSP, and the output from the DSP is encapsulated into FRF.11 packets by the host CPU on the VCM daughtercard. The packets are then passed to the mother board through the PCI interface, handed over to the AAL5 SAR, and transmitted to the ATM interface.

In the reverse direction, compressed voice packets are received by the SAR on the ATM interface in FRF.11 format. The packets are then passed to the VCM daughtercard via the PCI interface. The packets are unpacked by the daughtercard CPU before they are handed to the DSP, which decompressed the voice data and plays out the voice onto the T1/E1 PCM interface.

Supported Voice Compression Features

The VCM supports the following features:

- **G.729A, G.726, and G.711 compression algorithms**—You must configure the voice coding (compression) for each DS0 channel. The decompression runs in the same mode as the compression. In addition, the remote end must be set up to run the same mode as the local end—there is no auto-switching for the voice compression mode. For details about configuring VCM channels, see “Configuring VCM DS0 Channels” in Chapter 4.
- **Voice activity detection**—Voice packets are handled differently in the receive and transmit directions:
 - From T1/E1 line to packet network, the host CPU constantly polls the DSP packet buffers for voice data. When it detects a voice packet, it encapsulates the packet into an FRF.11 subframe and forwards it to an output interface.
 - From packet network to T1/E1 line, FRF.11 packets are decoded, demultiplexed, and sent to the DSP as soon as they are received on the PCI interface.
- **Fax relay**—Fax data is transferred using FRF.11 Fax Relay Transfer. The DSP detects if the fax preamble is a single frequency tone or a non-single frequency tone.
 - If the DSP detects a single frequency preamble, it modulates the fax using modulation type V.21 and transfers the fax data at 300bps using T.30 fax payload format.
 - If the DSP detects a non-single frequency preamble, it modulates the fax using various modulation types and transfers the fax data at 300bps to 14400 bps using T.4 payload format.
- **DTMF relay**—Dialed digits are detected by the DSP and transported using FRF.11 Dialed Digit Payload format. The dialed digit frame is transported only when a DTMF tone is detected. The DTMF tone is generated by the DSP when dialed digits are received through the packet network.

INDEX

Symbols

Rx configured links 103
Tx configured links 102
#Rx active links 103
#Tx active links 103
(DFA) VCI 154
(DFA) VCI range 154
(DFA) VPI 154

Numbers

3Com bulletin board service (3Com BBS) 206
3Com URL 205
3ComFacts 206
56K/64K mode 127

A

AAL5 pad 228
AC or DC Power, connecting 38
activation min. 91
activation rate 91
Add Virtual Circuit screen 136
 initial 135
address translation
 VC and VP 156
address translation, VC and VP 156
Admin Status 105
admin. port(s) 97
admin. status 88, 91, 104, 109, 126, 127, 132
administrative 88
AFA 91
age 120
Alarm History display 178
alarm indicator 62
alarms
 clearing history 178
 common 169
 DS1/E1 UNI module 171
 DSX-1/E1 CBR module 176
 FAM 177
 managing 165
 management CPU 81
 QSIM 177
 system (MCPU/STX) 167
 viewing current 165
 viewing history 178
applications
 DXI 218
 Ethernet/voice 228
 HDLC/SDLC 219
 PathBuilder 330/310 integrated 233
 PathBuilder S330/S310 229
ATM
 overview 209
ATM Cell Mapping 105

ATM DXI mode 215, 217
ATM Payload Scramble 105
ATM payload scramble 104
ATM statistics 189, 191, 192, 193, 194, 198
Automatic Frequency Adjustment See AFA.

B

bit error rate 91
 translated into total # of errors 92
Bridge 120, 195
bridge
 addressing 224
 ATM 230
 configuring 112
 Ethernet statistics 196
 filtering 223
 principles of operation 223
 reassembly 228
 segmentation 228
 statistics 195
Bridge Configuration menu 113
Bridge menu 114
Bridge Setup menu 116
Bridge Static Table 120
 constructing 120
Bridge Static Table menu 120
Bridge Topology Changed 196
bridging. See bridge. 223
Broadcast Frames 195
buffers
 congestion thresholds 87
 virtual circuit statistics 204
bulletin board service 206

C

call routing table (video), viewing 162
Canadian CS-03 Approval Information xi
card type 81
cards
 configuring 86
CAS. See channel associated signaling
CAS. See channel associated signaling.
CBR card
 configuring 128
CBR module
 ATM statistics 198
 configuring 121
 configuring circuits for clear channel signaling 140
 configuring circuits for structured data DBA 140
 configuring circuits for structured voice DBA 140
 data flow 232
 installed 34
 LEDs 55
 line build outs 53, 55
 loopbacks 182
 performance monitoring 197
 principles of operation 231
 setting ports and circuits for CAS versus CCS 139
 specifications 24
 T1-DSX/E1 LEDs 55, 56
CBR port modes
 structured 232, 233
 unstructured 123, 124, 232
CBR serial port
 configuring 126, 127
CBR T1-DSX and V35 Configuration menu 122
CBR T1-DSX ports
 configuring 121
CBR T1-DSX timing options 125
CBR traffic 211
CCS. See common channel signaling
CDV buffer size 155
CE Notice xii
cell loss integration period 155
channel associated signaling 139, 140, 234
 multiframe structure for 3x64kbit/s DS1 235
clear channel signaling 140
clock. See system clock.
common channel signaling 139, 140, 141, 198
communication parameters, setting 63, 64
community name
 setting for Ethernet port 66
compression algorithm, selecting 130
configuration
 bridge 112
 cards and ports 86
 CBR card 128
 CBR module 121
 CBR serial port 126, 127
 CBR T1-DSX ports 121
 communication parameters 63, 64
 CTX 85
 default gateway 68
 DS3 UNI module 105
 Ethernet card 104, 111, 112
 IMA groups 92
 in-band management 72
 initial 63
 local host IP address 65
 management CPU 75
 management CPU shapers 83, 85
 menu 81
 OC3/STM-1 port 104
 ports 88
 RS-232 port 77
 serial card 110
 serial port 107, 108

- system clock 63
- system information 75, 76
- T1/E1 card 103
- T1/E1 ports 89, 90
- T1/E1 UNI interface 89
- time and date 69
- trap clients 67
- UNI groups 92
- VCM card 133
- VCM channels 129
- VCM T1/E1 ports 130
- viewing RS-232 port settings 77
- viewing shelf information 82
- virtual circuits 133
- voice compression module 129
- VT100 59

Configuration Management (Main menu option) 61

Configuration Management menu 81

Configuring 121

Congested Frames 194

congestion thresholds 87

- setting 88

connections

- AC/DC power 38
- Ethernet port 51
- I/O cabling 40
- management terminal 57, 58, 59
- OC3/STM-1 port 52
- OC3/STM-1 port (multi-mode fiber) 52
- OC3/STM-1 port (single-mode fiber) 52
- port 41
- serial port 42
- T1/E1 UNI interface 42

connectivity

- LAN 231

Connector 50

Connector pinouts. *See* pinouts.

conventions 2

- notice icons 2
- text 2

CRC-4 126, 132

CTS&DCD option 128

CTX 209

- configuring 85

CTX Buffers menu 87

CTX menu 85

CTX Queue Buffer Configuration menu 87

CTX Shapers menu 86

Current Alarm display 166

D

Data Bytes

- checking to determine DBA Bits mask setting 139

Data Bytes To 198

data flow

- CBR module 232
- OC3/STM-1 port 213
- T1/E1 UNI interface 212

data rate 109

database, erasing 71

DBA Bits Mask 198

DBA *See* dynamic bandwidth allocation

DE to CLP mapping 153

- deactivation min. 91
- deactivation rate 91
- Default Gateway Configuration menu 68
- default gateway, configuring 68
- Designated Bridge ID 196
- dest phone # 163
- Destination Address Filter menu 118
- destination address filtering 118
- DFA
 - mapping in the DXI frame 218
- diagnostics 165
- dial timer 128
- Discarded Frames 195
- disp. (disposition) 119
- drop and insert 233
- DS0 combining (structured) 234
- DS1 UNI interface. *See* T1/E1 UNI interface.
- DS1 UNI. *See* T1 UNI.
- DS1/E1 UNI module
 - alarms 171
- DS3 105
- DS3 Framing Mode 105
- DS3 timing source 106
- DS3 UNI Configuration menu 105
- DS3 UNI module
 - configuring 105
 - effects of installing on IMA
 - Group 1 57, 92
 - LEDs 57
 - loopback options 181
 - loopbacks 181
 - performance monitoring 192
- DSR option 128
- DSX-1/E1 CBR module
 - alarms 176
- DTMF Level 130
- DXI applications 218
- DXI Format Mode 1A 217
- DXI frame 218
- DXI protocol 216
- DXI protocols
 - See also* ATM DXI mode.
- dynamic bandwidth allocation 139, 140

E

E1 UNI interface. *See* T1/E1 UNI interface.

E3 timing source 106

E3 UNI module

- effects of installing on IMA
 - Group 1 57, 92
- loopback options 182
- loopbacks 182
- performance monitoring 193

early packet discard 151, 156, 212

Echo Cancellation 130

EMI x

encapsulation mode 152

- transparent (FRF.8) 152

Encoding 130

equipment list 80

Ethernet card

- configuring 104, 111, 112

Ethernet card. *See also* Ethernet interface.

Ethernet Configuration Port/Card Selection menu 111

Ethernet interface. *See also* Ethernet port, Ethernet card.

Ethernet port

- connecting 51
- LEDs 51
- principles of operation 222
- virtual circuit parameters 154

Ethernet Port IP Configuration menu 66

Ethernet port. *See also* Ethernet interface.

Ethernet/voice applications 228

external timing 214

F

failure 102

FAM

- alarms 177

Fault Management (Main menu option) 61

Fault Management menu 165

FAX Modem Support 130

fax service (3ComFacts) 206

FCC Part 68 Statement xi

FCS Errors 194, 200

FE Number of Failures 188

FE Rx failure 99

FE Rx state 99

FE state 101

FE Tx state 99

FEAC Loopback 106

FECN to EFCI mapping 154

filtering

- destination address 118
- source address 116, 117
- source protocol 114, 115
- statistics 195

firmware

- downloading new 78
- viewing version number 77

flash file system, updating 80

Flooded Frames 195

Forward Delay 197

Forwarded Frames 195

Frame Length 96

frame length 96, 97

frame protocol modes 214

Frame Relay DLCI 152

Frame Relay mode 219

framing 91, 124, 132

FR-SSCS DLCI 153

full system configuration

- PathBuilder 310 32
- PathBuilder 330 31

G

gain limit 91

General System Information menu 76, 77

getting started 59

group 92

- partitioning 211

Group menu 93, 95

groups

- adding 92
- adding IMA 94
- adding UNI 92
- deleting 97

deletion of Group 1 when DS3/E3 module installed 57, 92
 modifying 97
 selecting type (IMA or UNI) 94, 96

H

HDLC/SDLC applications 219
 HDLC/SDLC mode 219
 Hello Time 197

I

I/O Cabling, connecting 40
 icons, notice 2
 idle timer 125
 IMA
 See also inverse multiplexing.
 group queues 211
 IMA group status, viewing 100
 IMA groups
 adding 94
 configuring 92
 deleting 97
 modifying 97
 viewing or modifying existing 97
 IMA ID 96
 IMA link status, viewing 98
 inband lpbk 91
 in-band management, configuring 72
 in-band virtual circuit 137
 index 163
 installation 29
 general procedure 30
 in a rack 38
 optional modules 35
 overview 30
 procedures 33
 rack mounting 37
 site requirements 32
 interface card, resetting 80
 internal timing 214
 interworking
 network 221
 service 220
 interworking mode 152
 inverse multiplexing 3, 7
 Inverse Multiplexing Algorithm. See IMA.
 IP address
 setting Ethernet port 66
 setting for in-band circuit 151
 specifying for default gateway 68
 specifying for trap client 68
 IP host setup 66

L

LAN connectivity 231
 LBO Length 105
 LBO. See line build out.
 least delay link 102
 LEDs
 CBR module 55, 56
 common 40, 41
 DS3 UNI module 57
 Ethernet port 51
 LOCD (RED) DS3 57
 LOF (RED) DS3 57
 LOS (RED) DS3 56

management CPU 81
 normal startup sequence 40
 OC3/STM-1 port 53
 serial port 50
 T1/E1 UNI interface 42
 line build out 123, 131
 line code 91, 123, 132
 link type 108
 List Card menu 82
 List Forwarding Table 119
 List Virtual Circuit Detail screen 157, 158
 List Virtual Circuit Summary screen 157
 LMI Configuration menu 109
 Local Card 181, 182
 local card loopback 180
 local host IP address
 configuring 65
 Local Host IP Configuration menu 65
 local management interface. See LMI.
 location 119
 logging on 59
 Loopback menu 179
 OC3/STM-1 180
 loopbacks 179
 CBR T1-DSX/E1 182
 local card 180
 network 182, 183
 network line 180
 OC3/STM-1 181
 OCC3/STM-1 181
 T1/E1 UNI interface 180
 LOS 56

M

M Factor See Multiplex (M) Factor
 MAC address 119
 MAC MTU Exceeded 195
 Main menu 60
 options 61
 Manage Bridge menu 113
 Manage IP Network Configuration menu 65
 Manage Video Dial menu 160
 Management 57, 209
 management CPU 151, 209
 alarms 81
 configuring 75
 configuring shapers 83
 LEDs 81
 viewing configuration information 83
 management terminal
 connecting 57, 58, 59
 max. link delay 96
 Maximum Age 197
 MCPU Shapers screen 84
 MCPU. See management CPU.
 memory partition
 See also buffers.
 Menus 61
 menus
 changing settings on 62
 hierarchy 61
 how to navigate 61
 min oper. ports 96
 min startup ports 96
 min. flag bytes 109
 modes
 ATM DXI 215, 217

frame protocol 214
 Frame Relay 219
 HDLC/SDLC 219
 protocol 214
 module and application overview 209
 Multiplex (M) Factor 130
 multi-point video conferencing 141, 240

N

NE Number of Failures 188
 NE Rx failure 99
 NE Rx state 99
 NE state 101
 NE state last changed 102
 NE Tx state 99
 Network Card 181, 182
 network interworking 221
 Network Line 181, 182
 network line loopback 180
 network loopback 182, 183
 network supplier support 206
 noise injection 130
 notice icons 2
 num. of IMA group(s) 103

O

OC3/STM-1 port 213
 configuring 104
 connecting 52
 connecting (multi-mode fiber) 52
 connecting (single-mode fiber) 52
 data flow 213
 LEDs 53
 loopbacks 181
 principles of operation 213
 statistics 189
 virtual circuit parameters 151
 OC3/STM-1 UNI port
 ATM statistics 189
 online technical services 205
 oper. link delay. See operational link delay
 operation group 103
 operation LDS. See operation link delay.
 operation link delay 100
 operation port(s) 101
 operational link delay 102
 operational status 88
 optional modules
 installing 35
 ordering additional equipment 27
 output queues
 priorities 211
 output queues. See also buffers. 210

P

Part # 81
 partial packet discard 212
 parts list 27
 passwords
 changing default 63, 70
 default 60
 setting 69
 PathBuilder 27
 Pathbuilder 330
 features 5

- PathBuilder 330/310
 - external connections 31
 - integrated application 233
 - port configuration 41
 - receiving and inspecting 29
 - PathBuilder S310
 - upgrading to PathBuilder S330 8
 - PathBuilder S330/S310
 - applications 229
 - key benefits 7
 - overview 3
 - PathBuilder S330/S310. *See also* PathBuilder S330/S310.
 - Payload 155
 - payload size 155
 - pecifications 8
 - Performance Management (Main menu option) 61
 - Performance Management menu
 - OC3/STM-1 189
 - performance monitoring
 - CBR module 197
 - voice compression module 199
 - performance statistics 185
 - permanent virtual circuits. *See* PVCs.
 - pinouts
 - CBR module 15, 17, 24, 26
 - CBR V.35/RS-366 54
 - Ethernet interface 10, 19
 - management interface 19
 - OC3/STM-1 interface 11, 21
 - serial interface (V.35) 21
 - serial port (RS-449 DCE cable) 46
 - serial port (RS-449 DTE cable) 45
 - serial port (RS-530 DCE cable) 48
 - serial port (RS-530 DTE cable) 47
 - serial port (V.35 DCE cable) 44
 - serial port (V.35 DTE cable) 43
 - serial port (X.21 DCE cable) 50
 - serial port (X.21 DTE cable) 49
 - T1/E1 UNI interface 10, 20
 - PLCP Timing Source 106
 - point-to-point video conferencing 141, 238, 239
 - port 154
 - port configuration 41
 - port mode 123
 - port number (trap client parameter) 68
 - ports
 - configuring 86, 88
 - See also* names of specific ports.
 - power
 - connecting 38
 - shelf fill 39
 - specifications 38
 - power and power cords x
 - power requirements 18, 38
 - power supply, connecting 38
 - PRI PBX tie line, setting up 141
 - priority 151
 - product benefits 7
 - product features 5
 - product overview 3
 - protocol modes 214
 - protocols
 - DXI 216
 - PVC virtual circuits
 - definition 134
 - PVCs
 - mapping over ATM 215
 - PVCs. *See also* virtual circuits.
-
- Q**
- QSIM
 - alarms 177
 - QSIM V.35/RS-449/RS-530/X.21 port. *See* serial port.
-
- R**
- rack mounting ix, 37, 38
 - read-write privileges 61
 - read-write session, taking over 71
 - receive timing phase 108
 - receive VPI 151
 - Received Frames 194, 196
 - Receiving 29
 - receiving and inspecting 29
 - Redundant Power Supply 38, 39, 40
 - See also* power supply.
 - reference clock. *See* system clock.
 - reference port 104
 - regulatory information ix, xi
 - resetting interface card 80
 - resetting system 71
 - returning products for repair 208
 - revision number 81
 - Root Bridge 196
 - Root Path Cost 197
 - RPS. *See* Redundant Power Supply.
 - RS-232 port
 - entering initial configuration information 77
 - viewing configuration information 77
 - RS366 (video) virtual circuit
 - adding 142
 - RS366 (video) virtual circuits
 - definition 134
 - RS-449 port. *See* serial port.
 - RS-530 port. *See* serial port.
 - Running Secs 188
 - Rx avable cell rate (cps) 102
 - Rx framer length 102
 - Rx IMA ID 102
 - Rx LID 92, 100
 - Rx test pattern 100
 - Rx timing ref. link 102
 - Rx vpi/vci 163
-
- S**
- safety classification of ports x
 - SAP Filtered 195
 - SCR clock source 127
 - SCT clock source 127
 - SCTE clock source 127
 - SCTE timing source 127
 - serial card
 - configuring 110
 - serial interface 213
 - ATM DXI Mode 1A 214
 - CBR 53, 238
 - protocol modes 214
 - See also* serial port, serial card.
 - timing 214
 - serial number 81
 - serial port
 - ATM VC statistics 194
 - configuring 107, 108
 - connecting 42
 - LEDs 50
 - pinouts (RS-449 DCE cable) 46
 - pinouts (RS-449 DTE cable) 45
 - pinouts (RS-530 DCE cable) 48
 - pinouts (RS-530 DTE cable) 47
 - pinouts (V.35 DCE cable) 44
 - pinouts (V.35 DTE cable) 43
 - pinouts (X.21 DCE cable) 50
 - pinouts (X.21 DTE cable) 49
 - principles of operation 213
 - statistics 193
 - statistics (Frame Relay) 194
 - statistics (HDLC) 194
 - virtual circuit parameters 151, 154
 - service interworking 220
 - servicing ix
 - shaper number 151, 154
 - See also* MCPPU Shapers screen.
 - shapers
 - configuring 83, 85
 - shelf
 - viewing configuration information 82
 - Signaling 132
 - signaling 126
 - signaling type 125, 155
 - silence compression 130
 - Silence Compression & Noise Injection 130
 - SIM Configuration Port/Card Selection menu 107
 - SIM Port Configuration Port/LMI Selection menu 107
 - site requirements 32
 - slot # 81
 - Sonet interface mode 104
 - Source Address Filter menu 117
 - source address filtering 116
 - configuring 117
 - Source Protocol Filter menu 115
 - source protocol filtering 114, 115
 - Spanning Tree
 - enabling and disabling 121
 - instances 225
 - operation 224
 - VC-VC bridging operation 225
 - specifications 8, 32
 - AC/DC power 38
 - CBR module 15, 17, 24, 26
 - Ethernet interface 10, 19
 - management interface 9, 19
 - motherboard 9, 18
 - OC3/STM-1 interface 11
 - serial Interface 21
 - T1/E1 UNI interface 10, 18
 - Specifying 77
 - speed 163
 - Statistics 189
 - statistics
 - bridge 195
 - bridge filtering 195
 - OC3/STM-1 port 189
 - performance 185
 - serial port 193
 - serial port (Frame Relay) 194
 - serial port (HDLC) 194
 - Spanning Tree 196
 - T1/E1 UNI Interface 186
 - virtual circuit 200

- virtual circuit (by buffer) 204
- virtual circuit (by circuit) 201
- virtual circuit (by port/group) 202
- virtual circuit (by shaper) 202
- status 163
- structured mode 123, 232, 233
- structured service
 - as opposed to unstructured 237
 - effects on transit DS1 238
- subnet mask
 - setting for Ethernet port 66
 - setting for in-band circuit 151
 - specifying for default gateway 68
 - specifying for trap client 68
- Super User Privilege menu 70
- System Administration (Main menu option) 61
- System Administration menu 63, 75, 76
- system clock
 - assigning priorities 63
 - configuring 63
- System Clock Configuration menu 64
- system configuration
 - initial 63
- system description 3
- system information
 - viewing and configuring 75, 76

T

- T1 (DS1) Port Configuration menu 90
- T1 (DS1) UNI Configuration menu 89
- T1 (DS1) UNI Port Selection menu 90
- T1 UNI interface. See T1/E1 UNI interface.
- T1/E1 card
 - configuring 103
- T1/E1 ports
 - configuring 89, 90
 - virtual circuit parameters 151
- T1/E1 UNI Configuration menu 89
- T1/E1 UNI interface 3
 - configuring 89
 - connecting 42
 - data flow 212
 - LEDs 42
 - loopbacks 180
 - overview 3
 - principles of operation 212
 - specifications 10
 - statistics 186
- TC signaling type 124, 132
- TC1 signaling bits 124, 132
- TC2 signaling bits 124, 132
- technical support
 - 3Com URL 205
 - bulletin board service 206
 - fax service 206
 - network suppliers 206
 - product repair 208
- terminal timing source 108
- test link 96
- test pattern 96
- test procedure 96, 100
- Time and Date Configuration menu 69
- time and date, setting 69
- timing 91
 - CBR T1-DSX options 125
 - external 214
 - internal 214
- timing source 104
- title screen 60
- traffic contract 215
- translation encapsulation mode 153
- transmit VCI 151
- transmit VPI 151
- Transmitted Frames 194, 196
- transparent encapsulation mode (FRF8) 152
- Trap Client 1 Configuration menu 67
- Trap Client Configuration menu 67
- trap clients, configuring 67
- troubleshooting 165
- trunk conditioning 123, 126
- tunneling, unstructured 237
- Tx avable. cell rate (cps) 102
- Tx LID 92, 100
- Tx timing ref. link 102
- Tx vpi/vci 163

U

- Unavailable Secs 188
- UNI groups
 - adding 92
 - configuring 92
 - deleting 97
 - modifying 97
- unstructured mode 124, 232
- unstructured service
 - as opposed to structured 237
 - effects on transit DS1 238
- unstructured service (DS1) 237
- unstructured tunneling 237
- upgrades, from PathBuilder S310 to PathBuilder S330 8
- URL 205

V

- V.35 interface speed 127
- VC and VP address translation 156
- VC statistics 200
- VCI ranges 212
- VCM Configuration menu 131
- VCM Port Configuration menu 131
- VCM See voice compression module
- version number, firmware 77
- video
 - CBR module 231
 - conferencing 238
- Video Call Routing Table 163
- video conferencing 238
 - multi-point 141, 240
 - point-to-point 141, 238, 239
- video dial
 - defining virtual circuits for 141
 - ending video dial-up sessions 162
 - how connection established 141
 - how feature works 141
 - managing 160
 - setting up a session 161
 - starting video dial-up sessions 161
 - viewing call routing table 162
- video dial feature 238
- Virtual Channel Identifier (VCI) 133
- Virtual Circuit menu 134
- Virtual Circuit Statistics by Shaper Detail screen 203

- Virtual Circuit Statistics by Shaper Summary screen 203
- virtual circuits
 - adding 134
 - adding RS366 (video) 141, 142
 - classes of 134, 135
 - configuration parameters 142, 154
 - configuration parameters (OC3/STM-1 port) 151
 - configuration parameters (serial port) 151
 - configuration parameters (serial port, DXI) 154
 - configuration parameters (serial port, Frame Relay) 152
 - configuration parameters (serial port, HDLC/SDLC) 154
 - configuration parameters (T1/E1 port) 151
 - configuring 133
 - configuring for clear channel signaling 140
 - configuring for structured data DBA 140
 - configuring for structured voice DBA 140
 - defining side A for video circuit 142
 - deleting 160
 - in a simple network 226
 - in a switched network 227
 - in-band 137
 - modifying 159
 - overview 211
 - PVC (definition) 134
 - PVC vs. RS366 (video) 134, 135
 - RS366 (video) 134
 - scheme 226
 - statistics 200
 - statistics (by circuit) 201
 - statistics (by port/group) 202
 - statistics (by shaper) 202
 - statistics by buffer (queue) 204
 - types of 136
 - VCM parameters 156
 - viewing existing 156
- Virtual Path Identifier (VPI) 133
- Virtual Statistics Summary screen 201
- voice compression module
 - Configuration menu 131
 - performance monitoring 199
- voice compression module (VCM)
 - configuring 129
 - configuring channels 129
 - configuring the card 133
 - configuring the T1/E1 port 130
 - VC statistics 200
 - virtual circuit parameters 156
- Voice Compression, voice compression module (VCM)
 - selecting compression algorithm 130
- VPC 136
- VPI and VCI ranges 212
- VT100
 - configuring 59

W

- warning information ix

X

- X.21 port. See serial port.

3Com Corporation LIMITED WARRANTY

HARDWARE

3Com warrants its hardware products to be free from defects in workmanship and materials, under normal use and service, for the following lengths of time from the date of purchase from 3Com or its authorized reseller:

Network Interface Cards	Lifetime
Other hardware products *unless otherwise specified above	1 year*
Spare parts and spares kits	90 days

If a product does not operate as warranted above during the applicable warranty period, 3Com shall, at its option and expense, repair the defective product or part, deliver to Customer an equivalent product or part to replace the defective item, or refund to Customer the purchase price paid for the defective product. All products that are replaced will become the property of 3Com. Replacement products may be new or reconditioned. Any replaced or repaired product or part has a ninety (90) day warranty or the remainder of the initial warranty period, whichever is longer.

SOFTWARE

3Com warrants that the software programs licensed from it will perform in substantial conformance to the program specifications therefor for a period of ninety (90) days from the date of purchase from 3Com or its authorized reseller. 3Com warrants the media containing software against failure during the warranty period. No updates are provided. 3Com's sole obligation with respect to this express warranty shall be (at 3Com's discretion) to refund the purchase price paid by Customer for any defective software products, or to replace any defective media with software which substantially conforms to applicable 3Com published specifications. Customer assumes responsibility for the selection of the appropriate applications program and associated reference materials. 3Com makes no warranty or representation that its software products will meet Customer's requirements or work in combination with any hardware or applications software products provided by third parties, that the operation of the software products will be uninterrupted or error free, or that all defects in the software products will be corrected. For any third party products listed in the 3Com software product documentation or specifications as being compatible, 3Com will make reasonable efforts to provide compatibility, except where the non-compatibility is caused by a "bug" or defect in the third party's product.

YEAR 2000 WARRANTY

In addition to the Hardware Products Warranty and Software Products Warranty identified above, 3Com warrants that all Heritage 3Com products sold or licensed to Customer on and after January 1, 1998 that are date sensitive will continue performing properly with regard to such date data on and after January 1, 2000, provided that all other products used by Customer in connection or combination with the 3Com products, including hardware, software, and firmware, accurately exchange date data with the 3Com products, with the exception of those products identified at 3Com's Web site, <http://www.3com.com/products/yr2000.html>, as not meeting this standard. A product is considered a "Heritage 3Com product" if it is a member of a product family which was manufactured by 3Com prior to its merger with US Robotics Corporation. This Year 2000 limited warranty does not apply to Heritage US Robotics Corporation products. If it appears that any such product does not perform properly with regard to such date data on and after January 1, 2000, and Customer notifies 3Com before the later of April 1, 2000, or ninety (90) days after purchase of the product from 3Com or its authorized reseller, 3Com shall, at its option and expense, provide a software update which would effect the proper performance of such product, repair such product, deliver to Customer an equivalent product to replace such product, or if none of the foregoing is feasible, refund to Customer the purchase price paid for such product.

Any software update or replaced or repaired product will carry a Year 2000 Warranty for ninety (90) days or until April 1, 2000, whichever is later.

OBTAINING WARRANTY SERVICE

Customer must contact 3Com's Corporate Service Center or an Authorized 3Com Service Center within the applicable warranty period to obtain warranty service authorization. Dated proof of purchase may be required. Products returned to 3Com's Corporate Service Center must be pre-authorized by 3Com with a Return Material Authorization (RMA) number marked on the outside of the package, and sent prepaid and packaged appropriately for safe shipment, and it is recommended that they be insured. The repaired or replaced item will be shipped to Customer, at 3Com's expense, not later than thirty (30) days after receipt of the defective product by 3Com.

Dead- or Defective-on-Arrival. In the event a product completely fails to function or exhibits a defect in materials or workmanship within the first forty-eight (48) hours of installation but no later than thirty (30) days after the date of purchase, and this is verified by 3Com, it will be considered dead- or defective-on-arrival (DOA) and a replacement shall be provided by advance replacement. The replacement product will normally be shipped not later than three (3) business days after 3Com's verification of the DOA product, but may be delayed due to export or import procedures. When an advance replacement is provided and Customer fails to return the defective product to 3Com within fifteen (15) days after shipment of the replacement, 3Com will charge Customer for the replacement product, at list price.

3Com shall not be responsible for any software, firmware, information, or memory data of Customer contained in, stored on, or integrated with any products returned to 3Com for repair, whether under warranty or not.

WARRANTIES EXCLUSIVE

IF A 3COM PRODUCT DOES NOT OPERATE AS WARRANTED ABOVE, CUSTOMER'S SOLE REMEDY FOR BREACH OF THAT WARRANTY SHALL BE REPAIR, REPLACEMENT, OR REFUND OF THE PURCHASE PRICE PAID, AT 3COM'S OPTION. TO THE FULL EXTENT ALLOWED BY LAW, THE FOREGOING WARRANTIES AND REMEDIES ARE EXCLUSIVE AND ARE IN LIEU OF ALL OTHER WARRANTIES, TERMS, OR CONDITIONS, EXPRESS OR IMPLIED, EITHER IN FACT OR BY OPERATION OF LAW, STATUTORY OR OTHERWISE, INCLUDING WARRANTIES, TERMS, OR CONDITIONS OF MERCHANTABILITY, FITNESS FOR A PARTICULAR PURPOSE, AND SATISFACTORY QUALITY. 3COM NEITHER ASSUMES NOR AUTHORIZES ANY OTHER PERSON TO ASSUME FOR IT ANY OTHER LIABILITY IN CONNECTION WITH THE SALE, INSTALLATION, MAINTENANCE OR USE OF ITS PRODUCTS.

3COM SHALL NOT BE LIABLE UNDER THIS WARRANTY IF ITS TESTING AND EXAMINATION DISCLOSE THAT THE ALLEGED DEFECT IN THE PRODUCT DOES NOT EXIST OR WAS CAUSED BY CUSTOMER'S OR ANY THIRD PERSON'S MISUSE, NEGLIGENCE, IMPROPER INSTALLATION OR TESTING, UNAUTHORIZED ATTEMPTS TO REPAIR OR MODIFY, OR ANY OTHER CAUSE BEYOND THE RANGE OF THE INTENDED USE, OR BY ACCIDENT, FIRE, LIGHTNING, OR OTHER HAZARD.

LIMITATION OF LIABILITY

TO THE FULL EXTENT ALLOWED BY LAW, 3COM ALSO EXCLUDES FOR ITSELF AND ITS SUPPLIERS ANY LIABILITY, WHETHER BASED IN CONTRACT OR TORT (INCLUDING NEGLIGENCE), FOR INCIDENTAL, CONSEQUENTIAL, INDIRECT, SPECIAL, OR PUNITIVE DAMAGES OF ANY KIND, OR FOR LOSS OF REVENUE OR PROFITS, LOSS OF BUSINESS, LOSS OF INFORMATION OR DATA, OR OTHER FINANCIAL LOSS ARISING OUT OF OR IN CONNECTION WITH THE SALE, INSTALLATION, MAINTENANCE,

USE, PERFORMANCE, FAILURE, OR INTERRUPTION OF ITS PRODUCTS, EVEN IF 3COM OR ITS AUTHORIZED RESELLER HAS BEEN ADVISED OF THE POSSIBILITY OF SUCH DAMAGES, AND LIMITS ITS LIABILITY TO REPAIR, REPLACEMENT, OR REFUND OF THE PURCHASE PRICE PAID, AT 3COM'S OPTION. THIS DISCLAIMER OF LIABILITY FOR DAMAGES WILL NOT BE AFFECTED IF ANY REMEDY PROVIDED HEREIN SHALL FAIL OF ITS ESSENTIAL PURPOSE.

DISCLAIMER

Some countries, states, or provinces do not allow the exclusion or limitation of implied warranties or the limitation of incidental or consequential damages for certain products supplied to consumers or the limitation of liability for personal injury, so the above limitations and exclusions may be limited in their application to you. When the implied warranties are not allowed to be excluded in their entirety, they will be limited to the duration of the applicable written warranty. This warranty gives you specific legal rights which may vary depending on local law.

GOVERNING LAW

This Limited Warranty shall be governed by the laws of the State of California, U.S.A. excluding its conflicts of laws principles and excluding the United Nations Convention on Contracts for the International Sale of Goods.

3Com Corporation, 5400 Bayfront Plaza, Santa Clara, CA 95052-8145 (408) 764-5000